



TECHNICAL HANDBOOK

MT System

Eurocode 3 (EN 1993)

Terms of common cooperation / Legal disclaimer

The product loading capacities published in these Technical Data Sheets are only valid for the mentioned codes or Technical Data generation methods and the defined application conditions (e.g. ambient temperature load capacity not valid in case of fire, data not valid in support structures when mixed with third party products), assuming sufficient fastener, Base Material and building structure strength. Additional calculations, checks and releases by the responsible structural engineer are needed to clarify the capacity of base material and building structure. Suitability of structures combining different products for specific Applications needs to be verified by conducting a system design and calculation, using for example Hilti PROFIS software.

In addition, it is crucial to fully respect the Instructions for Use and to assure clean, unaltered and undamaged state of all products at any time in order to achieve this loading capacity (e.g. misuse, modification, overload, corrosion). As products but also Technical Data generation methodologies evolve over time, Technical Data might change at any time without prior notice. We recommend to use the latest Technical Data sheets published by Hilti.

In any case the suitability of structures combining different products for specific Applications need to be checked and cleared by an expert, particularly with regard to compliance with applicable norms and permits, prior to using them for any specific facility. This book only serves as an aid to interpret the suitability of structures combining different products for specific Applications without any guarantee as to the absence of errors, the correctness and the relevance of the results or suitability for a specific application. User must take all necessary and reasonable steps to prevent or limit damage. The suitability of structures combining different products for specific Applications are only recommendations that need to be confirmed with a professional designer and/or structural engineers to ensure compliance with User's specific jurisdiction and project requirements.

Contents

0. Technical notes	10
1. MT System	14
1.1 MT Open C-Channel Fixation	14
1.2 MT Box Profile Fixation	19
2. MT Profiles	25
2.1 MT Trapeze Profiles	25
2.2 MT Open C-Channels (single)	28
2.3 MT Open C-Channels (double)	32
2.4 MT Box Profiles	36
2.5 MT Profiles Technical Data	40
3. MT Brackets	73
3.1 MT Brackets	73
4. MT Connectors	78
4.1 MT Open C-Channel Connectors	78
4.2 MT Open C-Channel Fast-Lock Connectors	117
4.3 MT Box Profiles Connectors	131
5. MT Base Material Connectors	163
5.1 MT Open C-Channel Base Material Connectors	163
5.2 MT Box Profiles Base Material Connectors	182
6. MT Media Fixation	202
6.1 MT Media Fixation for Open C-Channels	202
6.2 MT Media Fixation for Box Profiles	216
7. MT Miscellaneous	230
7.1 MT Beam Clamps	230
7.2 MT Profile End Caps	232
7.3 MT Profile Rubber Inlays	236
8. MT Roof Top Application portfolio	238
9. MT Seismic Bracing portfolio	244
10. MT Elevator Divider Beam portfolio	267

One system, countless scenarios

Easier to design and assemble than ever, Hilti's MT System is a flexible, modular solution for virtually all your installation support structures.

Do more with less

From light utilities like air ducts, communication cables and cable trays to larger non-critical piping, heavier cable ladders and mechanical equipment, Hilti's MT System handles most loading scenarios while enabling highly efficient installations.

This allows you to streamline the planning, managing and assembly of your metal framing and support structures. For example, you can

seamlessly combine all MEP utilities into a single structure designed for optimal efficiency.

The MT System's cross-compatibility and interchangeability help enable value-engineered solutions that optimize costs and improve sustainability. The components and baseplates complement the range of profiles, so you can complete your installation with one system.

Design with ease

The MT System's large portfolio of trapeze profiles, C-Channels and box profiles make it easier to design even complex multi-trade support installations. The system also features direct box-profile-on-box-profile connectivity as well as direct fixation of Trapeze and C-Channel profiles to box profiles. Additionally, some connectors are compatible with both C-Channels and box profiles.



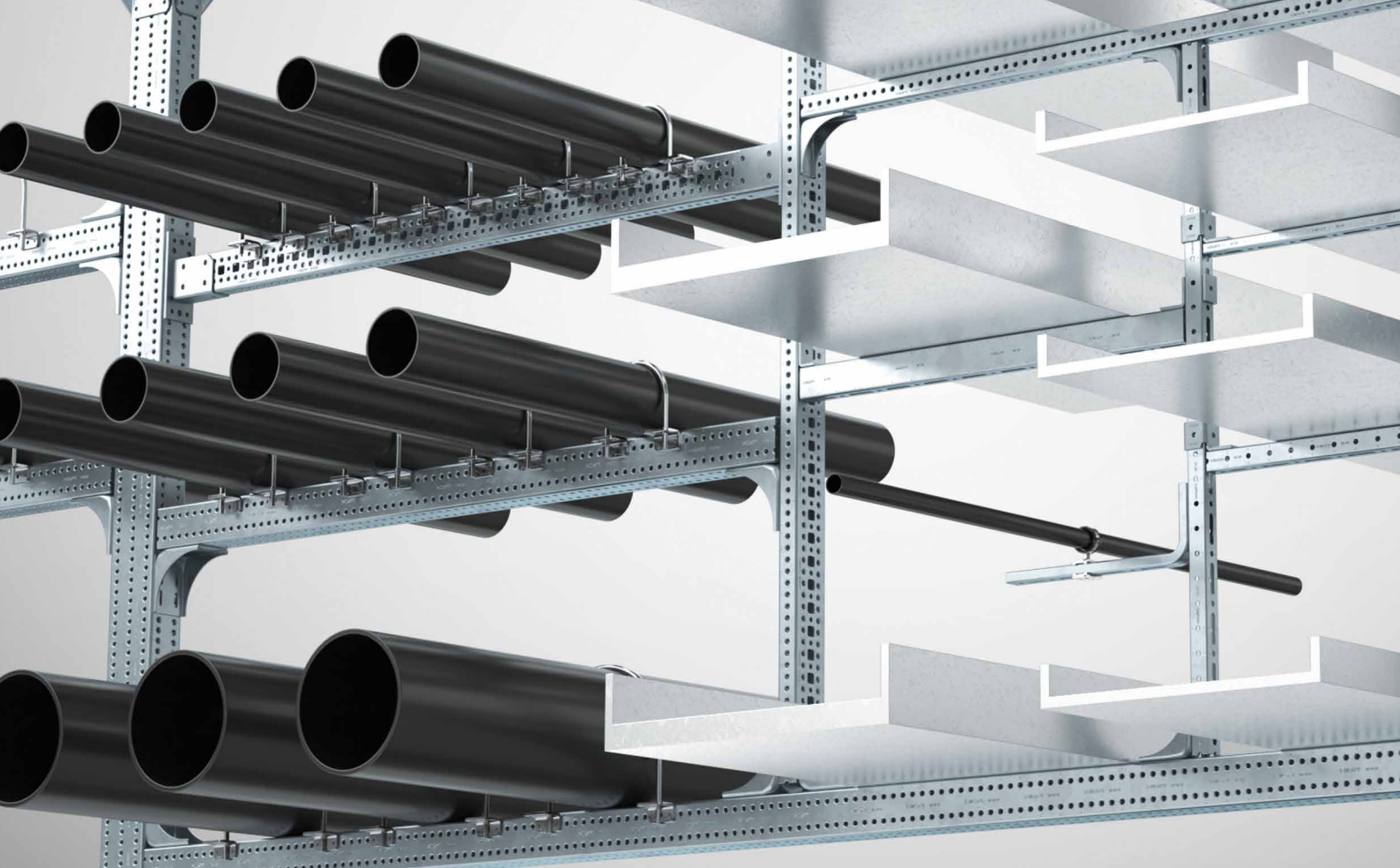

Embrace simplicity

The MT System features intuitive, robust bolting mechanisms for box profiles to help minimize installation errors: The Thread Forming Bolt (MT-TFB) is the go-to bolt for all domed hole connections, so you'll always have the right bolt for a given fixation combination.

More productive

Releasing, repositioning and subsequent retorquing of TFB fixations is enabled, allowing the modular system to remain flexible.

More intuitive

A purposely lean portfolio, designed to minimize overall number of components, leads to a reduced variety of connectors, helping minimize the complexity and cost of stock management, and limits delays on site from missing items. Fixation of elements to box profiles domed holes can be accomplished with just one version of a simple bolt (MT-TFB).

More Secure

The Hilti SIW-AT impact wrench with Adaptive Torque system helps you set bolts to the recommended tightness more quickly and consistently.

Hilti's MT-TFB Thread Forming Bolts securely connect to box profile without the need for nuts or washers. During installation, a robust thread is formed within the box profile dome, reducing the risk of thread stripping.

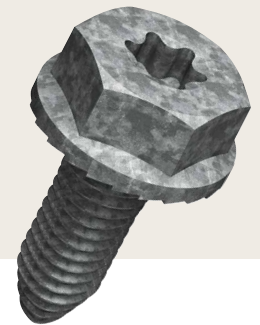



Your partner for productivity

Attach, Adjust, Re-adjust

With the new hybrid profile MT-90H, media connections are faster and simpler than ever before. Complex 3D structures requiring a high degree of adjustability can be mastered more easily.

Value engineered

Space-saving designs can be created to accommodate installations in tight spaces while allowing easy access for maintenance. The MT System offers full flexibility and adjustability with few parts and assembly steps needed.

Higher performing

No additional C-Channels need to be mounted on top of the box profile, which helps reduce weight and CO₂ while speeding up mounting time to decrease the total cost of installation.

More peace of mind

The MT System covers a wide range of codes and approvals. Our Global Project Management support can assist you in realizing your project from planning to execution, while helping you meet your time, cost and sustainability objectives.

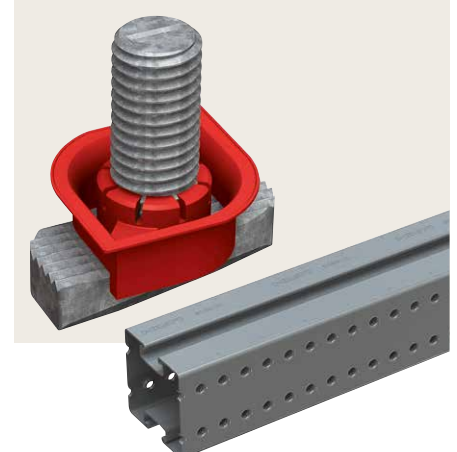

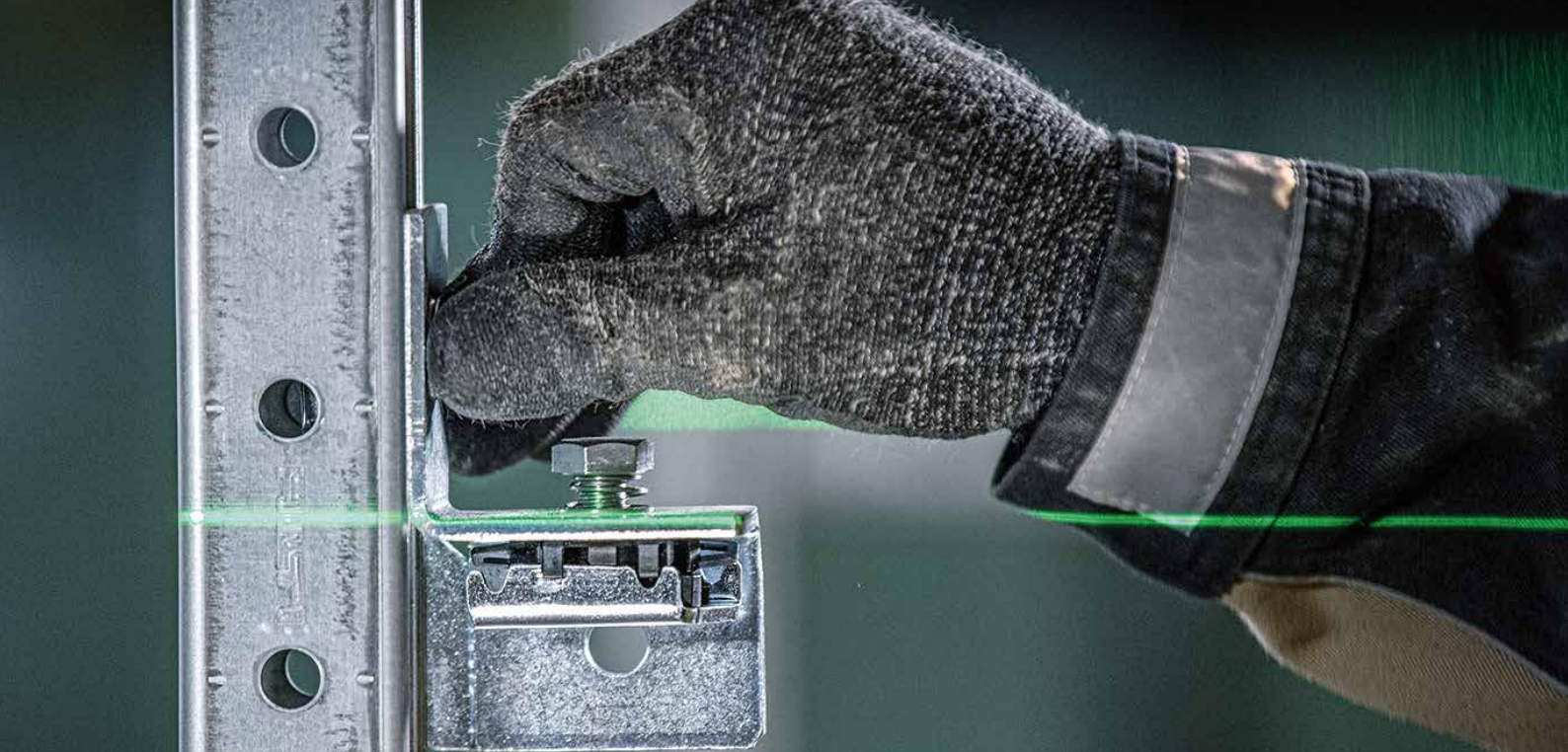

Faster, Simpler, Safer

The MT System offers a comprehensive range of preassembled connectors and baseplates to help speed up installation of your MEP supports.

Faster

By eliminating non-value-adding steps from the assembly process, you can achieve up to 50% time savings compared to basic connection solutions.

Simpler

With fewer single parts and boxes to handle on the jobsite, your purchasing and stock management processes become easier.

Safer

The MT System is compatible with our Adaptive Torque (AT) module, enabling consistent torquing, while pre-assembled parts reduce the likelihood of installation mistakes.

Fast-Lock innovation

The preassembled connectors feature an innovative connection mechanism that enhances installation flexibility.

Simple and easy to use, it provides a reliable connection on MT C-Channels and can be easily disassembled, adjusted and repositioned even after initial full torque.

The Fast-Lock and the pre-assembled portfolios are available in both Indoor Coated (black) and Outdoor Coated (red) versions.

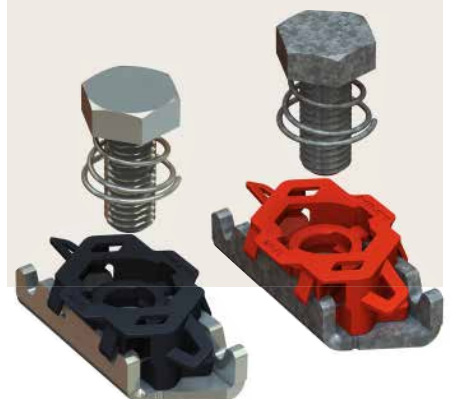
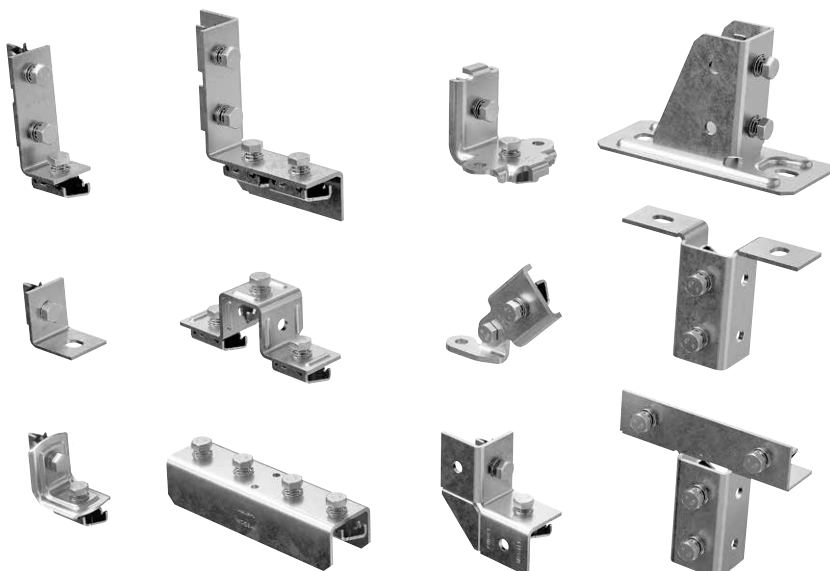

Designed to perform

Discover the flexibility of our latest innovation in C-Channel connectivity: The MT System is designed to adapt to your needs seamlessly.

Serration on the spot

Hilti MT-TL Twist-Lock channel nuts create their own serration during torquing, making it one of the first seamless C-Channel fixation methods with shear capacity.

Universal

Serration is created on the spot, thus eliminating the need for preformed serrations in the channel. Known restrictions of positioning steps (typically 2 mm) due to serrations become obsolete.

Adjustable

Releasing, repositioning, and subsequent retorquing of elements fixed with MT-TL remains fully enabled.

Reliable

Mechanical connection of the MT-TL is realized without reliance on friction, thus providing the required shear capacity for C-Channel connections.

Fast and easy

During installation, connection elements can be intuitively positioned and locked in place.

Twist-Lock innovation

Hilti MT-TL channel nuts can be installed with a one-handed “twist and lock” into position. A groove is cut into the channel, allowing for rapid and accurate placement of components. During installation, Twist-Locks do not slip before final torquing.

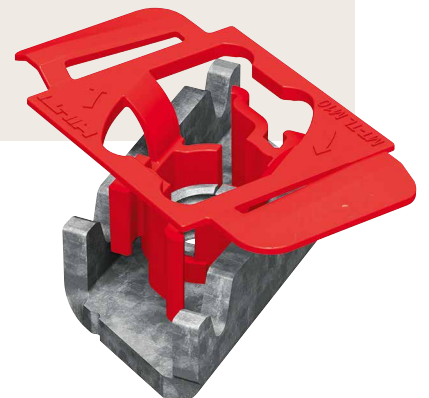

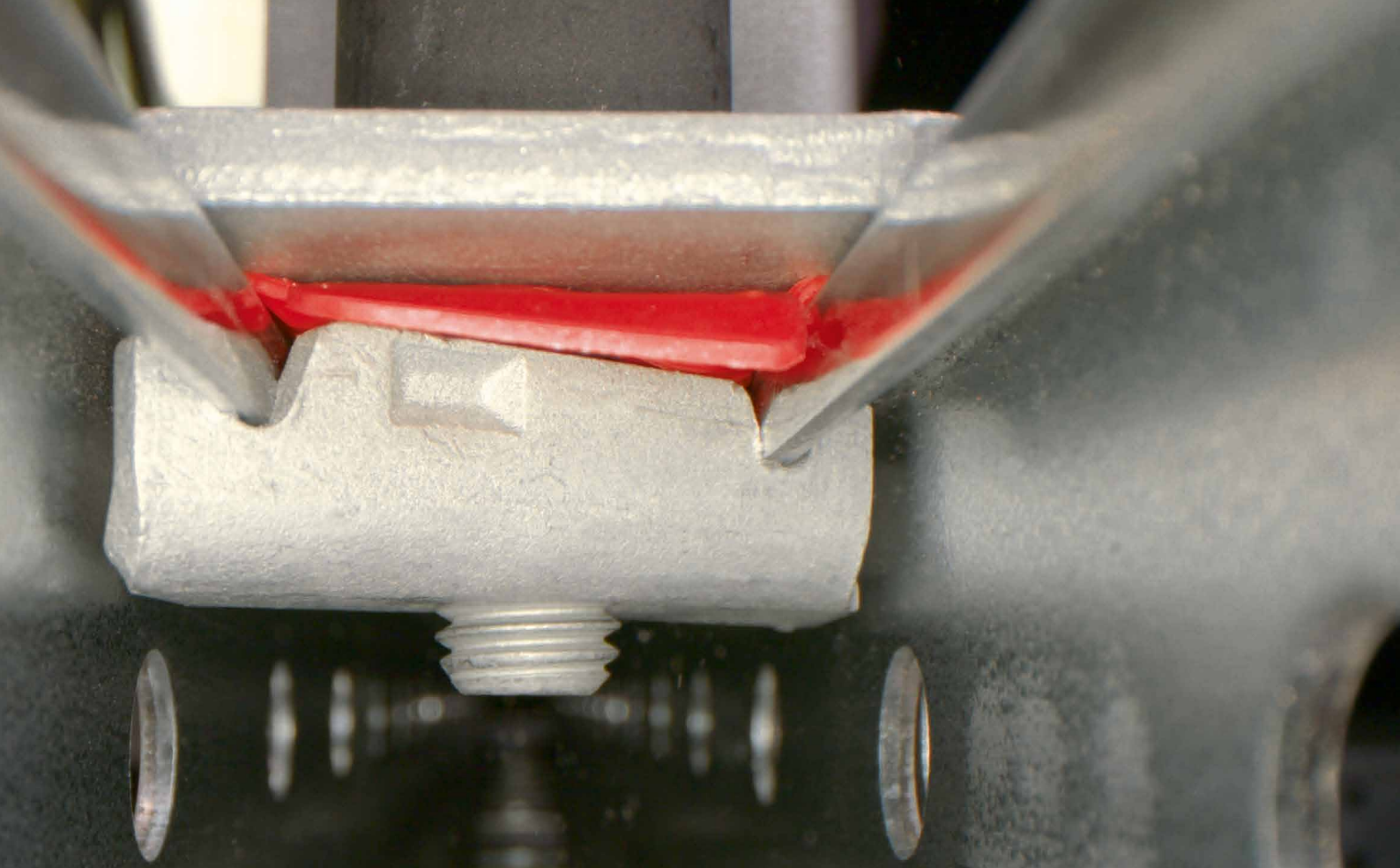

Advanced corrosion protection

The MT System is designed to last in both indoor and low-to-moderate outdoor pollution conditions thanks to advanced corrosion protection technologies.

Performs under most conditions

For indoor usage, Hilti's established high-quality protection is used: Profiles are Sendzimir galvanized, connectors and baseplates are zinc electroplated.

Solutions designed for outdoor use combine hot-dip galvanization for components (such as connectors and baseplates) and zinc-magnesium galvanization (ZM technology) for profiles. ZM profiles conform to the ASTM A1046 and EN 10346 standards.

The outdoor solutions result in durability levels (as defined by ISO 12944:2017) in C3 environment of 25 years (VH, very high) and in C4 environment of 15 years (H, high).

Breakthrough coating technology

The Zinc Magnesium (ZM) corrosion protection combines robustness and longevity with increased environmental sustainability and cost optimization.

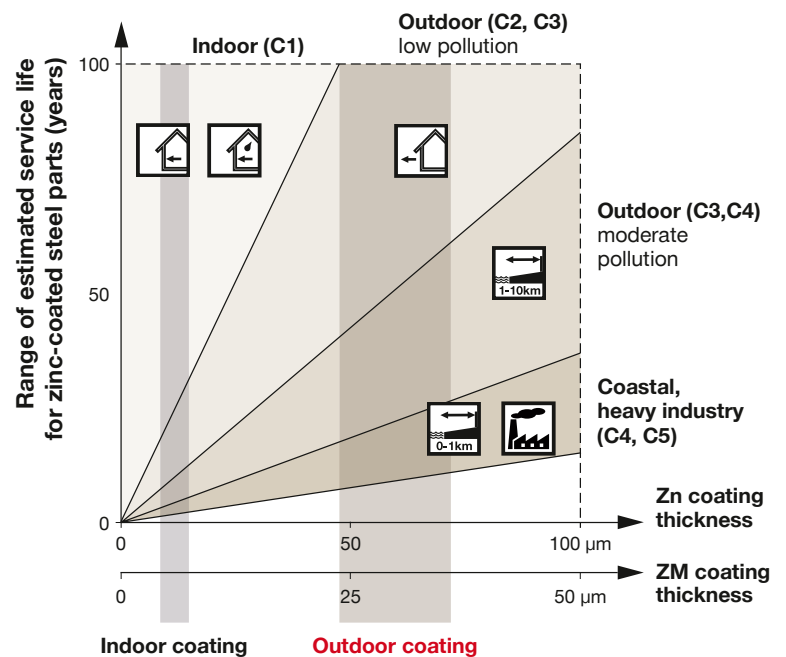

0. Technical notes

Evaluations of Technical Data

Technical Data herein is based on analytical calculations, finite element analysis or laboratory testing based on the provisions of Eurocodes EN 1990 and EN 1993.

Analytical Calculations

Analytical calculations for the design of joints as per EN 1993-1-8 are considered for the Connector Base Material as well as bolted and welded connections.

Finite Element Analysis

In line with EN 1993-1-5, finite element analysis is an established alternative method for obtaining resistance data. Such analyses with shell and/or solid finite element models are performed to derive Technical Data for Connector components contained herein. State-of-the-art software and modelling technics considering geometrical and material non-linearities as per EN 1993-1-5 are applied. The final resistance data herein considers the serviceability limit state (deformation) as well as the ultimate limit state (stress/strain and stability).

Testing

Structural performance via testing and evaluation is required when the strength of an element, connection, or assembly cannot be determined per the provisions of the Eurocode EN 1993. Moreover, they are performed to calibrate and validate finite element analysis and typically set the basis for Connector load data in the most application relevant load directions. The assessment of laboratory tests is following the boundary conditions and statistical rules of EN 1990 Annex D.

Safety concept

On design and recommended resistance

- The design resistance of the products (X_d) in this document is defined in accordance with EN1993
 - EN1993 partial safety factors for resistance (γ_M) are included
 - Deformation limit is considered when defining the resistance

- All the resistances stated in this document are recommended values (X_r)**

- Recommended values are always calculated from the design load via a Hilti concept safety factor (γ_{Hilti})

$$X_r = \frac{X_d}{\gamma_{Hilti}}$$

- γ_{Hilti} includes the action partial safety factors, as per EN1990. This is a HILTI concept
 - The value of γ_{Hilti} can vary from one part to another. It can be 1.4 or 1.5.
- From the chart below it is noted that the comparison of "Recommended resistance" shall always be made with „Unfactored load“, and "Design resistance" with "Design load"

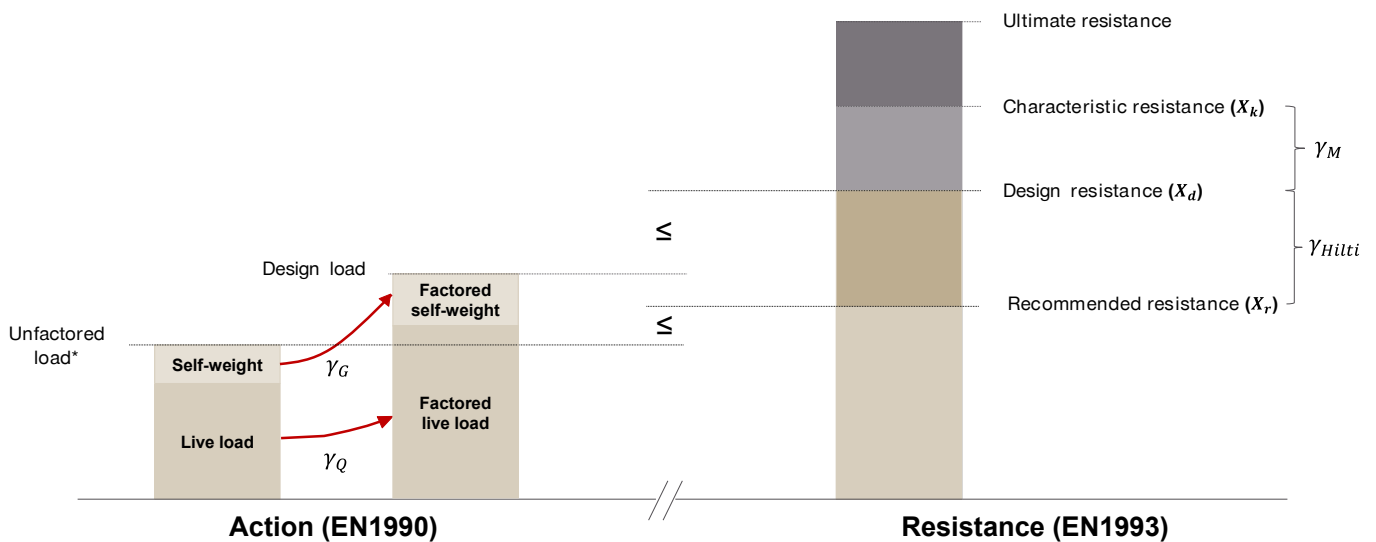

* It is noted that in EN1990 this is defined as «Characteristic load», i.e., the main representative value of a load. To enable an easier understanding of Hilti's safety concept, it is renamed to «Unfactored load» to highlight that it means weight of applied load without partial safety factors applied on top.

General information on corrosion protection

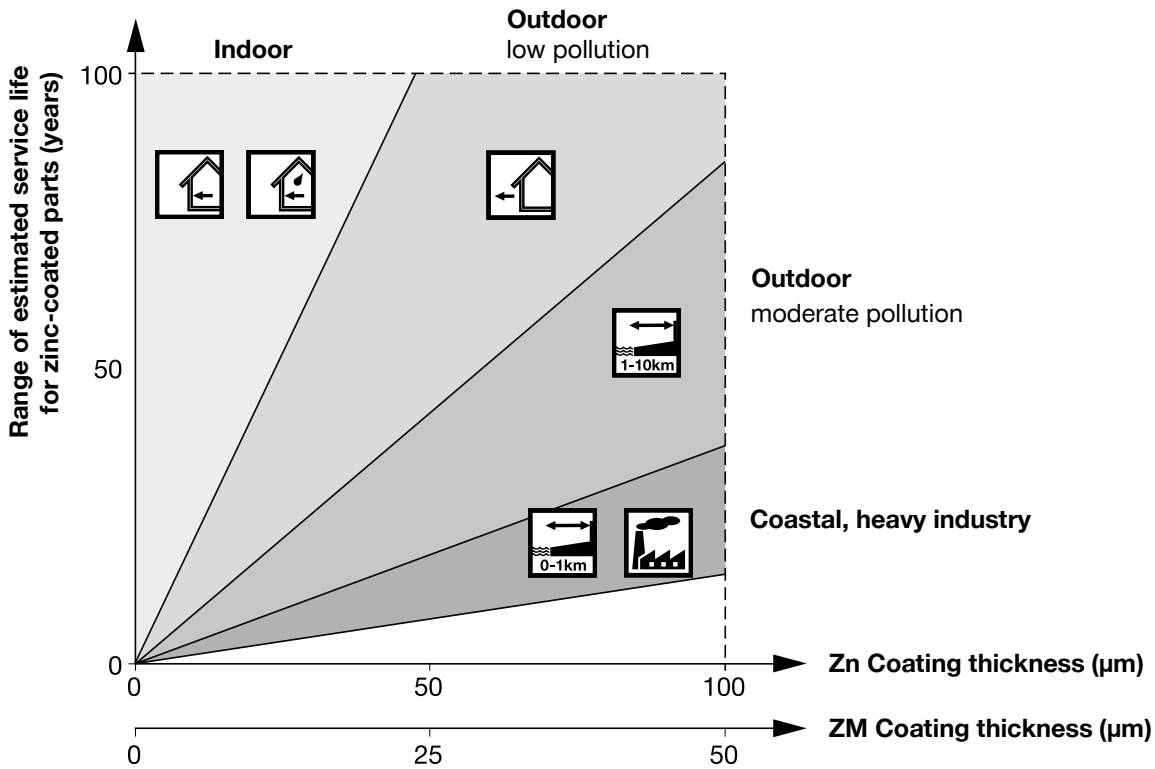

HILTI CORROSION RESISTANCE			
Hilti Corrosion Resistance	INDOOR COATED	OUTDOOR COATED	OUTDOOR PLUS
Corrosion class/ min. lifetime	C1 > 50 years C2 > 20 years	C3 > 25 years C4 > 15 years	C5 > 15 years (ask expert)
Corrosion environment	low-moderate	moderate-high	high-extreme

Hilti's installation systems are supplied in various coating technologies to meet the requirements under almost all conditions:

Hilti System	Indoor coated		Outdoor coated		Outdoor Plus	
	Zn	HDG Zn	HDG ZM	S A2	S A4	
MT-Profiles	X		X			
MT-Components	X	X				

The typical lifetime expectancy of Hilti's installation systems is shown in the table below:

Installation systems	Indoor coated		Outdoor coated		Outdoor Plus	
	channel system	MT, MQ, MM, MC	MT-OC, MQ-F, MQ ASTM, MC-OC, MI, MIQ		MQ system stainless A2/ AISI 304	MQ system stainless A4/ AISI 316
	Pipe fastening	Indoor pipe clamps ¹	Outdoor pipe clamps ²	MP-UB OC, MP-US OC, MP-PS	Outdoor Plus pipe clamps ³	
Environmental conditions		lifetime (in years)				
	Dry indoor	50-100	100		■	■
	Indoor with temporary condensation	25-70	50-100		■	■
	Outdoor with low pollution	5-10	25-70		■	■
	Outdoor with moderate concentration of pollutants	-	15-40		■	■
	Coastal areas	-	5-20		-	■
	Outdoor, areas with heavy industrial pollution	-	5-20		-	■
	Close proximity to roads	-	-		-	■
	Special Applications	Consult experts				

■ = expected lifetime of an installation system made from this material is typically satisfactory in the specified environment based on the typically expected lifetime of a building.

- ¹ Indoor pipe clamps: MP-L-I, MP-H, MP-HI, MP-P, MP-PI MP-U, MP-U-I, MP-U-G, MP-M, MP-MI, MP-MIS, MP-MX, MP-MXI, MRP-C, MIP, MRP-KF, MP-KF 170, MI-CF, MP-MS, MP-SPN, LH, SDC, MV-P, MV-PI, MV-PIF, MP-UB
- ² Outdoor pipe clamps: MP-PI-HDG, MP-M-F, MP-MI-F, MP-MX-F, MP-MX-F
- ³ Outdoor PLUS pipe clamps: MP-SRN, MP-SRNI, MPN-R, MP-MR, MP-MRI, MP-MRXI

1. MT System

1

MT-FL Fast-Lock Channel nut with bolt

Fast-Lock Channel nut with bolt for attaching baseplates and Connectors to MT C-Channels

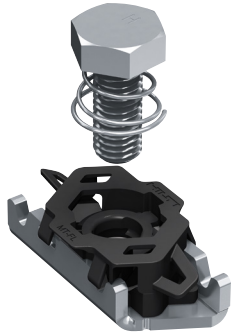

Applications

- Connecting all compatible hardware to MT C-Channels
- Connection element for U-frame/crossbeam structures
- Assembling MEP support structures using MT C-Channels
- Suitable for use in dry, indoor environments

Order Designation	Technical data	Sales pack quantity	Item number
MT-FL	Dry indoor conditions (C1) Indoor with temporary condensation (C2)	50 pc	2399683

Advantages

- Faster connections and adjustments – one-handed push-and-turn connections and one-click position adjustments allow you to assemble modular support systems much faster than standard spring nuts
- Simple to adjust – Fast-Lock nuts are re-adjustable and can be easily disassembled so you can modify C-Channel framing during installation
- Safety features – designed so you can see, hear, and feel correct Channel nut positioning, with pre-holding function to hold Connector in place as soon as the mechanism is activated
- Reliable connections – strong mechanical Fixation to the Channel flanges provides high shear and pull-out resistance
- Part of the Hilti MT system – an economical, all-in-one solution for virtually all modular MEP support structures
- Extensive software support - PROFIS Modular Support Engineering, BIMCAD content, and Revit® families are all available to streamline design and ordering
- Compatible with the Hilti Adaptive Torque system – use a cordless impact wrench to quickly tighten nuts to the correct pretension (compatible tool and SI-AT module required)

MT-FL OC Fast-Lock Channel nut with bolt

Fast-Lock Channel nut with bolt for attaching baseplates and Connectors to MT C-Channels, for outdoor use with low pollution

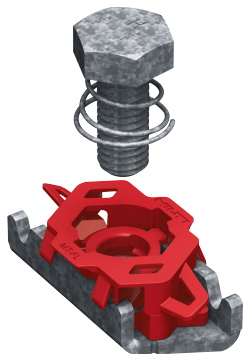

Applications

- Connecting all compatible hardware to MT C-Channels
- Connection element for U-frame/crossbeam structures
- Assembling MEP support structures using MT C-Channels
- Suitable for use in moderately corrosive environments

Order Designation	Technical data	Sales pack quantity	Item number
MT-FL OC	Outdoor, low to moderate pollution (C3 / C4 - low)	50 pc	2399682

Advantages

- Faster connections and adjustments – one-handed push-and-turn connections and one-click position adjustments allow you to assemble modular support systems much faster than standard spring nuts
- Simple to adjust – Fast-Lock nuts are re-adjustable and can be easily disassembled so you can modify C-Channel framing during installation
- Safety features – designed so you can see, hear, and feel correct Channel nut positioning, with pre-holding function to hold Connector in place as soon as the mechanism is activated
- Reliable connections – strong mechanical Fixation to the Channel flanges provides high shear and pull-out resistance
- Part of the Hilti MT system – an economical, all-in-one solution for virtually all modular MEP support structures
- Extensive software support - PROFIS Modular Support Engineering, BIMCAD content, and Revit® families are all available to streamline design and ordering
- Compatible with the Hilti Adaptive Torque system – use a cordless impact wrench to quickly tighten nuts to the correct pretension (compatible tool and SI-AT module required)

MT-TL Twist-Lock Channel Nut

Nut for attaching Media to MT Open C-Channels



1

Applications

- Connecting all compatible hardware to MT C-Channels
- Assembling shear-resistant metal framing for MEP support structures using MT C-Channels (M10 version only)
- Suitable for use in dry, indoor environments

Advantages

- Part of the Hilti MT system – an economical, all-in-one solution for virtually all modular MEP support structures
- High shear and pull-out resistance provided by a reliable mechanical Fixation to the Channel flanges
- Easy to install – insert into C-Channel using a one-handed “push-and-twist” motion
- Adaptable – unlike welding, Twist-Locks allow you to modify C-Channel framing during installation and for future MEP requirements
- Compatible with MT System C-Channels – no need for serrations on the Channel flanges
- Compatible with the Hilti Adaptive Torque system – use a cordless impact wrench to quickly tighten nuts to the correct pretension (compatible tool and SI-AT module required)

MT-TL Twist-Lock Channel Nut

M6 / M8 / M10 / M12 / M16 / 1/2 / 3/8

Order Designation	Technical data	Sales pack quantity	Item number
MT-TL 1/4	Dry indoor conditions (C1) Indoor with temporary condensation (C2)	50 pc	2388023
MT-TL M6		50 pc	2343283
MT-TL M8		30 pc	2273630
MT-TL M10		30 pc	2272080
MT-TL M12		30 pc	2273632
MT-TL M16		30 pc	2273634
MT-TL 1/2		30 pc	2273638
MT-TL 3/8		50 pc	2273636
MT-TL 5/8		30 pc	2388025

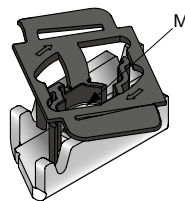

MT-TL OC Twist-Lock Channel Nut

Nut for attaching Media to Open C-Channel - outdoor

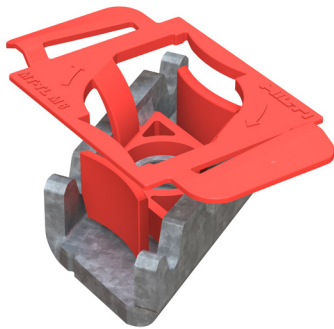

Applications

- Connecting all compatible hardware to MT C-Channels
- Assembling shear-resistant metal framing for MEP support structures using MT C-Channels (M10 version only)
- Suitable for use in moderately corrosive environments

Advantages

- Part of the Hilti MT system – an economical, all-in-one solution for virtually all modular MEP support structures
- High shear and pull-out resistance provided by a reliable mechanical Fixation to the Channel flanges
- Easy to install – insert into C-Channel using a one-handed “push-and-twist” motion
- Adaptable – unlike welding, Twist-Locks allow you to modify C-Channel framing during installation and for future MEP requirements
- Compatible with MT System C-Channels – no need for serrations on the Channel flanges
- Compatible with the Hilti Adaptive Torque system – use a cordless impact wrench to quickly tighten nuts to the correct pretension (compatible tool and SI-AT module required)

MT-TL Twist-Lock Channel Nut - Outdoor M6 / M8 / M10 / M12 / M16 / 1/2 / 3/8 OC

Order Designation	Technical data	Sales pack quantity	Item number
MT-TL 1/4 OC	Outdoor, low to moderate pollution (C3 / C4 - low)	50 pc	2388024
MT-TL M6 OC		50 pc	2343284
MT-TL M8 OC		30 pc	2273631
MT-TL M10 OC		30 pc	2272082
MT-TL M12 OC		30 pc	2273633
MT-TL M16 OC		30 pc	2273635
MT-TL 1/2 OC		30 pc	2273639
MT-TL 3/8 OC		50 pc	2273637
MT-TL 5/8 OC		30 pc	2388026

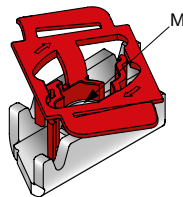

MT-TLB Twist-Lock Bolt

Hexagon-head bolt for use with Twist-Locks when assembling Open C-Channel structures

1

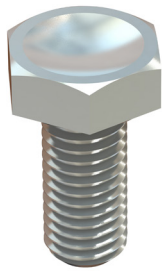

Applications

- Connecting all compatible hardware to MT C-Channel
- Assembling shear-resistant metal framing for MEP support structures using MT C-Channels
- Suitable for use in dry, indoor environments

Advantages

- Easy to install – compatible with the Hilti MT Twist-Lock, a faster alternative to spring nuts for assembling a modular support system
- Compatible with the Hilti Adaptive Torque system – use a cordless impact wrench to quickly tighten bolts to the correct pretension (compatible tool and SI-AT module required)

Technical data

Material composition	ISO 898-1 8.8
Surface finish	Indoor Coated - Electro Galvanized

MT-TLB Twist-Lock Bolt

Order Designation	Technical data	Sales pack quantity	Item number	
MT-TLB	Dry indoor conditions (C1) Indoor with temporary condensation (C2)	200 pc	2273254	
MT-TLB 30		200 pc	2282190	

MT-TLB OC Twist-Lock Bolt - Outdoor

Hexagon bolt for use with Twist-Locks when assembling Open C-Channel structures for outdoor use with low pollution

1



Applications

- Connecting all compatible hardware to MT C-Channel
- Assembling shear-resistant metal framing for MEP support structures using MT C-Channels
- Suitable for use in moderately corrosive environments

Advantages

- Easy to install – compatible with the Hilti MT Twist-Lock, a faster alternative to spring nuts for assembling a modular support system
- Compatible with the Hilti Adaptive Torque system – use a cordless impact wrench to quickly tighten bolts to the correct pretension (compatible tool and SI-AT module required)

Technical data

Material composition	ISO 898-1 8.8
Surface finish	Multi-layer coating, designed for corrosion environment category C3 according ISO 9223

MT-TLB OC Twist-Lock Bolt - Outdoor

Order Designation	Technical data	Sales pack quantity	Item number	
MT-TLB OC	Outdoor, low to moderate pollution (C3 / C4 - low)	200 pc	2273256	
MT-TLB 30 OC		200 pc	2282191	

MT-TFB OC Thread forming Bolt

Thread-forming bolt for use when assembling MT Box Profile structures

1



Applications

- Connecting all compatible hardware to MT Box Profiles
- Assembling metal framing for MEP support structures by fixing compatible MT Connectors
- Direct attachment of MT Profiles and channels to MT Box Profiles, or any MT Box Profile to MT-80

Advantages

- Part of the Hilti MT system – an economical, all-in-one solution for virtually all modular MEP support structures
- One-step installation – no nut required
- Compatible with the Hilti Adaptive Torque system – use a cordless impact wrench to quickly tighten bolts to the correct pretension (compatible tool and SI-AT module required)
- Versatile – suitable for all MT girders and connection hardware

Technical Data

Material composition	High Strength Steel
Surface finish	Outdoor Coated - Multilayer

MT-TFB OC Thread forming Bolt - Outdoor

Order Designation	Technical Data	Sales pack quantity	Item number	
MT-TFB OC	Outdoor, low to moderate pollution (C3 / C4 - low)	250 pc	2272084	

MT-THB OC Connection Mechanisms

T-head bolt for fastening Connectors and other construction elements into the mounting slot of MT Seamless Box Profiles in moderately corrosive environments

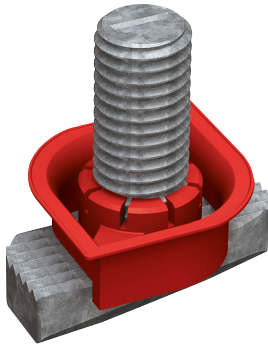

Applications

- Simple but secure bolt for fastening Connectors and other construction elements to MT Profiles
- Optional M12x33 version for overhead grid Applications
- Multidisciplinary MEP support structures combining a wide range of Media such as air ducts, cable trays, piping, etc.
- Ceiling-mounted MEP support structures with heavy loads such as ceiling grids and utility piping and drainage
- Integrated modules and skids to support industrial pipes and other heavy-duty building services

Advantages

- Simple to adjust – can be inserted and adjusted at any point along the Profile, with 2.5 mm (1/8") incremental adjustments
- Faster to install – switch between MT Thread forming Bolts (MT-TFB) and MT T-head bolts (MT-THB) without interruption, thanks to matching socket size and AT-Module torque parameters
- Reduced complexity – designed as a single piece and in one standard size for all structural connections, for easier purchasing, handling, and storage
- Reliable connections – compatible with the Hilti Adaptive Torque system for tightening bolts to the correct pretension (compatible tool and SI-AT module required)

Technical Data

Material composition	High Strength Steel
Surface finish	Outdoor Coated - Multilayer

MT-THB OC Connection Mechanism

Order Designation	Technical Data	Length - L	Sales pack quantity	Item number	
MT-THB OC	Outdoor, low to moderate pollution (C3 / C4 - low)	22 mm	20 pcs	2431080	
MT-THB M12x33 OC		33 mm	20 pcs	2431092	

Operation Instruction
 MT-FL / MT-FL OC

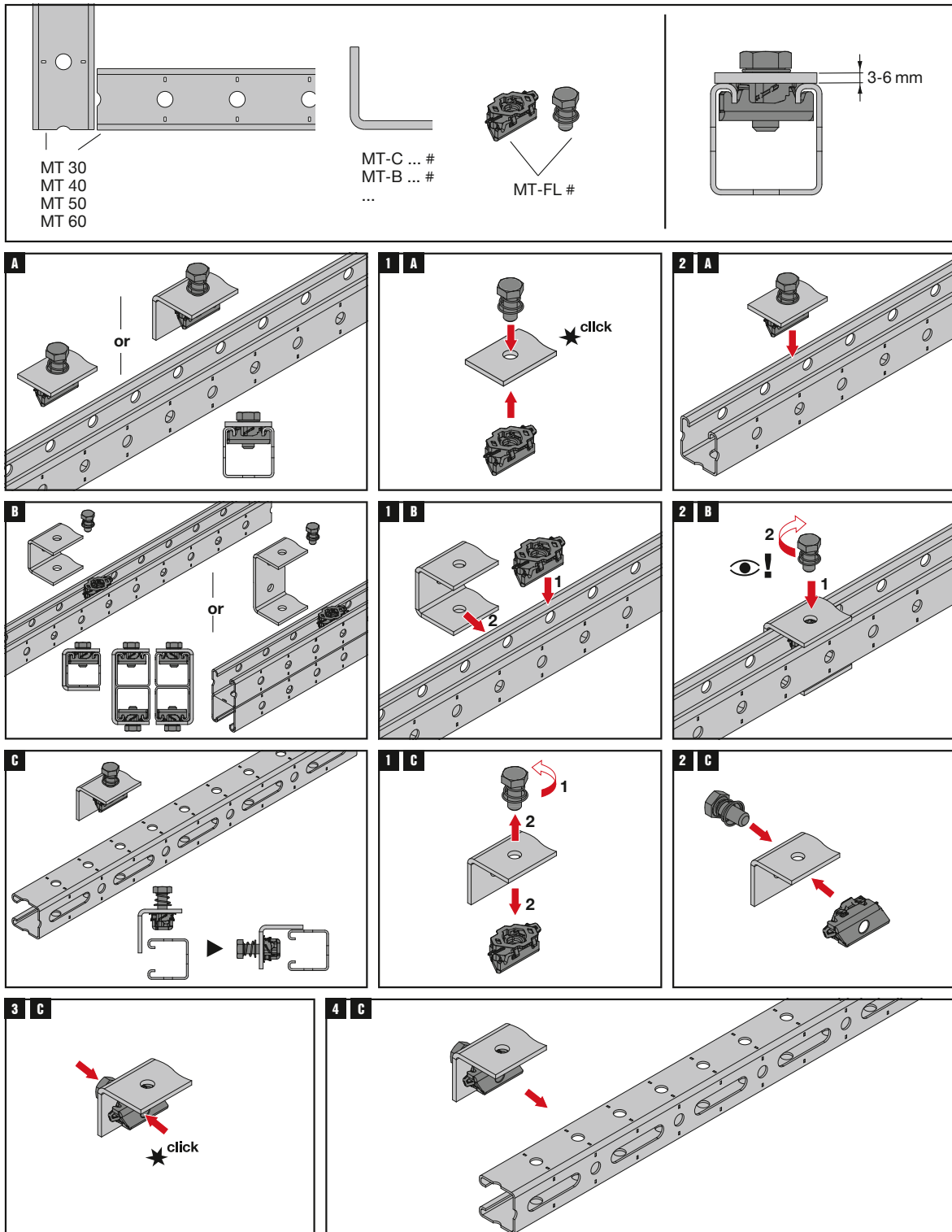
1

The latest IFU (Instruction for Use) is available on Hilti Online. Please check for any revisions before installing the product.

MT-TL Twist-Lock channel Nut

1

Operation instruction

MT-TL M6 / MT-TL 1/4" / MT-TL M6 OC / MT-TL 1/4" OC

		8.8
MT-TL M6 MT-TL M6 OC	7 Nm	
MT-TL 1/4" MT-TL 1/4" OC		

The latest IFU (Instruction for Use) is available on Hilti Online. Please check for any revisions before installing the product.

Operation instruction

MT-TL M8 / MT-TL M8 OC / MT-TL 3/8" / MT-TL 3/8" OC / MT-TL M10 / MT-TL M10 OC

	SW 8.8	
MT-TL M8	30 Nm	10 Nm
MT-TL M8 OC		
MT-TL 3/8"	40 Nm	20 Nm
MT-TL 3/8" OC	(30 ft-lb)	(15 ft-lb)
MT-TL M10	30 Nm	15 Nm
MT-TL M10 OC	40 Nm	25 Nm

The latest IFU (Instruction for Use) is available on Hilti Online. Please check for any revisions before installing the product.

MT-TL Twist-Lock channel Nut

1

MT-TL M10 / MT-ML M10 OC

t	MT-TLB	L
3 - 6 mm	MT-TLB	24 mm
6 - 8 mm	MT-TLB 30	30 mm

MT-TL M10	MT-TLB / MT-TLB 30	30 Nm (22 ft-lb)	SI-AT-A22 SI-AT-22
MT-TL M10 OC	MT-TLB OC / MT-TLB 30 OC	40 Nm (30 ft-lb)	SI-AT-A22 SI-AT-22

The latest IFU (Instruction for Use) is available on Hilti Online. Please check for any revisions before installing the product.

MT-TL M12 OC / MT-TL M16 OC / MT-TL M 1/2" OC / MT-TL 5/8" OC

	A sw (8.8)	B
MT-TL M12	60 Nm (44 ft-lb)	30 Nm (22 ft-lb)
MT-TL M1/2 OC		
MT-TL M16		
MT-TL M 5/8 OC	90 Nm (66 ft-lb)	50 Nm (37 ft-lb)
MT-TL M16 OC		
MT-TL M 5/8 OC		

The latest IFU (Instruction for Use) is available on Hilti Online. Please check for any revisions before installing the product.

MT Box Profiles Connectors

90° Connectors - Outdoor

1

Operation Instruction MT-THB OC

2436930-04.2024

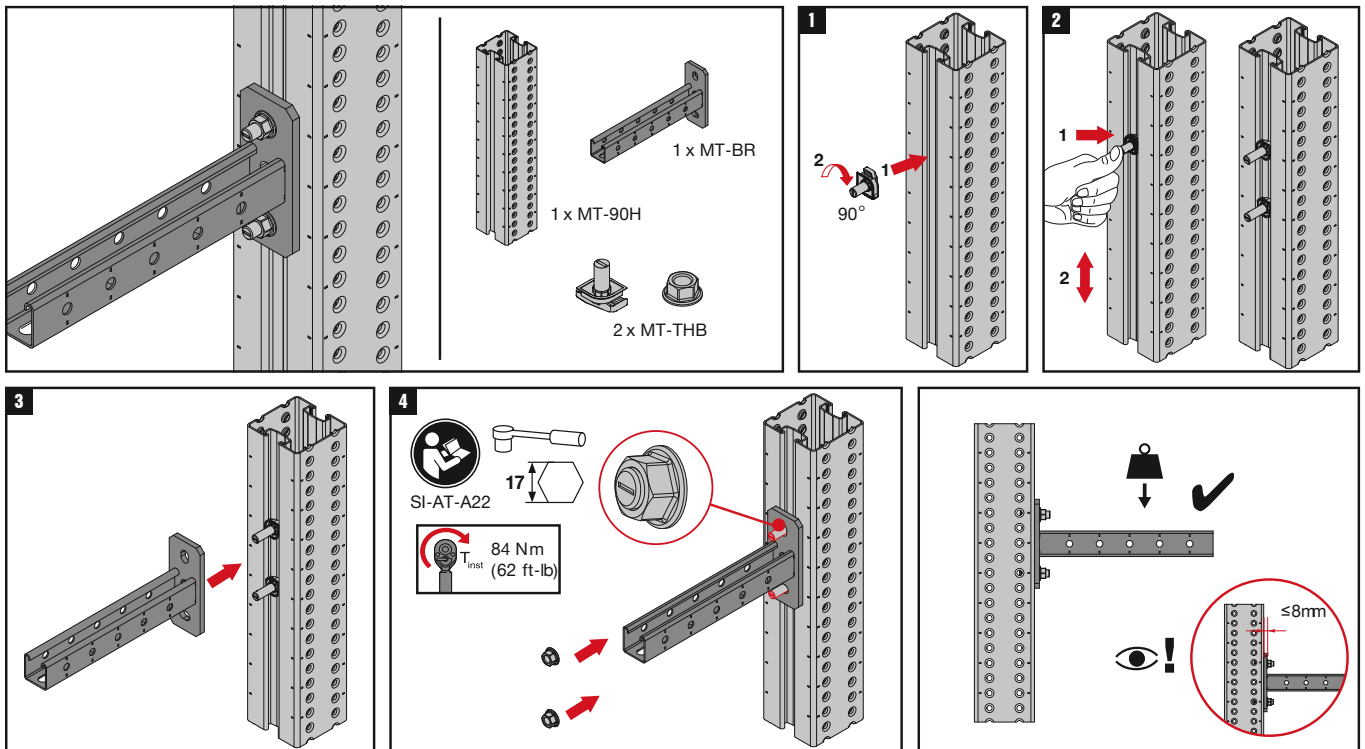

The latest IFU (Instruction for Use) is available on Hilti Online. Please check for any revisions before installing the product.

MT-TFB

2294557-08.2022

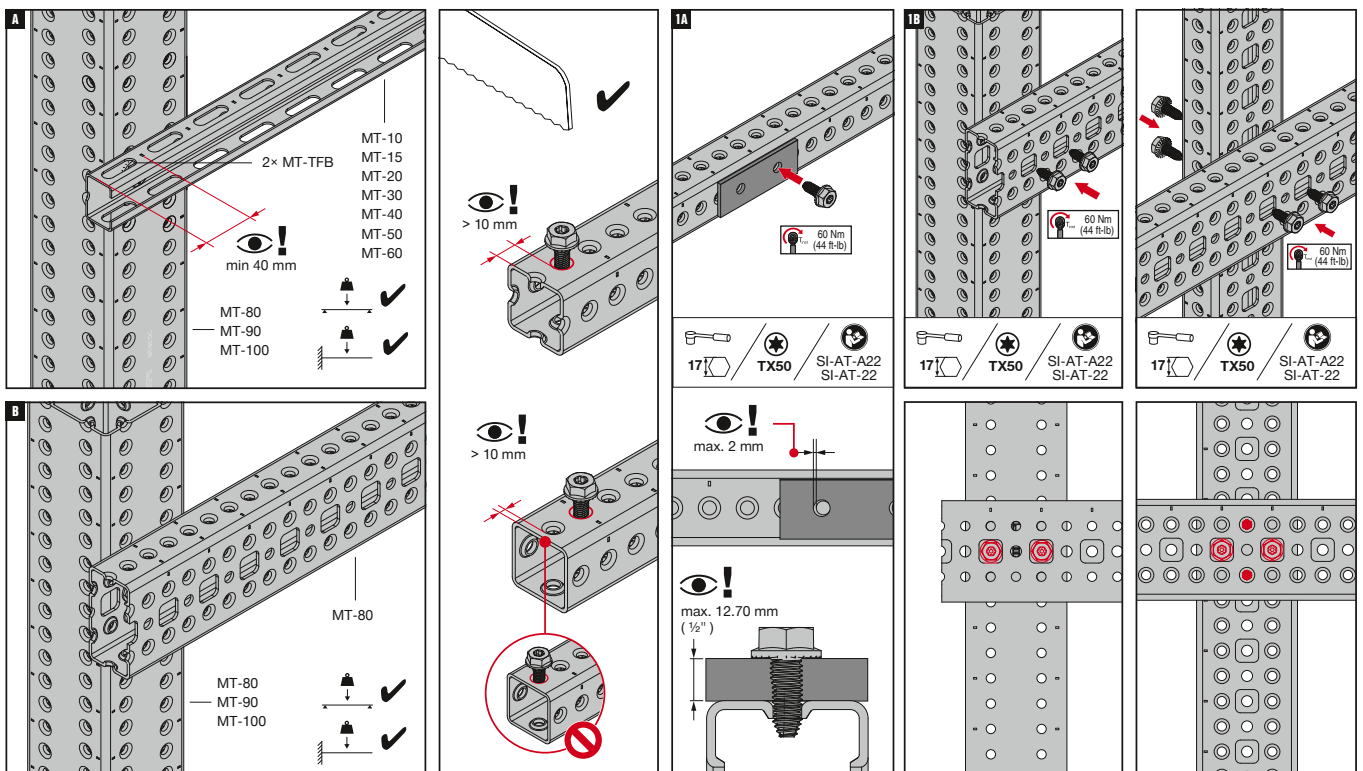

The latest IFU (Instruction for Use) is available on Hilti Online. Please check for any revisions before installing the product.

2. MT Profiles

2

MT Trapeze Profiles

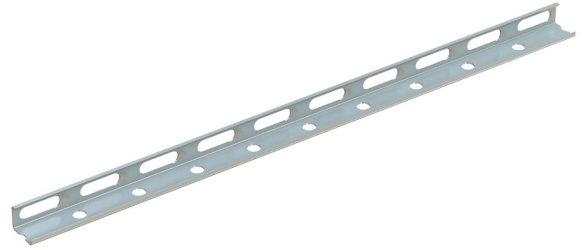
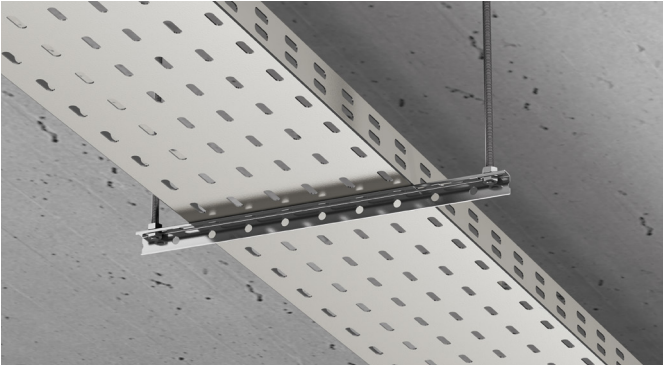

Applications

- Trapeze Channel to support pipes, ducts and cable trays in dry, indoor environments
- Suitable for use in dry, indoor environments

Advantages

- Economical – high load/weight ratio and rapid assembly make MT Trapeze Profile a more efficient alternative to welded MEP support structures
- Complexity kept to the minimum – optimizing logistical and on-site operations, as well as providing simplicity in installation
- Economical solution for simple threaded rod Trapeze frames
- Fully compatible with the MT System – direct mounting on MT girders possible

Technical data

Material composition	S280GD or better steel
Surface finish	Indoor Coated - Pre-galvanized (Z275)

MT-10 Trapeze Profile

Order Designation	Technical data	Sales pack quantity	Item number	
MT-10	Dry indoor conditions (C1) Indoor with temporary condensation (C2)	1x 2 m	2268492	
MT-10 S		1x 3 m	2360728	

MT-15 Trapeze Profile

Order Designation	Technical data	Sales pack quantity	Item number	
MT-15	Dry indoor conditions (C1) Indoor with temporary condensation (C2)	1x 2 m	2268493	
MT-15 S		1x 3 m	2360729	

MT Trapeze Profiles - Outdoor

2



Applications

- Trapeze Channel to support pipes, ducts and cable trays
- Suitable for use in moderately corrosive environments

Advantages

- Economical – high load/weight ratio and rapid assembly make MT C-Channel a more efficient alternative to welded MEP support structures
- Complexity kept to the minimum – optimizing logistical and on-site operations, as well as providing simplicity in installation
- Economical solution for threaded rod Trapeze frames

Technical data

Material composition	S280GD or better
Surface finish	Zinc-Magnesium (ZM310)- for outdoor use

MT-15 OC Trapeze Profile - Outdoor

Order Designations	Technical data	Sales pack quantity	Item number	
MT-15 OC	Outdoor, low to moderate pollution (C3 / C4 - low)	1x 2 m	2268494	
MT-15 S OC		1x 3 m	2360920	

MT-20 OC Trapeze Profile - Outdoor

Order Designation	Technical data	Sales pack quantity	Item number	
MT-20 OC	Outdoor, low to moderate pollution (C3 / C4 - low)	1x 2 m	2268496	
MT-20 S OC		1x 3 m	2360922	

MT-40 T OC Trapeze Profile - Outdoor

Order Designation	Technical data	Sales pack quantity	Item number	
MT-40 T S OC	Outdoor, low to moderate pollution (C3 / C4 - low)	1x 3 m	2360924	
MT-40 T OC		1x 6 m	2268504	

MT Open C-Channels - Outdoor

2

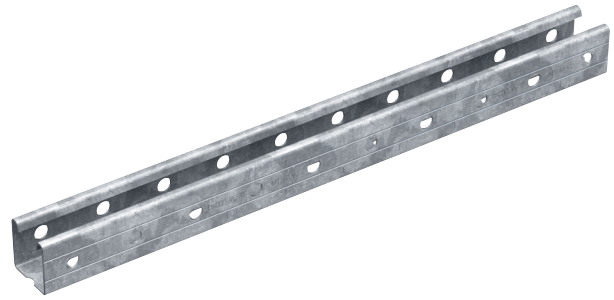
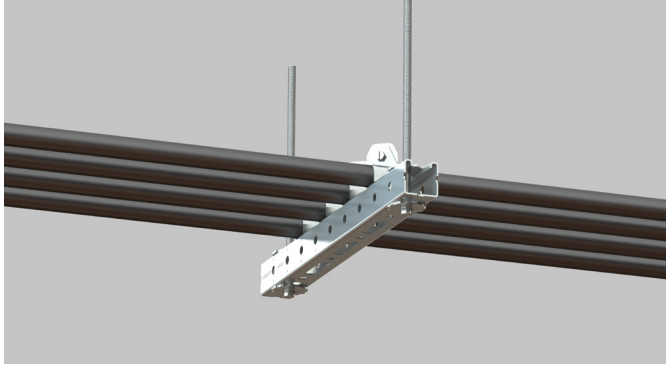

Applications

- Floor-mounted MEP support structures with lighter loads and limited spans, such as goal post-type strut framing
- Ceiling-mounted MEP support structures with lighter loads and limited spans, such as suspended strut Trapeze frames
- Wall-mounted cantilever Brackets for smaller pipes, ducts and cables

Technical data

Material composition	S280GD or better steel
Surface finish	Zinc-Magnesium (ZM310)- for outdoor use

Advantages

- Economical – high load/weight ratio and rapid assembly make MT C-Channel a more efficient alternative to welded MEP support structures
- Complexity kept to the minimum – optimizing logistical and on-site operations, as well as providing simplicity in installation
- Simpler to design – you can use Hilti MT components for all MEP installations from the lightest Trapeze to the heaviest-duty modular framing
- Simpler to install – compatible with the innovative MT System Twist-Lock, enabling the use of a wide range of MT Connectors and baseplates
- Easier identification – added lines along the sides of the C-Channel profile to help identify load classes and provide a more aesthetic finish

MT-30 Open C-Channel - Outdoor

Order Designation	Technical data	Sales pack quantity	Item number	
MT-30 S OC	Outdoor, low to moderate pollution (C3 / C4 - low)	1x 3 m	2268499	
MT-30 OC		1x 6 m	2268500	

MT-40 Open C-Channel - Outdoor

Order Designation	Technical data	Sales pack quantity	Item number	
MT-40 S OC	Outdoor, low to moderate pollution (C3 / C4 - low)	1x 3 m	2268507	
MT-40 OC		1x 6 m	2268508	

MT Open double C-Channel

2

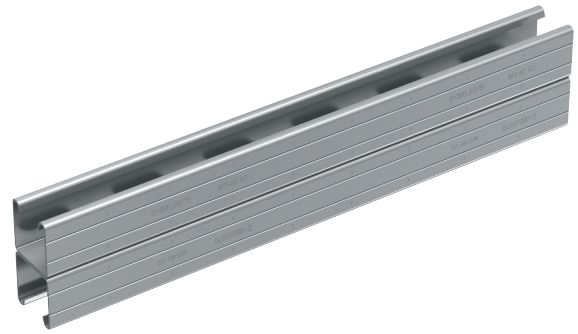

Applications

- Floor-mounted MEP support structures, such as goal post-type strut framing
- Ceiling-mounted MEP support structures, such as suspended Trapeze Channel frames
- Wall-mounted cantilever Brackets for heavier pipes

Advantages

- Economical – high load/weight ratio and rapid assembly make MT C-Channel a more efficient alternative to welded MEP support structures
- Complexity kept to the minimum – optimizing logistical and on-site operations, as well as providing simplicity in installation
- Simpler to design – you can use Hilti MT components for all MEP installations from the lightest Trapeze to the heaviest-duty modular framing
- Simpler to install – compatible with the innovative MT System Twist-Lock, enabling the use of a wide range of MT Connectors and baseplates
- Easier identification – added lines along the sides of the C-Channel profile to help identify load classes and provide a more aesthetic finish

Technical data

Material composition	S280 or better steel
Surface finish	Indoor Coated - Pre-galvanized (Z275)

MT-30 Open double C-Channel

Order Designation	Technical data	Sales pack quantity	Item number	
MT-30D S	Dry indoor conditions (C1) Indoor with temporary condensation (C2)	1x 3 m	2362708	
MT-30D		1x 6 m	2362706	

MT-40 Open double C-Channel

Order Designation	Technical data	Sales pack quantity	Item number	
MT-40D S	Dry indoor conditions (C1) Indoor with temporary condensation (C2)	1x 3 m	2268517	
MT-40D		1x 6 m	2268518	

MT-40 V2 Open double C-Channel

Order Designation	Technical data	Sales pack quantity	Item number	
MT-40D V2 S	Dry indoor conditions (C1) Indoor with temporary condensation (C2)	1x 3 m	2465577	
MT-40D V2		1x 6 m	2465791	

MT-50 Open double C-Channel

Order Designation	Technical data	Sales pack quantity	Item number	
MT-50D S	Dry indoor conditions (C1) Indoor with temporary condensation (C2)	1x 3 m	2362804	
MT-50D		1x 6 m	2362803	

MT-50 U Open double C-Channel

Order Designation	Technical data	Sales pack quantity	Item number	
MT-50D U	Dry indoor conditions (C1) Indoor with temporary condensation (C2)	1x 6 m	2362807	

MT-60 Open double C-Channel

Order Designation	Technical data	Sales pack quantity	Item number	
MT-60D S	Dry indoor conditions (C1) Indoor with temporary condensation (C2)	1x 3 m	2362802	
MT-60D		1x 6 m	2362800	

MT Open double C-Channel - Outdoor

2

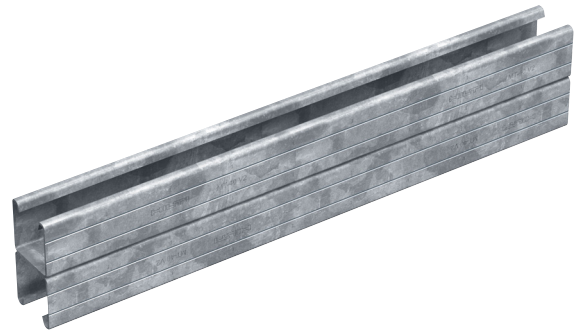

Applications

- Floor-mounted MEP support structures, such as goal post-type strut framing
- Ceiling-mounted MEP support structures, such as suspended strut Trapeze frames
- Wall-mounted cantilever Brackets for heavier pipes

Technical data

Material composition	S280 or better steel
Surface finish	Zinc-Magnesium (ZM310) - for outdoor use

Advantages

- Economical – high load/weight ratio and rapid assembly make MT strut Channel a more efficient alternative to welded MEP support structures
- Complexity kept to the minimum – optimizing logistical and on-site operations, as well as providing simplicity in installation
- Simpler to design – you can use Hilti MT components for all MEP installations from the lightest Trapeze to the heaviest-duty modular framing
- Simpler to install – compatible with the innovative MT System Twist-Lock, enabling the use of a wide range of MT Connectors and baseplates
- Easier identification – added lines along the sides of the C-Channel profile to help identify load classes and provide a more aesthetic finish

MT-30 Open double C-Channel - Outdoor

Order Designation	Technical data	Sales pack quantity	Item number	
MT-30D S OC	Outdoor, low to moderate pollution (C3 / C4 - low)	1x 3 m	2362709	
MT-30D OC		1x 6 m	2362707	

MT-40 Open double C-Channel - Outdoor

Order Designation	Technical data	Sales pack quantity	Item number	
MT-40D S OC	Outdoor, low to moderate pollution (C3 / C4 - low)	1x 3 m	2268519	
MT-40D OC		1x 6 m	2268520	

MT-40 V2 Open double C-Channel - Outdoor

Order Designation	Technical data	Sales pack quantity	Item number	
MT-40D V2 S OC	Outdoor, low to moderate pollution (C3 / C4 - low)	1x 3 m	2465792	
MT-40D V2 OC		1x 6 m	2465578	

MT-60 double C-Channel - Outdoor

Order Designation	Technical data	Sales pack quantity	Item number	
MT-60D OC	Dry indoor conditions (C1) Indoor with temporary condensation (C2)	1x 6 m	2362801	

MT Box Profiles - Outdoor

2

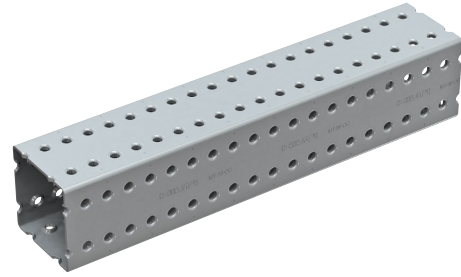
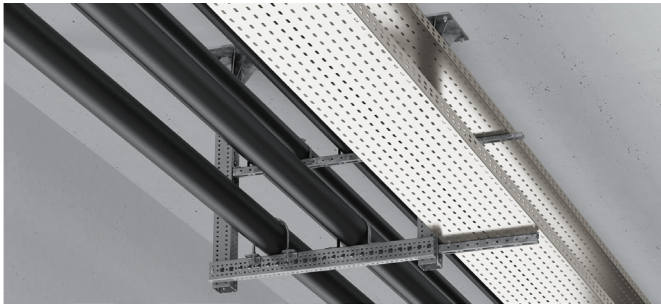

Applications

- Floor-mounted MEP support structures, such as goal post-type strut framing
- Ceiling-mounted MEP support structures, such as suspended rapeze Channel frames
- Wall-mounted cantilever Brackets for heavier pipes

Advantages

- Economical – high load/weight ratio make MT Box Profiles an efficient alternative to welding for virtually any heavy-duty MEP supports and modular structures
- Complexity kept to the minimum – optimizing logistical and on-site operations, as well as providing simplicity in installation
- Simpler to design – you can use Hilti MT components for all MEP installations from the lightest Trapeze to the heaviest-duty modular framing
- Simpler to install – compatible with the innovative MT thread-forming bolt, enabling the use of a wide range of MT Connectors and baseplates, and avoiding the need for nuts

Technical data

Material composition	S350 or better steel
Surface finish	Zinc-Magnesium (ZM310) for outdoor use

MT-70 Box Profile - Outdoor

Order Designation	Technical data	Sales pack quantity	Item number
MT-70 S OC	Outdoor, low to moderate pollution (C3 / C4 - low)	1x 3 m	2268364
MT-70 OC		1x 6 m	2268365

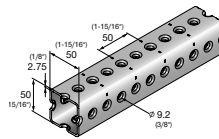

MT-80 Box Profile - Outdoor

Order Designation	Technical data	Sales pack quantity	Item number
MT-80 S OC	Outdoor, low to moderate pollution (C3 / C4 - low)	1x 3 m	2268366
MT-80 OC		1x 6 m	2268367

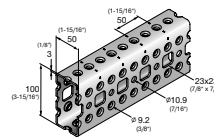

MT Box Profiles - Outdoor

2

MT-90 Box Profile - Outdoor

Order Designation	Technical data	Sales pack quantity	Item number	
MT-90 S OC	Outdoor, low to moderate pollution (C3 / C4 - low)	1x 3 m	2268368	
MT-90 OC		1x 6 m	2268369	

MT-90H Box Profile - Outdoor

Order Designation	Technical data	Sales pack quantity	Item number	
MT-90H S OC	Outdoor, low to moderate pollution (C3 / C4 - low)	1x 3 m	2431073	
MT-90H OC		1x 6 m	2430776	

MT-100 Box Profile - Outdoor

Order Designation	Technical data	Sales pack quantity	Item number	
MT-100 S OC	Outdoor, low to moderate pollution (C3 / C4 - low)	1x 3 m	2268490	
MT-100 OC		1x 6 m	2268491	

Overview MT Trapeze Profiles, Open C-channels, Box Profiles

2

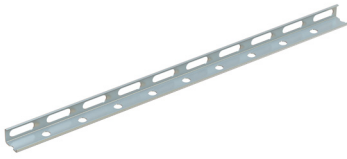

MT 10 - 2268492 (2 meter)
MT 10 S - 2360728 (3 meter)

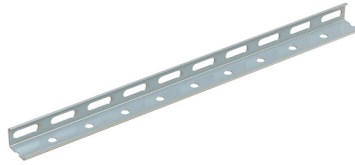

MT 15 - 2268493 (2 meter)
MT 15 S - 2360729 (3 meter)
MT 15 OC - 2268494 (2 meter)
MT 15 S OC - 2360920 (3 meter)

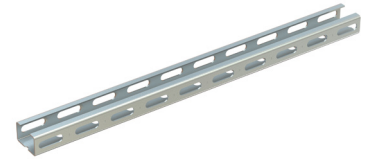

MT 20 - 2268495 (2 meter)
MT 20 S - 2360921 (3 meter)
MT 20 OC - 2268496 (2 meter)
MT 20 S OC - 2360922 (3 meter)



MT 40 T - 2268502 (6 meter)
MT 40 T S - 2360923 (3 meter)
MT 40 T OC - 2268504 (6 meter)
MT 40 T S OC - 2360924 (3 meter)



MT 30 - 2268498 (6 meter)
MT 30 S - 2268497 (3 meter)
MT 30 OC - 2268500 (6 meter)
MT 30 S OC - 2268499 (3 meter)



MT 30D - 2362706 (6 meter)
MT 30D S - 2362708 (3 meter)
MT 30D OC - 232707 (6 meter)
MT 30D S OC - 2362709 (3 meter)



MT 40 - 2268506 (6 meter)
MT 40 S - 2268505 (3 meter)
MT 40 OC - 2268508 (6 meter)
MT 40 S OC - 2268507 (3 meter)



MT 40D - 2268518 (6 meter)
MT 40D S - 2268517 (3 meter)
MT 40D OC - 2268520 (6 meter)
MT 40D S OC - 2268519 (3 meter)



MT 50 - 2268510 (6 meter)
MT 50 S - 2268509 (3 meter)
MT 50 OC - 2268512 (6 meter)
MT 50 S OC - 2268511 (3 meter)

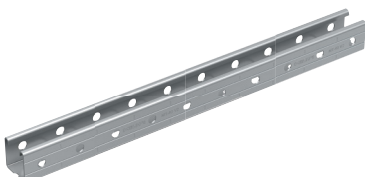

MT 40 V2 - 2465581 (6 meter)
MT 40 V2 S - 2465567 (3 meter)
MT 40 V2 OC - 2465569 (6 meter)
MT 40 V2 S OC - 2465568 (3 meter)

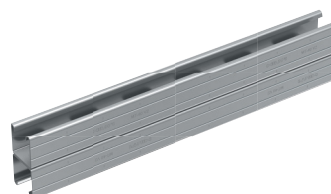

MT 40D V2 - 2465791 (6 meter)
MT 40D V2 S - 2465577 (3 meter)
MT 40D V2 OC - 2465578 (6 meter)
MT 40D V2 S OC - 2465792 (3 meter)



MT 50D - 2362803 (6 meter)
MT 50D S - 2362804 (3 meter)



MT 50U - 2362808 (6 meter)
MT 50D U - 2362807 (6 meter)



MT 60 - 2268514 (6 meter)
MT 60 S - 2268513 (3 meter)
MT 60 OC - 2268516 (6 meter)
MT 60 S OC - 2268515 (3 meter)



MT 60D - 2362800 (6 meter)
MT 60D OC - 2362801 (6 meter)
MT 60D S - 2362802 (3 meter)

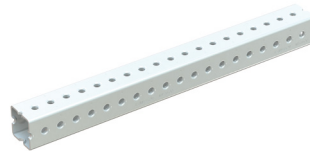

MT 70 OC - 2268365 (6 meter)
MT 70 S OC - 2268364 (3 meter)

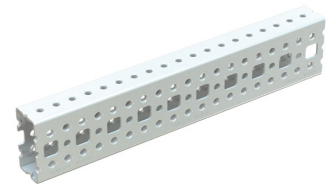

MT 80 OC - 2268367 (6 meter)
MT 80 S OC - 2268366 (3 meter)

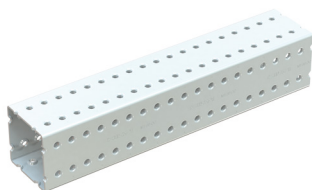

MT 90 OC - 2268369 (6 meter)
MT 90 S OC - 2268368 (3 meter)

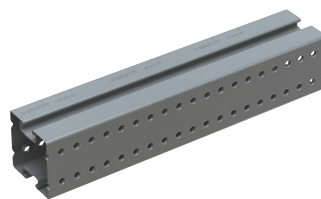

MT 90H OC - 2430776 (6 meter)
MT 90H S OC - 2431073 (3 meter)

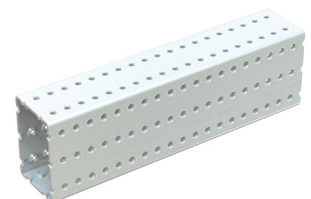

MT 100 OC - 2268491 (6 meter)
MT 100 S OC - 2268490 (3 meter)

Technical Data for MT Profiles (pregalvanized & zinc magnesium)

2

Trapeze Profiles

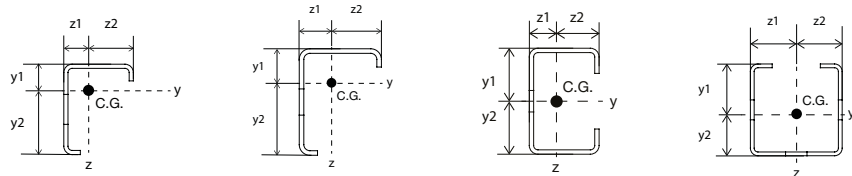

			MT-10	MT-15/ MT-15 OC	MT-20/ MT-20 OC	MT-40 T/ MT-40 T OC
Wall thickness	t	[mm]	1,2	1,5	1,75	1,75
Cross-sectional area	A	[mm ²]	48,43	85,2	148,65	175,59
channel weight		[kg/m]	0,3888	0,6784	1,267	1,69
Delivered length		[m]	2	2/3	2/3	3/6
Material properties						
Steel grade			S280GD	S280GD	S280GD	S280GD
Recommended stress	σ_{rec}	[N/mm ²]	207,8	206,7	205,8	200,5
Elasticity modulus	E	[N/mm ²]	210000	210000	210000	210000
Corrosion protection						
pregalvanized (EN 10346)			•	•	•	•
zinc magnesium (EN 10346)				•	•	•
Cross-section values Y-axis						
Axis of gravity	y1	[mm]	9,25	11,90	21,25	23,05
Axis of gravity	y2	[mm]	16,75	23,10	21,25	19,45
Moment of inertia	I_y	[cm ⁴]	0,40	1,27	3,65	4,84
Section modulus	W_{y1}	[cm ³]	0,25	0,57	1,73	2,10
Section modulus	W_{y2}	[cm ³]	0,41	1,00	1,73	2,48
Radius of gyration	i_y	[cm]	0,91	1,22	1,57	1,66
Recommended moment ²⁾	$M_{y,rec}$	[Nm]	52	118	355	421
Cross-section values Z-axis						
Axis of gravity	z1	[mm]	5,2	7,0	10,5	21,25
Axis of gravity	z2	[mm]	14,8	20,0	17,3	21,25
Moment of inertia	I_{z1}	[cm ⁴]	0,23	0,72	1,85	5,71
Section modulus	W_{z1}	[cm ³]	0,15	0,36	1,07	2,69
Section modulus	W_{z2}	[cm ³]	0,45	1,03	1,07	2,69
Radius of gyration	i_z	[cm]	0,69	0,92	1,12	1,80

Design notes Open Profiles

- Where applicable recommended values consider partial safety factors for actions and resistance
- Recommended stress (σ_{rec}) is determined using $\sigma_{rec} = (f_{yd}) / [(Y_{M1}) \times (Y_{M2})]$ where

f_{yd} average yield strength (EN 1993-1-3:2024)
 $Y_{M1} = 1,1$ partial Safety Factor for global buckling (DIN EN 1993-1-3:2006)
 $Y_{M2} = 1,4$ partial Safety Factor for action loading

Recommended moment ($M_{y,Rec}$)

$M_{y,Rec} = (\sigma_{Rec}) \times (W_y)$ where
 σ_{Rec} recommended Stress
 W_y minimum section modulus (W_{y1}, W_{y2})

For further details behind calculations using this design method, please consult a Hilti engineer.

Technical Data for MT Profiles (pregalvanized & zinc magnesium)

2

Open C-channels

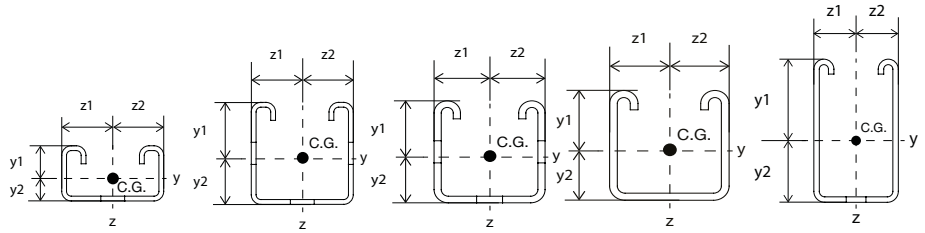

			MT-30/ MT-30 OC	MT-40 MT-40 OC	MT-50/ MT-50 OC	MT-50 U	MT-60/ MT-60 OC
channel wall thickness	t	[mm]	2,0	2,0	2,75	2,75	2,75
Cross-sectional area	A	[mm ²]	180	214	276,05	276,05	498,77
channel weight		[kg/m]	1,486	1,800	2,744	2,744	4,017
Delivered length		[m]	3/6	3/6	3/6	3/6	3/6
Material properties							
Steel grade			S280GD	S280GD	S280GD	S280GD	S280GD
Recommended stress	σ_{rec}	[N/mm ²]	205,8	202,2	207,8	207,8	202,3
Elasticity modulus	E	[N/mm ²]	210000	210000	210000	210000	210000
Corrosion protection							
pregalvanized (EN 10346)			•	•	•	•	•
zinc magnesium (EN 10346)			•	•	•		•
Cross-section values Y-axis							
Axis of gravity	y1	[mm]	12,04	21,76	22,04	22,04	36,61
Axis of gravity	y2	[mm]	10,96	20,74	20,46	20,46	35,39
Moment of inertia	I_y	[cm ⁴]	1,21	5,77	7,04	7,04	28,57
Section modulus	W_{y1}	[cm ³]	1,00	2,65	3,19	3,19	7,80
Section modulus	W_{y2}	[cm ³]	1,10	2,78	3,44	3,44	8,07
Plastic section modulus	$W_{pl,y}$	[cm ³]	1,36	3,37	4,22	4,22	10,56
Radius of gyration	i_y	[cm]	0,82	1,64	1,60	1,60	2,39
Recommended moment ¹⁾	$M_{y,rec}$	[Nm]	208	536	876	876	1436
Cross-section values Z-axis							
Axis of gravity	z1	[mm]	21,25	21,25	21,25	21,25	21,25
Axis of gravity	z2	[mm]	21,25	21,25	21,25	21,25	21,25
Moment of inertia	I_{z1}	[cm ⁴]	5,19	6,59	8,27	8,27	16,01
Section modulus	W_{z1}	[cm ³]	2,44	3,10	3,89	3,89	8,04
Section modulus	W_{z2}	[cm ³]	2,44	3,10	3,89	3,89	8,04
Radius of gyration	i_z	[cm]	1,70	1,76	1,73	1,73	1,85

Design notes Open Profiles

• Where applicable recommended values consider partial safety factors for actions and resistance

• Recommended stress (σ_{rec}) is determined using $\sigma_{rec} = (f_{yd}) / [(Y_{Hilti}) \times (Y_m)]$ where

f_{yd} average yield strength (EN 1993-1-3:2024)
 $Y_m = 1,1$ partial Safety Factor for global buckling (DIN EN 1993-1-3:2006)
 $Y_{Hilti} = 1,4$ partial Safety Factor for action loading

Recommended moment ($M_{y,Rec}$)

¹⁾ $M_{y,Rec} = M_{c,Rk} / (Y_{M,y,Hilti})$ where
 $M_{c,Rk} = (W_{el} \cdot f_{yb} + 3(W_{pl} \cdot F_{ya} - W_{el} \cdot f_{yb})) \cdot (1 - (\lambda_y / \lambda_{ey}) \max)$ (EN 1993-1-3:2024)
 f_{yb} basic yield strength (EN 1993-1-3:2024)

For further details behind calculations using this design method, please consult a Hilti engineer.

Technical Data for MT Profiles (pregalvanized & zinc magnesium)

2

Open C-channels

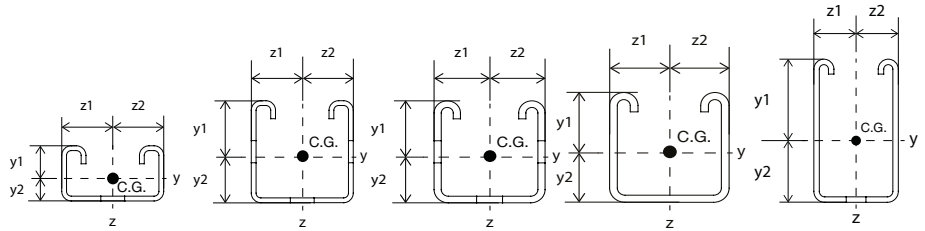

			MT-30/ MT-30 OC	MT-40 V2 MT-40 V2 OC	MT-50/ MT-50 OC	MT-50 U	MT-60/ MT-60 OC
channel wall thickness	t	[mm]	2,0	1,75	2,75	2,75	2,75
Cross-sectional area	A	[mm ²]	180	187,42	276,05	276,05	498,77
channel weight		[kg/m]	1,486	1,800	2,744	2,744	4,017
Delivered length		[m]	3/6	3/6	3/6	3/6	3/6
Material properties							
Steel grade			S280GD	S280GD	S280GD	S280GD	S280GD
Recommended stress	σ_{rec}	[N/mm ²]	205,8	199,7	207,8	207,8	202,3
Elasticity modulus	E	[N/mm ²]	210000	210000	210000	210000	210000
Corrosion protection							
pregalvanized (EN 10346)			•	•	•	•	•
zinc magnesium (EN 10346)			•	•	•		•
Cross-section values Y-axis							
Axis of gravity	y1	[mm]	12,04	21,99	22,04	22,04	36,61
Axis of gravity	y2	[mm]	10,96	20,51	20,46	20,46	35,39
Moment of inertia	I_y	[cm ⁴]	1,21	5,08	7,04	7,04	28,57
Section modulus	W_{y1}	[cm ³]	1,00	2,31	3,19	3,19	7,80
Section modulus	W_{y2}	[cm ³]	1,10	2,48	3,44	3,44	8,07
Plastic section modulus	$W_{pl,y}$	[cm ³]	1,36	2,94	4,22	4,22	10,56
Radius of gyration	i_y	[cm]	0,82	1,64	1,60	1,60	2,39
Recommended moment ¹⁾	$M_{y,rec}$	[Nm]	208	536	876	876	1436
Cross-section values Z-axis							
Axis of gravity	z1	[mm]	21,25	21,25	21,25	21,25	21,25
Axis of gravity	z2	[mm]	21,25	21,25	21,25	21,25	21,25
Moment of inertia	I_{z1}	[cm ⁴]	5,19	5,77	8,27	8,27	16,01
Section modulus	W_{z1}	[cm ³]	2,44	2,72	3,89	3,89	8,04
Section modulus	W_{z2}	[cm ³]	2,44	2,72	3,89	3,89	8,04
Radius of gyration	i_z	[cm]	1,70	17,55	1,73	1,73	1,85

Design notes Open Profiles

• Where applicable recommended values consider partial safety factors for actions and resistance

• Recommended stress (σ_{rec}) is determined using $\sigma_{rec} = (f_{ya}) / [(Y_{Hilti}) \times (Y_m)]$ where

f_{ya} average yield strength (EN 1993-1-3:2024)
 $Y_m = 1,1$ partial Safety Factor for global buckling (DIN EN 1993-1-3:2006)
 $Y_{Hilti} = 1,4$ partial Safety Factor for action loading

Recommended moment ($M_{y,Rec}$)

¹⁾ $M_{y,Rec} = M_{c,Rk} / (Y_{M,Y_{Hilti}})$ where
 $M_{c,Rk} = (W_{el} \cdot f_{yb} + 3(W_{pl} \cdot F_{ya} - W_{el} \cdot f_{yb})) \cdot (1 - (\lambda_0 / \lambda_{e0}) \max)$ (EN 1993-1-3:2024)
 f_{yb} basic yield strength (EN 1993-1-3:2024)

For further details behind calculations using this design method, please consult a Hilti engineer.

Technical Data for MT Profiles (pregalvanized & zinc magnesium)

2

double channels

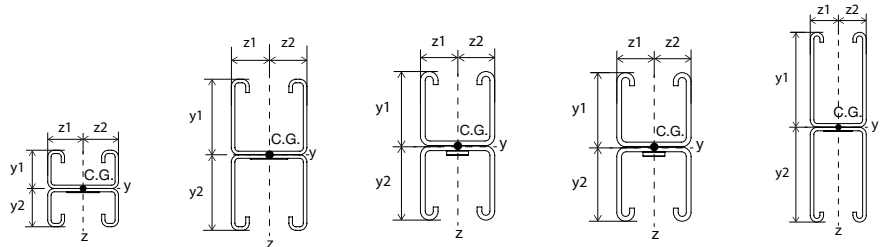

		MT-30 D/ MT-30 D OC	MT-40D MT-40D OC	MT-50D	MT-50D U	MT-60D/ MT-60D OC
channel wall thickness	t [mm]	2,0	2,0	2,75	675,73	2,75
Cross-sectional area	A [mm ²]	361,52	517,92	675,73	675,73	1000,19
channel weight	[kg/m]	2,97	4,299	5,49	5,49	8,03
Delivered length	[m]	3/6	3/6	3/6	3/6	3/6
Material properties						
Steel grade		S280GD	S280GD	S280GD	S280GD	S280GD
Recommended stress	σ_{rec} [N/mm ²]	205,8	202,2	207,8	207,8	202,3
Elasticity modulus	E [N/mm ²]	210000	210000	210000	210000	210000
Corrosion protection						
pregalvanized (EN 10346)		•	•	•	•	•
zinc magnesium (EN 10346)		•	•			•
Cross-section values Y-axis						
Axis of gravity	y1 [mm]	23,00	42,50	42,50	42,50	72,00
Axis of gravity	y2 [mm]	23,00	42,50	42,50	42,50	72,00
Moment of inertia	I_y [cm ⁴]	6,78	34,19	42,89	42,89	182,50
Section modulus	W_{y1} [cm ³]	2,95	8,04	10,09	10,09	25,35
Section modulus	W_{y2} [cm ³]	2,95	8,04	10,09	10,09	25,35
Plastic section modulus	$W_{pl,y}$ [cm ³]	3,97	10,79	13,90	13,90	35,37
Radius of gyration	i_y [cm]	1,37	2,57	2,52	2,52	4,23
Recommended moment ¹⁾	$M_{y,rec}$ [Nm]	607	1625	2889	2889	5185
Cross-section values Z-axis						
Axis of gravity	z1 [mm]	21,25	21,25	21,25	21,25	21,25
Axis of gravity	z2 [mm]	21,25	21,25	21,25	21,25	21,25
Moment of inertia	I_{z1} [cm ⁴]	10,29	13,18	21,19	21,19	33,27
Section modulus	W_{z1} [cm ³]	4,84	7,86	9,97	9,97	16,01
Section modulus	W_{z2} [cm ³]	4,84	7,86	9,97	9,97	16,01
Radius of gyration	i_z [cm]	1,69	1,80	1,77	1,77	1,84

Design notes Open Profiles

• Where applicable recommended values consider partial safety factors for actions and resistance

• Recommended stress (σ_{rec}) is determined using $\sigma_{rec} = (f_{yd}) / ((\gamma_{M1}) \times (\gamma_{M2}))$ where

f_{yd} average yield strength (EN 1993-1-3:2024)
 $\gamma_{M1} = 1,1$ partial Safety Factor for global buckling (DIN EN 1993-1-3:2006)
 $\gamma_{M2} = 1,4$ partial Safety Factor for action loading

Recommended moment ($M_{y,Rec}$)

¹⁾ $M_{y,rec} = M_{c,Rk} / (\gamma_{M1} \times \gamma_{M2})$ where
 $M_{c,Rk} = (W_{el} \times f_{yb} + 3(W_{pl} \times F_{yd} - W_{el} \times f_{yb})(1 - (\lambda_{ed}/\lambda_{e0} \max)))$ (EN 1993-1-3:2024)
 f_{yb} basic yield strength (EN 1993-1-3:2024)

For further details behind calculations using this design method, please consult a Hilti engineer.

Technical Data for MT Profiles (pregalvanized & zinc magnesium)

2

double channels

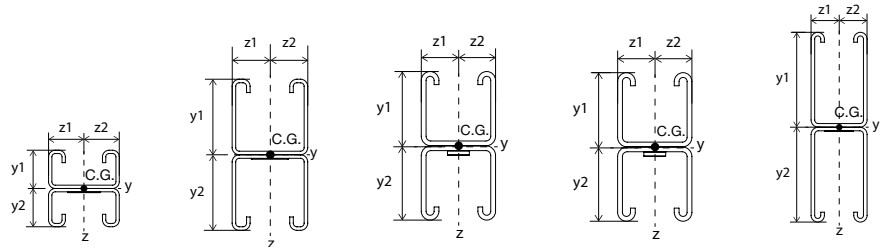

		MT-30 D/ MT-30 D OC	MT-40D V2/ MT-40D V2 OC	MT-50D	MT-50D U	MT-60D/ MT-60D OC
channel wall thickness	t [mm]	2,0	1,75	2,75	675,73	2,75
Cross-sectional area	A [mm ²]	361,52	451,85	675,73	675,73	1000,19
channel weight	[kg/m]	2,97	3,000	5,49	5,49	8,03
Delivered length	[m]	3/6	3/6	3/6	3/6	3/6
Material properties						
Steel grade		S280GD	S280GD	S280GD	S280GD	S280GD
Recommended stress	σ_{rec} [N/mm ²]	205,8	199,7	207,8	207,8	202,3
Elasticity modulus	E [N/mm ²]	210000	210000	210000	210000	210000
Corrosion protection						
pregalvanized (EN 10346)		•	•	•	•	•
zinc magnesium (EN 10346)		•	•			•
Cross-section values Y-axis						
Axis of gravity	y1 [mm]	23,00	42,50	42,50	42,50	72,00
Axis of gravity	y2 [mm]	23,00	42,50	42,50	42,50	72,00
Moment of inertia	I_y [cm ⁴]	6,78	29,41	42,89	42,89	182,50
Section modulus	W_{y1} [cm ³]	2,95	6,92	10,09	10,09	25,35
Section modulus	W_{y2} [cm ³]	2,95	6,92	10,09	10,09	25,35
Plastic section modulus	$W_{pl,y}$ [cm ³]	3,97	9,30	13,90	13,90	35,37
Radius of gyration	i_y [cm]	1,37	2,55	2,52	2,52	4,23
Recommended moment ¹⁾	$M_{y,rec}$ [Nm]	607	1742	2889	2889	5185
Cross-section values Z-axis						
Axis of gravity	z1 [mm]	21,25	21,25	21,25	21,25	21,25
Axis of gravity	z2 [mm]	21,25	21,25	21,25	21,25	21,25
Moment of inertia	I_{z1} [cm ⁴]	10,29	14,87	21,19	21,19	33,27
Section modulus	W_{z1} [cm ³]	4,84	7,00	9,97	9,97	16,01
Section modulus	W_{z2} [cm ³]	4,84	7,00	9,97	9,97	16,01
Radius of gyration	i_z [cm]	1,69	1,81	1,77	1,77	1,84

Design notes Open Profiles

• Where applicable recommended values consider partial safety factors for actions and resistance

• Recommended stress (σ_{rec}) is determined using $\sigma_{rec} = (f_{yb}) / ((\gamma_{Hilti}) \times (\gamma_m))$ where

f_{yb} average yield strength (EN 1993-1-3:2024)
 $\gamma_m = 1,1$ partial Safety Factor for global buckling (DIN EN 1993-1-3:2006)
 $\gamma_{Hilti} = 1,4$ partial Safety Factor for action loading

Recommended moment ($M_{y,Rec}$)

¹⁾ $M_{y,Rec} = M_{c,Rk} / (\gamma_m \times \gamma_{Hilti})$ where
 $M_{c,Rk} = (W_{el} \times f_{yb} + 3(W_{pl} \times F_{yb} - W_{el} \times f_{yb})(1 - (\lambda_0/\lambda_{0c}) \max))$ (EN 1993-1-3:2024)
 f_{yb} basic yield strength (EN 1993-1-3:2024)

For further details behind calculations using this design method, please consult a Hilti engineer.

Technical Data for MT Profiles (pregalvanized & zinc magnesium)

2

Box Profiles

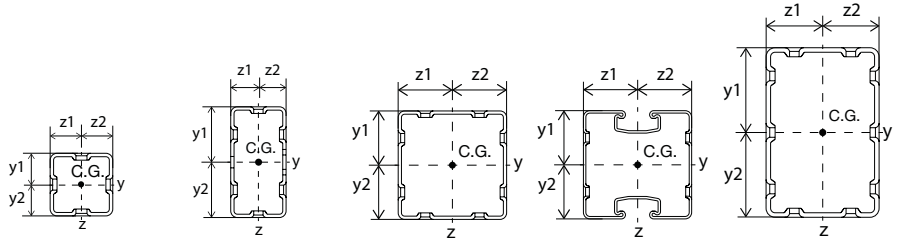

			MT-70 OC	MT-80 OC	MT-90 OC	MT-90H OC	MT-100 OC
Box wall thickness	t	[mm]	2,75	3,0	3,0	2,15	4,0
Cross-sectional area	A	[mm ²]	428,78	559,65	976,08	1060,2	1555,34
channel weight		[kg/m]	3,909	6,058	8,973	8,790	15,096
Delivered length		[m]	3/6	3/6	3/6	3/6	3/6
Material properties							
Steel grade			S350GD	S350GD	S350GD	S350GD	S350GD
Recommended stress	σ_{rec}	[N/mm ²]	227,3	233,3	233,3	230,9	233,3
Elasticity modulus	E	[N/mm ²]	210000	210000	210000	210000	210000
Corrosion protection							
pregalvanized (EN 10346)							
zinc magnesium (EN 10346)							
Cross-section values Y-axis							
Axis of gravity	y1	[mm]	25,00	50,00	50,00	50,0	75,00
Axis of gravity	y2	[mm]	25,00	50,00	50,00	50,0	75,00
Moment of inertia	I_y	[cm ⁴]	15,87	88,03	150,85	157,29	487,36
Section modulus	W_{y1}	[cm ³]	6,35	17,61	30,17	31,46	64,98
Section modulus	W_{y2}	[cm ³]	6,35	17,61	30,17	31,46	64,98
Plastic section modulus	$W_{pl,y}$	[cm ³]	7,79	21,09	34,99	38,48	78,93
Radius of gyration	i_y	[cm]	1,92	3,97	3,93	3,85	5,60
Recommended moment	$M_{y,rec}$	[Nm]	1771	4921	7666	8885	18416
Cross-section values Z-axis							
Axis of gravity	z1	[mm]	25,0	25,0	50,0	50,0	50,0
Axis of gravity	z2	[mm]	25,0	25,0	50,0	50,0	50,0
Moment of inertia	I_{z1}	[cm ⁴]	15,87	22,62	150,85	124,82	260,98
Section modulus	W_{z1}	[cm ³]	6,35	9,05	30,17	24,97	52,20
Section modulus	W_{z2}	[cm ³]	6,35	9,05	30,17	24,97	52,20
Radius of gyration	i_z	[cm]	1,92	2,01	3,93	3,43	4,10

Design notes Box Profiles

Recommended values consider partial safety factors for actions and resistance

$M_{y,Rec} = M_{e,Rk} / (\gamma_M \cdot \gamma_{Hilti})$ where
where

$M_{e,Rk} = (W_{el} \cdot f_{yb} + 3(W_{pl} \cdot F_{ys} - W_{el} \cdot f_{yb}) \cdot (1 - (\lambda_{el} / \lambda_{e0}) \max))$ (EN 1993-1-3:2024)

- f_{yb} basic yield strength (EN 1993-1-3:2024)
- f_{ys} average yield strength (EN 1993-1-3:2024)
- $\gamma_M = 1,0$ (MT-80, MT-90, MT-100); $1,1$ (MT-70, MT-90H)
- $\gamma_{Hilti} = 1,4$ (MT-70); $1,5$ (MT-80, MT-90, MT-90H, MT-100)
- partial Safety Factor for cross-sections (EN 1993-1-1:2022)
- partial Safety Factor for action loading

For further details behind calculations using this design method, please consult a Hilti engineer.

Technical Data for MT Profiles

(max. span width/deflection - point load in the middle of span)

Trapeze Profiles

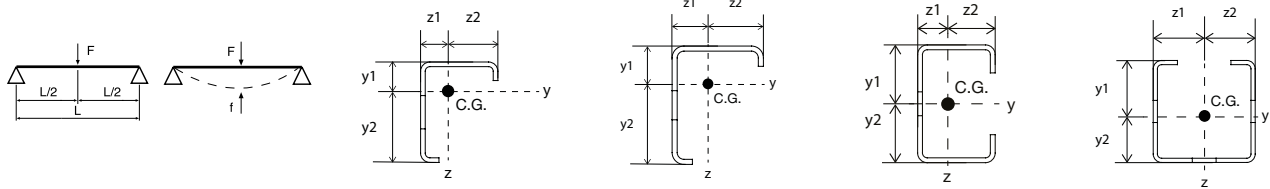

Max, span width L [cm] / deflection f [mm] - Result

load F [kN]	MT-10		MT-15/ MT-15 OC		MT-20/ MT-20 OC		MT-40 T/ MT-40 T OC	
	L	f	L	f	L	f	L	f
0,25	57	1,2	132	4,6	299	19,9	337	22,4
0,50	29	0,3	67	1,2	217	14,4	248	16,5
0,75	19	0,1	45	0,5	179	11,9	205	13,6
1,00	14	0,1	34	0,3	141	7,7	166	9,6
1,25	12	0,0	27	0,2	113	5,0	134	6,2
1,50	10	0,0	22	0,1	94	3,4	112	4,3
1,75	8	0,0	19	0,1	81	2,5	96	3,2
2,00	7	0,0	17	0,1	71	1,9	84	2,4
2,25	6	0,0	15	0,1	63	1,5	75	1,9
2,50	6	0,0	13	0,0	57	1,2	67	1,6
2,75	5	0,0	12	0,0	52	1,0	61	1,3
3,00	5	0,0	11	0,0	47	0,9	56	1,1
3,50	4	0,0	10	0,0	41	0,6	48	0,8
4,00	4	0,0	8	0,0	36	0,5	42	0,6
4,50	3	0,0	7	0,0	32	0,4	37	0,5
5,00	3	0,0	7	0,0	28	0,3	34	0,4
6,00	2	0,0	6	0,0	24	0,2	28	0,3
7,00	2	0,0	5	0,0	20	0,2	24	0,2
8,00	2	0,0	4	0,0	18	0,1	21	0,2

Design notes Open Profiles

- Where applicable recommended values consider partial safety factors for actions and resistance
- Recommended stress (σ_{rec}) is determined using $\sigma_{rec} = (f_{yd}) / ((\gamma_{red}) \times (\gamma_m))$ where
 - f_{yd} average yield strength (EN 1993-1-3:2024)
 - $\gamma_m = 1,1$ partial Safety Factor for global buckling (DIN EN 1993-1-3:2006)
 - $\gamma_{red} = 1,4$ partial Safety Factor for action loading

Selection example:

- 1,0 kN (\approx 100 kg) should be carried by a channel with a channel span width L = 100cm (single span simply supported).

Solution:

- Select the line with the load, F = 1,0 kN.
- The channels MT-20, MT-40 T up to MT-100 can be used because the recommended span width (table value) is larger or equal to the required span width of L = 100cm.

For further details behind calculations using this design method, please consult a Hilti engineer.

Technical Data for MT Profiles

(max. span width/deflection - point load in the middle of span)

Open C-channels

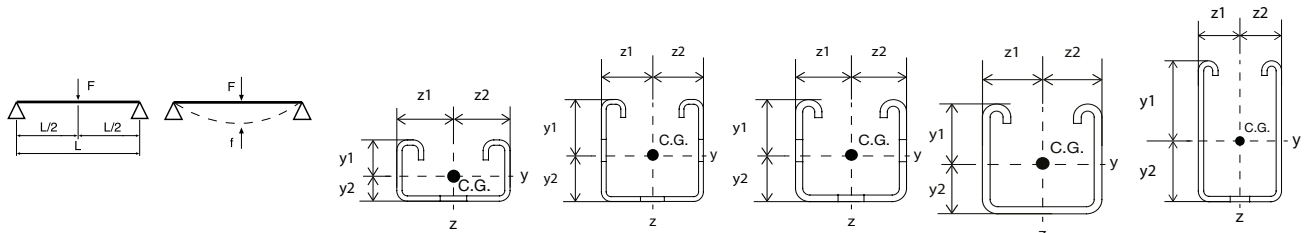

Max. span width L [cm] / deflection f [mm] - Result

load F [kN]	MT-30/ MT-30 OC		MT-40/ MT-40 OC		MT-50/ MT-50 OC		MT-50 U/ MT-50 U OC		MT-60/ MT-60 OC	
	L	f	L	f	L	f	L	f	L	f
0,25	174	11,5	361	23,9	386	25,6	386	25,6	600	30,1
0,50	126	8,4	269	17,9	293	19,5	293	19,5	548	36,4
0,75	103	6,8	223	14,8	244	16,2	244	16,2	470	31,3
1,00	83	4,6	194	12,9	213	14,1	213	14,1	416	27,6
1,25	66	3,0	169	10,6	191	12,6	191	12,6	377	25,0
1,50	55	2,1	142	7,4	175	11,6	175	11,6	347	23,0
1,75	47	1,5	122	5,5	163	10,9	163	10,9	317	20,2
2,00	41	1,2	107	4,2	152	10,0	152	10,0	279	15,7
2,25	37	0,9	95	3,3	144	9,6	144	9,6	250	12,5
2,50	33	0,7	86	2,7	136	8,9	136	8,9	226	10,2
2,75	30	0,6	78	2,2	127	7,9	127	7,9	206	8,5
3,00	28	0,5	71	1,9	116	6,7	116	6,7	189	7,1
3,50	24	0,4	61	1,4	100	4,9	100	4,9	163	5,3
4,00	21	0,3	54	1,1	87	3,8	87	3,8	143	4,1
4,50	18	0,2	48	0,8	78	3,0	78	3,0	127	3,2
5,00	17	0,2	43	0,7	70	2,4	70	2,4	114	2,6
6,00	14	0,1	36	0,5	58	1,7	58	1,7	95	1,8
7,00	12	0,1	31	0,3	50	1,2	50	1,2	82	1,3
8,00	10	0,1	27	0,3	44	0,9	44	0,9	72	1,0

Design notes Open Profiles

- Where applicable recommended values consider partial safety factors for actions and resistance
- Recommended stress (σ_{rec}) is determined using $\sigma_{\text{rec}} = (f_{y,d}) / ((\gamma_{\text{M1}}) \times (\gamma_{\text{M2}}))$ where
 - $f_{y,d}$ average yield strength (EN 1993-1-3:2024)
 - $\gamma_{\text{M1}} = 1,1$ partial Safety Factor for global buckling (DIN EN 1993-1-3:2006)
 - $\gamma_{\text{M2}} = 1,4$ partial Safety Factor for action loading

Selection example:

- 1,0 kN (≈ 100 kg) should be carried by a channel with a channel span width L = 100cm (single span simply supported).

Solution:

- Select the line with the load, F = 1,0 kN.
- The channels MT-20, MT-40 T up to MT-100 can be used because the recommended span width (table value) is larger or equal to the required span width of L = 100cm.

For further details behind calculations using this design method, please consult a Hilti engineer.

Technical Data for MT Profiles

(max. span width/deflection - point load in the middle of span)

Open C-channels

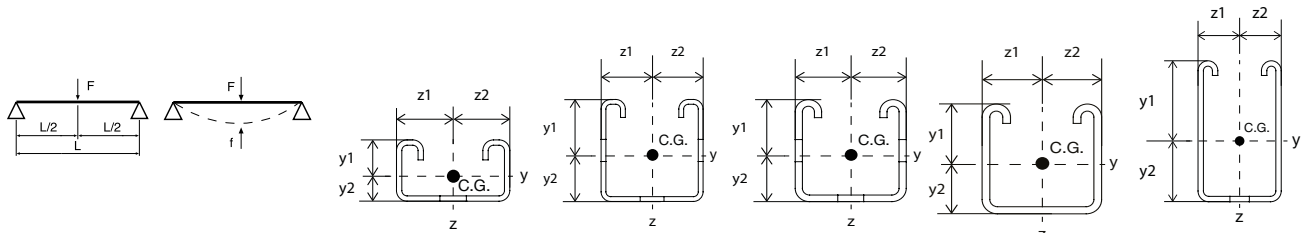

Max, span width L [cm] / deflection f [mm] - Result

load F [kN]	MT-30/ MT-30 OC		MT-40 V2/ MT-40 V2 OC		MT-50/ MT-50 OC		MT-50 U/ MT-50 U OC		MT-60/ MT-60 OC	
	L	f	L	f	L	f	L	f	L	f
0,25	174	11,5	348	23,1	386	25,6	386	25,6	600	30,1
0,50	126	8,4	255	17,0	293	19,5	293	19,5	548	36,4
0,75	103	6,8	210	13,9	244	16,2	244	16,2	470	31,3
1,00	83	4,6	183	12,2	213	14,1	213	14,1	416	27,6
1,25	66	3,0	164	10,9	191	12,6	191	12,6	377	25,0
1,50	55	2,1	142	8,4	175	11,6	175	11,6	347	23,0
1,75	47	1,5	122	6,2	163	10,9	163	10,9	317	20,2
2,00	41	1,2	107	4,8	152	10,0	152	10,0	279	15,7
2,25	37	0,9	95	3,8	144	9,6	144	9,6	250	12,5
2,50	33	0,7	85	3,1	136	8,9	136	8,9	226	10,2
2,75	30	0,6	78	2,5	127	7,9	127	7,9	206	8,5
3,00	28	0,5	71	2,1	116	6,7	116	6,7	189	7,1
3,50	24	0,4	61	1,6	100	4,9	100	4,9	163	5,3
4,00	21	0,3	54	1,2	87	3,8	87	3,8	143	4,1
4,50	18	0,2	48	0,9	78	3,0	78	3,0	127	3,2
5,00	17	0,2	43	0,8	70	2,4	70	2,4	114	2,6
6,00	14	0,1	36	0,5	58	1,7	58	1,7	95	1,8
7,00	12	0,1	31	0,4	50	1,2	50	1,2	82	1,3
8,00	10	0,1	27	0,3	44	0,9	44	0,9	72	1,0

Design notes Open Profiles

- Where applicable recommended values consider partial safety factors for actions and resistance
- Recommended stress (σ_{rec}) is determined using $\sigma_{\text{rec}} = (f_{yM}) / ((V_{yM}) \times (V_{yM}))$ where
 - f_{yM} average yield strength (EN 1993-1-3:2024)
 - $V_{yM} = 1,1$ partial Safety Factor for global buckling (DIN EN 1993-1-3:2006)
 - $V_{yM} = 1,4$ partial Safety Factor for action loading

Selection example:

- 1,0 kN (\approx 100 kg) should be carried by a channel with a channel span width L = 100cm (single span simply supported).

Solution:

- Select the line with the load, F = 1,0 kN.
- The channels MT-20, MT-40 T up to MT-100 can be used because the recommended span width (table value) is larger or equal to the required span width of L = 100cm.

For further details behind calculations using this design method, please consult a Hilti engineer.

Technical Data for MT Profiles

(max. span width/deflection - point load in the middle of span)

double channels

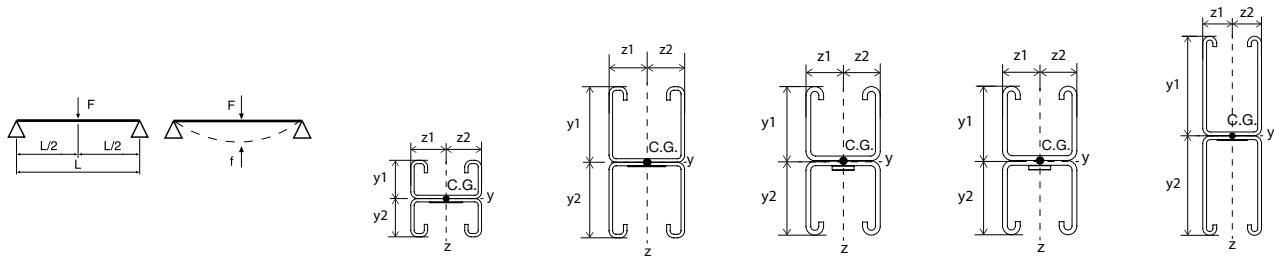

Max. span width L [cm] / deflection f [mm] - Result

load F [kN]	MT-30D/ MT-30D OC		MT-40D/ MT-40D OC		MT-50 D		MT-50D U		MT-60D/ MT-60D OC	
	L	f	L	f	L	f	L	f	L	f
0,25	377	25,1	600	25,8	600	22,8	600	22,8	600	6,5
0,50	287	19,1	590	39,2	600	35,3	600	35,3	600	9,4
0,75	239	15,9	508	33,7	553	36,8	553	36,8	600	12,3
1,00	209	13,9	452	30,1	496	33,0	496	33,0	600	15,3
1,25	188	12,5	410	27,2	452	30,0	452	30,0	600	18,2
1,50	159	9,1	378	25,1	418	27,8	418	27,8	600	21,1
1,75	137	6,7	352	23,3	391	26,1	391	26,1	600	24,1
2,00	120	5,2	314	18,8	368	24,5	368	24,5	600	27,0
2,25	107	4,1	281	15,0	348	23,1	348	23,1	600	30,0
2,50	97	3,3	254	12,3	332	22,1	332	22,1	600	32,9
2,75	88	2,8	232	10,2	317	21,1	317	21,1	600	35,8
3,00	81	2,3	213	8,6	304	20,2	304	20,2	600	38,8
3,50	69	1,7	184	6,4	283	18,9	283	18,9	557	35,5
4,00	61	1,3	161	4,9	265	17,6	265	17,6	494	27,8
4,50	54	1,0	143	3,9	250	16,6	250	16,6	443	22,4
5,00	49	0,8	129	3,2	228	14,0	228	14,0	402	18,3
6,00	40	0,6	108	2,2	191	9,8	191	9,8	338	13,0
7,00	35	0,4	93	1,6	164	7,2	164	7,2	291	9,6
8,00	30	0,3	81	1,2	144	5,5	144	5,5	256	7,4

Design notes Open Profiles

- Where applicable recommended values consider partial safety factors for actions and resistance
- Recommended stress (σ_{rec}) is determined using $\sigma_{rec} = (f_{yd} / [(Y_{plm}) \times (Y_m)])$ where
 - f_{yd} average yield strength (EN 1993-1-3:2024)
 - $Y_m = 1,1$ partial Safety Factor for global buckling (DIN EN 1993-1-3:2006)
 - $Y_{plm} = 1,4$ partial Safety Factor for action loading

Selection example:

- 1,0 kN (\approx 100 kg) should be carried by a channel with a channel span width $L = 100$ cm (single span simply supported).

Solution:

- Select the line with the load, $F = 1,0$ kN.
- The channels MT-20, MT-40 T up to MT-100 can be used because the recommended span width (table value) is larger or equal to the required span width of $L = 100$ cm.

For further details behind calculations using this design method, please consult a Hilti engineer.

Technical Data for MT Profiles

(max. span width/deflection - point load in the middle of span)

double channels

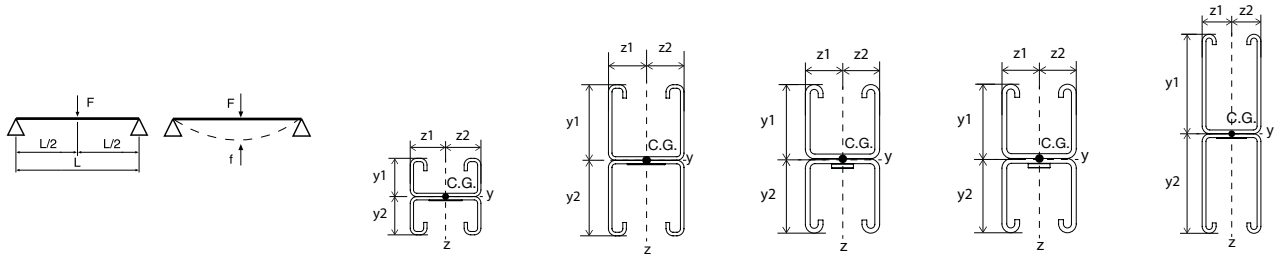

Max. span width L [cm] / deflection f [mm] - Result

load F [kN]	MT-30D/ MT-30D OC		MT-40D V2/ MT-40D V2 OC		MT-50 D		MT-50D U		MT-60D/ MT-60D OC	
	L	f	L	f	L	f	L	f	L	f
0,25	377	25,1	600	26,4	600	22,8	600	22,8	600	6,5
0,50	287	19,1	570	37,9	600	35,3	600	35,3	600	9,4
0,75	239	15,9	484	32,2	553	36,8	553	36,8	600	12,3
1,00	209	13,9	427	28,4	496	33,0	496	33,0	600	15,3
1,25	188	12,5	386	25,7	452	30,0	452	30,0	600	18,2
1,50	159	9,1	355	23,6	418	27,8	418	27,8	600	21,1
1,75	137	6,7	330	22,0	391	26,1	391	26,1	600	24,1
2,00	120	5,2	309	20,5	368	24,5	368	24,5	600	27,0
2,25	107	4,1	292	19,4	348	23,1	348	23,1	600	30,0
2,50	97	3,3	274	17,8	332	22,1	332	22,1	600	32,9
2,75	88	2,8	250	14,7	317	21,1	317	21,1	600	35,8
3,00	81	2,3	230	12,4	304	20,2	304	20,2	600	38,8
3,50	69	1,7	197	9,2	283	18,9	283	18,9	557	35,5
4,00	61	1,3	173	7,1	265	17,6	265	17,6	494	27,8
4,50	54	1,0	154	5,6	250	16,6	250	16,6	443	22,4
5,00	49	0,8	139	4,5	228	14,0	228	14,0	402	18,3
6,00	40	0,6	116	3,2	191	9,8	191	9,8	338	13,0
7,00	35	0,4	99	2,3	164	7,2	164	7,2	291	9,6
8,00	30	0,3	87	1,8	144	5,5	144	5,5	256	7,4

Design notes Open Profiles

- Where applicable recommended values consider partial safety factors for actions and resistance
- Recommended stress (σ_{red}) is determined using $\sigma_{\text{red}} = (f_{y0} / [(Y_{\text{Hilti}}) \times (Y_{\text{m}})])$ where
 - f_{y0} average yield strength (EN 1993-1-3:2024)
 - $Y_{\text{m}} = 1,1$ partial Safety Factor for global buckling (DIN EN 1993-1-3:2006)
 - $Y_{\text{Hilti}} = 1,4$ partial Safety Factor for action loading

Selection example:

- 1,0 kN (≈ 100 kg) should be carried by a channel with a channel span width $L = 100$ cm (single span simply supported).

Solution:

- Select the line with the load, $F = 1,0$ kN.
- The channels MT-20, MT-40 T up to MT-100 can be used because the recommended span width (table value) is larger or equal to the required span width of $L = 100$ cm.

For further details behind calculations using this design method, please consult a Hilti engineer.

Technical Data for MT Profiles

(max. span width/deflection - point load in the middle of span)

Box Profiles

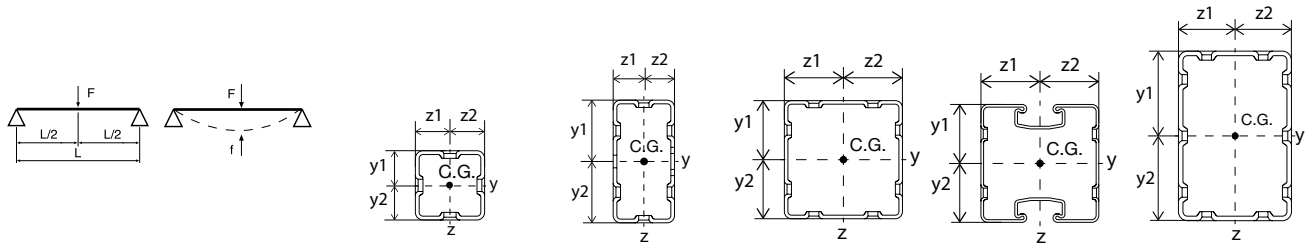

Max. span width L [cm] / deflection f [mm] - Result

load F [kN]	MT-70 OC		MT-80 OC		MT-90 OC		MT-90H OC		MT-100 OC	
	L	f	L	f	L	f	L	f	L	f
0,25	530	35,3	600	11,6	600	8,3	600	7,9	600	3,6
0,50	420	27,9	600	17,7	600	11,9	600	11,3	600	4,7
0,75	356	23,6	600	23,8	600	15,4	600	14,7	600	5,8
1,00	314	20,8	600	29,9	600	19,0	600	18,1	600	6,9
1,25	284	18,9	600	36,0	600	22,5	600	21,5	600	8,0
1,50	261	17,4	586	39,0	600	26,1	600	24,9	600	9,1
1,75	242	16,0	549	36,5	600	29,6	600	28,3	600	10,2
2,00	227	15,0	518	34,4	600	33,2	600	31,7	600	11,3
2,25	215	14,3	492	32,7	600	36,7	600	35,1	600	12,4
2,50	204	13,5	469	31,1	597	39,7	600	38,5	600	13,5
2,75	195	13,0	449	29,8	574	38,2	587	39,1	600	14,6
3,00	187	12,4	432	28,7	553	36,8	565	37,7	600	15,7
3,50	173	11,5	402	26,7	517	34,4	528	35,2	600	17,9
4,00	162	10,7	377	25,0	487	32,5	497	33,1	600	20,1
4,50	153	10,2	357	23,8	461	30,7	471	31,4	600	22,3
5,00	141	8,8	339	22,5	439	29,2	448	29,8	600	24,5
6,00	118	6,1	310	20,5	403	26,8	412	27,5	600	28,9
7,00	101	4,5	278	17,2	374	24,8	382	25,3	600	33,3
8,00	88	3,5	244	13,2	351	23,3	359	23,9	600	37,7

Design notes Box Profiles

- Where applicable recommended values consider partial safety factors for actions and resistance
- Recommended stress (σ_{rec}) is determined using $\sigma_{rec} = (f_y) / [(Y_{m1}) \times (Y_{m2})]$ where f_y yield strength (EN 1993-1-1:2022)
- $Y_{m1} = 1,0$ (MT-80, MT-90, MT-100); $1,1$ (MT-70, MT-90H) partial Safety Factor for cross-sections (EN 1993-1-1:2022)
- $Y_{m2} = 1,4$ (MT-70); $1,5$ (MT-80, MT-90, MT-90H, MT-100) partial Safety Factor for action loading

For further details behind calculations using this design method, please consult a Hilti engineer.

Technical Data for MT Profiles

(max. span width/deflection - **distributed load along the span**)

Trapeze Profiles

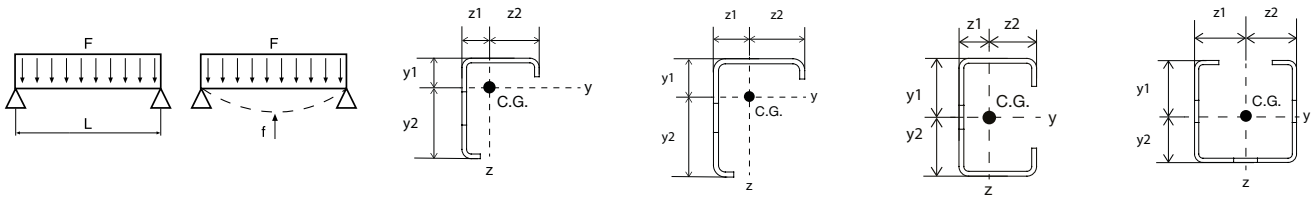

Max. span width L [cm] / deflection f [mm] - Result

load F [kN]	MT-10		MT-15/ MT-15 OC		MT-20/ MT-20 OC		MT-40 T/ MT-40 T OC	
	L	f	L	f	L	f	L	f
0,25	113	5,7	226	15,0	363	24,1	404	26,9
0,50	57	1,5	132	5,7	270	17,9	306	20,3
0,75	38	0,7	89	2,6	224	14,9	256	17,1
1,00	29	0,4	67	1,5	195	12,9	223	14,8
1,25	23	0,2	54	0,9	175	11,6	201	13,4
1,50	19	0,2	45	0,7	160	10,6	184	12,2
1,75	16	0,1	38	0,5	148	9,7	170	11,2
2,00	14	0,1	34	0,4	139	9,2	160	10,6
2,25	13	0,1	30	0,3	125	7,6	148	9,5
2,50	12	0,1	27	0,2	113	6,2	134	7,7
2,75	10	0,0	24	0,2	103	5,1	122	6,4
3,00	10	0,0	22	0,2	94	4,3	112	5,4
3,50	8	0,0	19	0,1	81	3,2	96	4,0
4,00	7	0,0	17	0,1	71	2,4	84	3,0
4,50	6	0,0	15	0,1	63	1,9	75	2,4
5,00	6	0,0	13	0,1	57	1,6	67	2,0
6,00	5	0,0	11	0,0	47	1,1	56	1,4
7,00	4	0,0	10	0,0	41	0,8	48	1,0
8,00	4	0,0	8	0,0	36	0,6	42	0,8

Design notes Open Profiles

- Where applicable recommended values consider partial safety factors for actions and resistance
- Recommended stress (σ_{rec}) is determined using $\sigma_{rec} = (f_{yd}) / ((\gamma_{M1}) \times (\gamma_{M2}))$ where
 - f_{yd} average yield strength (EN 1993-1-3:2024)
 - $\gamma_{M1} = 1,1$ partial Safety Factor for global buckling (DIN EN 1993-1-3:2006)
 - $\gamma_{M2} = 1,4$ partial Safety Factor for action loading

For further details behind calculations using this design method, please consult a Hilti engineer.

Technical Data for MT Profiles

(max. span width/deflection - **distributed load along the span**)

Open C-channels

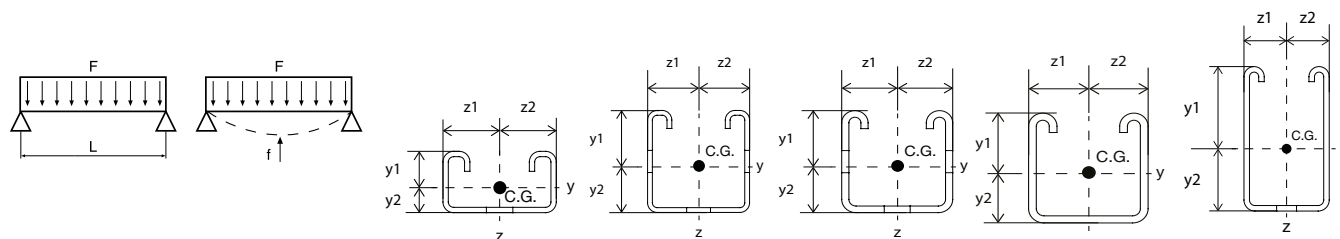

Max. span width L [cm] / deflection f [mm] - Result

load F [kN]	MT-30/ MT-30 OC		MT-40/ MT-40 OC		MT-50/ MT-50 OC		MT-50 U/ MT-50 U OC		MT-60/ MT-60 OC	
	L	f	L	f	L	f	L	f	L	f
0,25	214	14,2	428	28,4	450	30,0	450	30,0	600	23,0
0,50	157	10,4	330	21,9	355	23,5	355	23,5	600	34,7
0,75	130	8,7	277	18,4	301	20,0	301	20,0	561	37,4
1,00	113	7,5	243	16,2	265	17,6	265	17,6	505	33,6
1,25	101	6,7	218	14,4	239	15,8	239	15,8	462	30,7
1,50	92	6,0	200	13,2	220	14,6	220	14,6	428	28,5
1,75	85	5,5	186	12,4	204	13,5	204	13,5	400	26,5
2,00	80	5,3	174	11,5	191	12,6	191	12,6	377	25,0
2,25	73	4,6	164	10,8	181	12,0	181	12,0	358	23,8
2,50	66	3,7	156	10,3	172	11,4	172	11,4	341	22,7
2,75	60	3,1	149	9,9	164	10,9	164	10,9	326	21,7
3,00	55	2,6	142	9,2	157	10,4	157	10,4	313	20,8
3,50	47	1,9	122	6,8	146	9,7	146	9,7	291	19,3
4,00	41	1,5	107	5,2	136	8,9	136	8,9	273	18,1
4,50	37	1,2	95	4,2	129	8,6	129	8,6	250	15,5
5,00	33	0,9	86	3,4	122	8,1	122	8,1	226	12,7
6,00	28	0,7	71	2,3	112	7,5	112	7,5	189	8,9
7,00	24	0,5	61	1,7	100	6,1	100	6,1	163	6,6
8,00	21	0,4	54	1,3	87	4,7	87	4,7	143	5,1

Design notes Open Profiles

- Where applicable recommended values consider partial safety factors for actions and resistance
- Recommended stress (σ_{red}) is determined using $\sigma_{\text{red}} = (f_{y0}) / [(Y_{\text{red}}) \times (Y_{\text{m}})]$ where

f_{y0} average yield strength (EN 1993-1-3:2024)
 $Y_{\text{m}} = 1,1$ partial Safety Factor for global buckling (DIN EN 1993-1-3:2006)
 $Y_{\text{Hilti}} = 1,4$ partial Safety Factor for action loading

For further details behind calculations using this design method, please consult a Hilti engineer.

Technical Data for MT Profiles

(max. span width/deflection - **distributed load along the span**)

Open C-channels

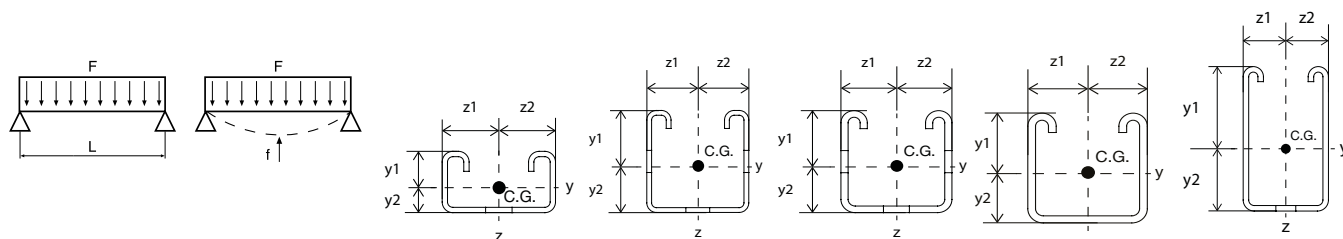

Max. span width L [cm] / deflection f [mm] - Result

load F [kN]	MT-30/ MT-30 OC		MT-40 V2/ MT-40 V2 OC		MT-50/ MT-50 OC		MT-50 U/ MT-50 U OC		MT-60/ MT-60 OC	
	L	f	L	f	L	f	L	f	L	f
0,25	214	14,2	418	27,9	450	30,0	450	30,0	600	23,0
0,50	157	10,4	315	20,9	355	23,5	355	23,5	600	34,7
0,75	130	8,7	263	17,5	301	20,0	301	20,0	561	37,4
1,00	113	7,5	229	15,2	265	17,6	265	17,6	505	33,6
1,25	101	6,7	206	13,7	239	15,8	239	15,8	462	30,7
1,50	92	6,0	189	12,6	220	14,6	220	14,6	428	28,5
1,75	85	5,5	175	11,6	204	13,5	204	13,5	400	26,5
2,00	80	5,3	164	10,9	191	12,6	191	12,6	377	25,0
2,25	73	4,6	155	10,3	181	12,0	181	12,0	358	23,8
2,50	66	3,7	147	9,8	172	11,4	172	11,4	341	22,7
2,75	60	3,1	140	9,3	164	10,9	164	10,9	326	21,7
3,00	55	2,6	134	8,9	157	10,4	157	10,4	313	20,8
3,50	47	1,9	122	7,8	146	9,7	146	9,7	291	19,3
4,00	41	1,5	107	6,0	136	8,9	136	8,9	273	18,1
4,50	37	1,2	95	4,7	129	8,6	129	8,6	250	15,5
5,00	33	0,9	85	3,8	122	8,1	122	8,1	226	12,7
6,00	28	0,7	71	2,7	112	7,5	112	7,5	189	8,9
7,00	24	0,5	61	2,0	100	6,1	100	6,1	163	6,6
8,00	21	0,4	54	1,5	87	4,7	87	4,7	143	5,1

Design notes Open Profiles

• Where applicable recommended values consider partial safety factors for actions and resistance

• Recommended stress (σ_{rec}) is determined using $\sigma_{rec} = (f_{yd}) / (\gamma_{M1}) \times (\gamma_{M2})$ where

f_{yd} average yield strength (EN 1993-1-3:2024)

$\gamma_{M1} = 1,1$ partial Safety Factor for global buckling (DIN EN 1993-1-3:2006)

$\gamma_{M2} = 1,4$ partial Safety Factor for action loading

For further details behind calculations using this design method, please consult a Hilti engineer.

Technical Data for MT Profiles

(max. span width/deflection - **distributed load along the span**)

double channels

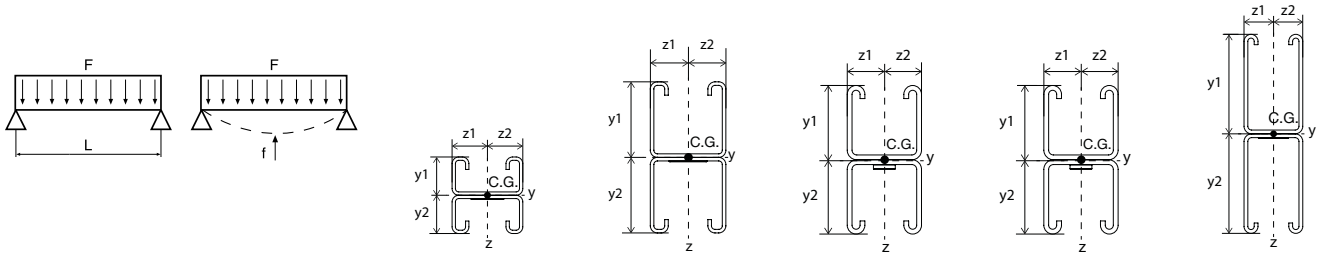

Max. span width L [cm] / deflection f [mm] - Result

load F [kN]	MT-30D/ MT-30D OC		MT-40D/ MT-40D OC		MT-50 D		MT-50D U		MT-60D/ MT-60D OC	
	L	f	L	f	L	f	L	f	L	f
0,25	438	29,2	600	19,9	600	18,1	600	18,1	600	5,4
0,50	347	23,0	600	29,7	600	25,9	600	25,9	600	7,2
0,75	295	19,7	600	39,5	600	33,7	600	33,7	600	9,0
1,00	259	17,1	545	36,2	590	39,3	590	39,3	600	10,9
1,25	235	15,7	500	33,2	545	36,3	545	36,3	600	12,7
1,50	215	14,2	465	31,0	509	33,9	509	33,9	600	14,5
1,75	200	13,2	435	28,9	478	31,8	478	31,8	600	16,4
2,00	188	12,5	410	27,2	452	30,0	452	30,0	600	18,2
2,25	177	11,7	389	25,8	430	28,6	430	28,6	600	20,0
2,50	169	11,3	371	24,6	411	27,4	411	27,4	600	21,9
2,75	161	10,7	355	23,6	394	26,2	394	26,2	600	23,7
3,00	154	10,2	341	22,6	379	25,3	379	25,3	600	25,6
3,50	137	8,4	317	21,0	353	23,5	353	23,5	600	29,2
4,00	120	6,4	298	19,8	332	22,1	332	22,1	600	32,9
4,50	107	5,1	281	18,7	314	20,9	314	20,9	600	36,6
5,00	97	4,1	254	15,3	298	19,8	298	19,8	598	39,8
6,00	81	2,9	213	10,7	273	18,1	273	18,1	551	36,6
7,00	69	2,1	184	8,0	254	16,9	254	16,9	514	34,2
8,00	61	1,6	161	6,1	238	15,8	238	15,8	483	32,1

Design notes Open Profiles

- Where applicable recommended values consider partial safety factors for actions and resistance
- Recommended stress (σ_{rec}) is determined using $\sigma_{rec} = (f_{y,a}) / ((\gamma_{m,1}) \times (\gamma_{a}))$ where
 - $f_{y,a}$ average yield strength (EN 1993-1-3:2024)
 - $\gamma_{m,1} = 1,1$ partial Safety Factor for global buckling (DIN EN 1993-1-3:2006)
 - $\gamma_{a} = 1,4$ partial Safety Factor for action loading

For further details behind calculations using this design method, please consult a Hilti engineer.

Technical Data for MT Profiles

(max. span width/deflection - **distributed load along the span**)

double channels

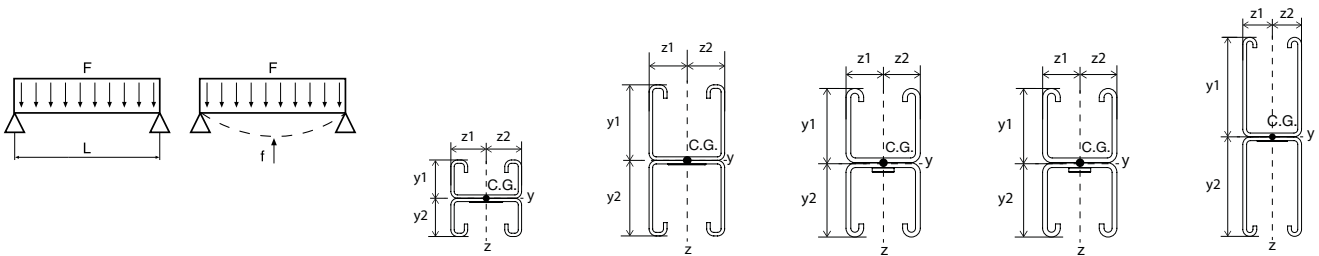

Max. span width L [cm] / deflection f [mm] - Result

load F [kN]	MT-30D/ MT-30D OC		MT-40D V2/ MT-40D V2 OC		MT-50 D		MT-50D U		MT-60D/ MT-60D OC	
	L	f	L	f	L	f	L	f	L	f
0,25	438	29,2	600	19,6	600	18,1	600	18,1	600	5,4
0,50	347	23,0	600	31,0	600	25,9	600	25,9	600	7,2
0,75	295	19,7	584	38,9	600	33,7	600	33,7	600	9,0
1,00	259	17,1	522	34,7	590	39,3	590	39,3	600	10,9
1,25	235	15,7	476	31,7	545	36,3	545	36,3	600	12,7
1,50	215	14,2	440	29,3	509	33,9	509	33,9	600	14,5
1,75	200	13,2	410	27,2	478	31,8	478	31,8	600	16,4
2,00	188	12,5	386	25,7	452	30,0	452	30,0	600	18,2
2,25	177	11,7	366	24,4	430	28,6	430	28,6	600	20,0
2,50	169	11,3	348	23,1	411	27,4	411	27,4	600	21,9
2,75	161	10,7	333	22,2	394	26,2	394	26,2	600	23,7
3,00	154	10,2	319	21,2	379	25,3	379	25,3	600	25,6
3,50	137	8,4	296	19,6	353	23,5	353	23,5	600	29,2
4,00	120	6,4	278	18,5	332	22,1	332	22,1	600	32,9
4,50	107	5,1	262	17,4	314	20,9	314	20,9	600	36,6
5,00	97	4,1	249	16,5	298	19,8	298	19,8	598	39,8
6,00	81	2,9	228	15,2	273	18,1	273	18,1	551	36,6
7,00	69	2,1	197	11,5	254	16,9	254	16,9	514	34,2
8,00	61	1,6	173	8,8	238	15,8	238	15,8	483	32,1

Design notes Open Profiles

- Where applicable recommended values consider partial safety factors for actions and resistance
- Recommended stress (σ_{rec}) is determined using $\sigma_{\text{rec}} = (f_{y0}) / ((\gamma_{\text{min}}) \times (\gamma_{\text{act}}))$ where
 - f_{y0} average yield strength (EN 1993-1-3:2024)
 - $\gamma_{\text{min}} = 1,1$ partial Safety Factor for global buckling (DIN EN 1993-1-3:2006)
 - $\gamma_{\text{HilTI}} = 1,4$ partial Safety Factor for action loading

For further details behind calculations using this design method, please consult a Hilti engineer.

Technical Data for MT Profiles

(max. span width/deflection - **distributed load along the span**)

Box Profiles

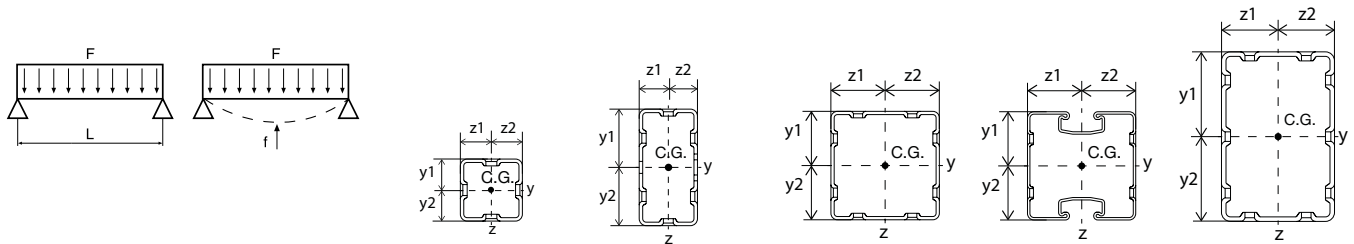

Max. span width L [cm] / deflection f [mm] - Result

load F [kN]	MT-70 OC		MT-80 OC		MT-90 OC		MT-90H OC		MT-100 OC	
	L	f	L	f	L	f	L	f	L	f
0,25	594	39,5	600	9,3	600	7,0	600	6,6	600	3,2
0,50	495	32,9	600	13,1	600	9,2	600	8,7	600	3,9
0,75	431	28,7	600	16,9	600	11,4	600	10,9	600	4,6
1,00	385	25,6	600	20,7	600	13,7	600	13,0	600	5,2
1,25	350	23,2	600	24,5	600	15,9	600	15,1	600	5,9
1,50	323	21,4	600	28,4	600	18,1	600	17,3	600	6,6
1,75	302	20,1	600	32,2	600	20,3	600	19,4	600	7,3
2,00	284	18,9	600	36,0	600	22,5	600	21,5	600	8,0
2,25	269	17,9	600	39,8	600	24,8	600	23,6	600	8,7
2,50	256	17,0	576	38,3	600	27,0	600	25,8	600	9,4
2,75	244	16,1	553	36,7	600	29,2	600	27,9	600	10,0
3,00	234	15,5	533	35,4	600	31,4	600	30,0	600	10,7
3,50	218	14,5	498	33,1	600	35,9	600	34,3	600	12,1
4,00	204	13,5	469	31,1	597	39,7	600	38,5	600	13,5
4,50	193	12,8	445	29,6	568	37,7	580	38,5	600	14,9
5,00	183	12,1	424	28,2	543	36,1	555	37,0	600	16,2
6,00	167	11,0	389	25,9	501	33,3	512	34,1	600	19,0
7,00	155	10,3	361	23,9	467	31,1	477	31,7	600	21,7
8,00	145	9,6	339	22,5	439	29,2	448	29,8	600	24,5

Design notes Box Profiles

- Where applicable recommended values consider partial safety factors for actions and resistance
- Recommended stress (σ_{rec}) is determined using $\sigma_{rec} = (f_y) / [(Y_{m,red}) \times (Y_{a,red})]$ where f_y yield strength (EN 1993-1-1:2022)
- $Y_{m} = 1,0$ (MT-80, MT-90, MT-100); $1,1$ (MT-70, MT-90H) partial Safety Factor for cross-sections (EN 1993-1-1:2022)
- $Y_{a,HilTI} = 1,4$ (MT-70); $1,5$ (MT-80, MT-90, MT-90H, MT-100) partial Safety Factor for action loading

For further details behind calculations using this design method, please consult a Hilti engineer.

Technical Data for MT Profiles

(max. span width/deflection - point load in the middle of span)

Trapeze Profiles

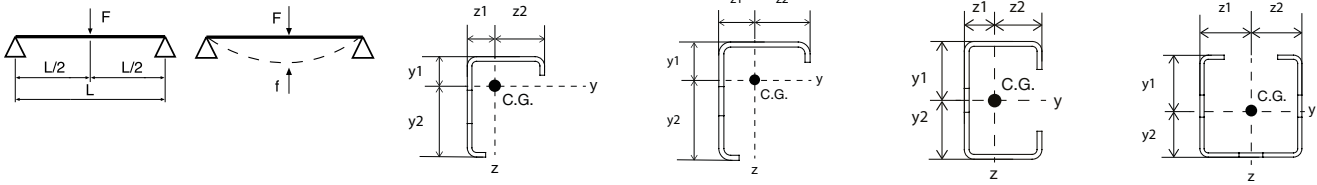

Max. load F [kN] / deflection f [mm] - Result

span width L [cm]	MT-10		MT-15/ MT-15 OC		MT-20/ MT-20 OC		MT-40 T/ MT-40 T OC	
	F	f	F	f	F	f	F	f
25	0,58	0,2	1,34	0,2	5,69	0,2	6,74	0,2
50	0,29	0,9	0,67	0,7	2,84	1,0	3,36	0,9
75	0,19	2,0	0,45	1,5	1,89	2,2	2,24	1,9
100	0,14	3,5	0,33	2,6	1,42	3,9	1,68	3,5
125	0,11	5,6	0,26	4,1	1,13	6,1	1,34	5,4
150	0,09	8,0	0,22	6,0	0,94	8,7	1,11	7,8
175	0,08	10,9	0,19	8,1	0,79	11,6	0,95	10,6
200	0,06	13,2	0,16	10,6	0,60	13,3	0,79	13,3
225	0,05	14,8	0,14	13,5	0,46	14,9	0,62	14,9
250	0,04	16,4	0,12	16,5	0,37	16,6	0,49	16,6
275	0,03	18,0	0,10	18,1	0,30	18,2	0,40	18,2
300	0,02	19,5	0,08	19,7	0,25	19,8	0,33	19,8
325	0,02	21,0	0,07	21,3	0,20	21,4	0,27	21,4
350	0,01	22,4	0,05	22,8	0,17	23,0	0,22	23,0
375	0,01	23,8	0,04	24,3	0,14	24,6	0,19	24,6
400	0,01	25,1	0,03	25,8	0,12	26,1	0,16	26,1
425			0,03	27,2	0,10	27,6	0,13	27,6
450			0,02	28,6	0,08	29,1	0,11	29,1
475			0,02	29,9	0,07	30,5	0,09	30,5
500			0,01	31,2	0,05	31,9	0,07	31,9
525			0,01	32,4	0,04	33,3	0,06	33,3
550					0,03	34,6	0,04	34,6
575					0,02	35,9	0,03	35,9
600					0,02	37,1	0,02	37,1

Design notes Open Profiles

- Where applicable recommended values consider partial safety factors for actions and resistance
- Recommended stress (σ_{rec}) is determined using $\sigma_{\text{rec}} = (f_{y0}) / ([\gamma_{\text{M1}}] \times [\gamma_{\text{M2}}])$ where
 - f_{y0} average yield strength (EN 1993-1-3:2024)
 - $\gamma_{\text{M1}} = 1,1$ partial Safety Factor for global buckling (DIN EN 1993-1-3:2006)
 - $\gamma_{\text{M2}} = 1,4$ partial Safety Factor for action loading

For further details behind calculations using this design method, please consult a Hilti engineer.

Version from 03.2026

Technical Data for MT Profiles

(max. span width/deflection - point load in the middle of span)

Open C-channels

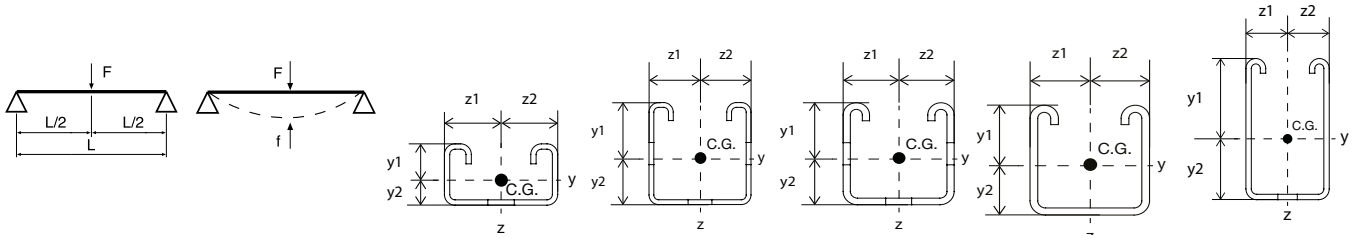

Max. load F [kN] / deflection f [mm] - Result

span width L [cm]	MT-30/ MT-30 OC		MT-40/ MT-40 OC		MT-50/ MT-50 OC		MT-50 U/ MT-50 U OC		MT-60/ MT-60 OC	
	F	f	F	f	F	f	F	f	F	f
25	3,32	0,4	8,58	0,2	14,01	0,3	14,01	0,3	22,96	0,1
50	1,66	1,7	4,29	0,9	7,00	1,2	7,00	1,2	11,47	0,5
75	1,10	3,8	2,85	2,1	4,66	2,8	4,66	2,8	7,64	1,1
100	0,80	6,7	2,14	3,7	3,49	4,9	3,49	4,9	5,72	2,0
125	0,51	8,3	1,70	5,8	2,79	7,7	2,79	7,7	4,57	3,1
150	0,35	10,0	1,41	8,3	2,07	10,0	2,07	10,0	3,80	4,5
175	0,25	11,6	1,21	11,3	1,51	11,6	1,51	11,6	3,25	6,1
200	0,18	13,2	0,94	13,3	1,14	13,3	1,14	13,3	2,83	8,0
225	0,14	14,8	0,73	14,9	0,89	14,9	0,89	14,9	2,51	10,1
250	0,10	16,4	0,59	16,6	0,71	16,6	0,71	16,6	2,25	12,5
275	0,08	17,9	0,47	18,2	0,57	18,2	0,57	18,2	2,03	15,2
300	0,06	19,4	0,39	19,8	0,47	19,8	0,47	19,8	1,85	18,1
325	0,04	20,8	0,32	21,4	0,39	21,4	0,39	21,4	1,70	21,3
350	0,03	22,2	0,27	23,0	0,32	23,0	0,32	23,0	1,47	23,2
375	0,02	23,4	0,22	24,6	0,27	24,5	0,27	24,5	1,26	24,8
400	0,01	24,6	0,19	26,1	0,22	26,0	0,22	26,0	1,09	26,4
425			0,15	27,6	0,18	27,5	0,18	27,5	0,95	28,0
450			0,13	29,1	0,15	29,0	0,15	29,0	0,82	29,6
475			0,11	30,5	0,12	30,4	0,12	30,4	0,72	31,2
500			0,08	31,9	0,09	31,8	0,09	31,8	0,63	32,8
525			0,07	33,3	0,07	33,1	0,07	33,1	0,55	34,3
550			0,05	34,6	0,05	34,4	0,05	34,4	0,48	35,8
575			0,04	35,9	0,03	35,6	0,03	35,6	0,42	37,3
600			0,02	37,1	0,02	36,8	0,02	36,8	0,37	38,8

Design notes Open Profiles

- Where applicable recommended values consider partial safety factors for actions and resistance
- Recommended stress (σ_{rec}) is determined using $\sigma_{rec} = (f_{ya}) / ((\gamma_{M1}) \times (\gamma_{a}))$ where
 - f_{ya} average yield strength (EN 1993-1-3:2024)
 - $\gamma_{M1} = 1,1$ partial Safety Factor for global buckling (DIN EN 1993-1-3:2006)
 - $\gamma_{M1} = 1,4$ partial Safety Factor for action loading

For further details behind calculations using this design method, please consult a Hilti engineer.

Technical Data for MT Profiles

(max. span width/deflection - point load in the middle of span)

Open C-channels

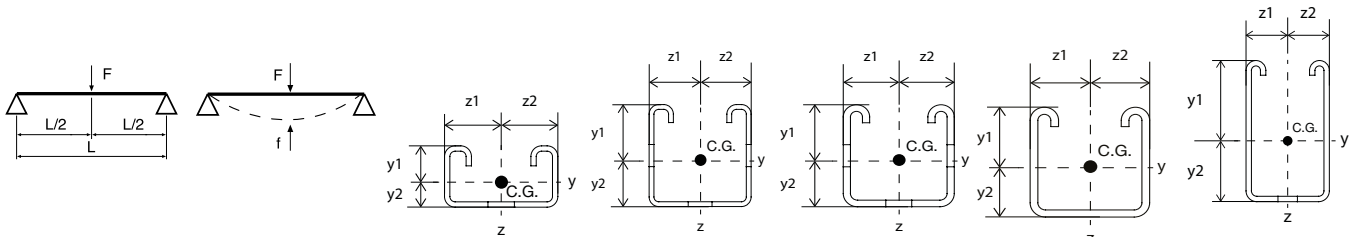

Max. load F [kN] / deflection f [mm] - Result

span width L [cm]	MT-30/ MT-30 OC		MT-40 V2/ MT-40 V2 OC		MT-50/ MT-50 OC		MT-50 U/ MT-50 U OC		MT-60/ MT-60 OC	
	F	f	F	f	F	f	F	f	F	f
25	3,32	0,4	8,57	0,3	14,01	0,3	14,01	0,3	22,96	0,1
50	1,66	1,7	4,28	1,0	7,00	1,2	7,00	1,2	11,47	0,5
75	1,10	3,8	2,85	2,4	4,66	2,8	4,66	2,8	7,64	1,1
100	0,80	6,7	2,14	4,2	3,49	4,9	3,49	4,9	5,72	2,0
125	0,51	8,3	1,70	6,5	2,79	7,7	2,79	7,7	4,57	3,1
150	0,35	10,0	1,42	9,4	2,07	10,0	2,07	10,0	3,80	4,5
175	0,25	11,6	1,10	11,6	1,51	11,6	1,51	11,6	3,25	6,1
200	0,18	13,2	0,83	13,3	1,14	13,3	1,14	13,3	2,83	8,0
225	0,14	14,8	0,65	15,0	0,89	14,9	0,89	14,9	2,51	10,1
250	0,10	16,4	0,52	16,6	0,71	16,6	0,71	16,6	2,25	12,5
275	0,08	17,9	0,42	18,2	0,57	18,2	0,57	18,2	2,03	15,2
300	0,06	19,4	0,35	19,8	0,47	19,8	0,47	19,8	1,85	18,1
325	0,04	20,8	0,29	21,5	0,39	21,4	0,39	21,4	1,70	21,3
350	0,03	22,2	0,24	23,0	0,32	23,0	0,32	23,0	1,47	23,2
375	0,02	23,4	0,20	24,6	0,27	24,5	0,27	24,5	1,26	24,8
400	0,01	24,6	0,17	26,2	0,22	26,0	0,22	26,0	1,09	26,4
425			0,15	27,7	0,18	27,5	0,18	27,5	0,95	28,0
450			0,12	29,2	0,15	29,0	0,15	29,0	0,82	29,6
475			0,10	30,7	0,12	30,4	0,12	30,4	0,72	31,2
500			0,08	32,1	0,09	31,8	0,09	31,8	0,63	32,8
525			0,07	33,6	0,07	33,1	0,07	33,1	0,55	34,3
550			0,06	34,9	0,05	34,4	0,05	34,4	0,48	35,8
575			0,04	36,3	0,03	35,6	0,03	35,6	0,42	37,3
600			0,03	37,5	0,02	36,8	0,02	36,8	0,37	38,8

Design notes Open Profiles

- Where applicable recommended values consider partial safety factors for actions and resistance
- Recommended stress (σ_{rec}) is determined using $\sigma_{rec} = (f_{yd}) / [(Y_{red}) \times (Y_{m})]$ where
 - f_{yd} average yield strength (EN 1993-1-3:2024)
 - $Y_{m} = 1,1$ partial Safety Factor for global buckling (DIN EN 1993-1-3:2006)
 - $Y_{red} = 1,4$ partial Safety Factor for action loading

For further details behind calculations using this design method, please consult a Hilti engineer.

Technical Data for MT Profiles

(max. span width/deflection - point load in the middle of span)

double channels

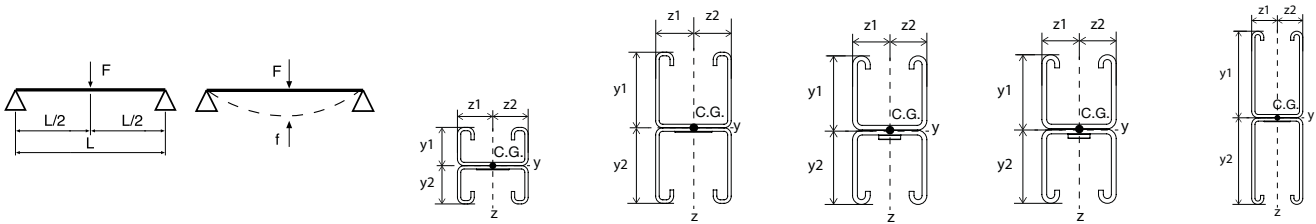

Max. load F [kN] / deflection f [mm] - Result

span width L [cm]	MT-30D/ MT-30D OC		MT-40D/ MT-40D OC		MT-50 D		MT-50D U		MT-60D/ MT-60D OC	
	F	f	F	f	F	f	F	f	F	f
25	9,71* **	0,2	26,00	0,1	41,91*	0,2	41,91*	0,2	82,95*	0,1
50	4,85	0,9	12,99	0,5	23,10	0,7	23,10	0,7	41,46*	0,3
75	3,23	2,0	8,65	1,1	15,39	1,5	15,39	1,5	27,62	0,6
100	2,41	3,6	6,48	1,9	11,53	2,7	11,53	2,7	20,70	1,1
125	1,93	5,6	5,17	3,0	9,21	4,2	9,21	4,2	16,54	1,8
150	1,60	8,0	4,30	4,3	7,66	6,0	7,66	6,0	13,77	2,5
175	1,36	10,9	3,68	5,8	6,55	8,2	6,55	8,2	11,78	3,5
200	1,10	13,3	3,21	7,6	5,72	10,7	5,72	10,7	10,29	4,5
225	0,85	14,9	2,84	9,6	5,07	13,6	5,07	13,6	9,13	5,7
250	0,68	16,6	2,55	11,9	4,52	16,6	4,52	16,6	8,20	7,1
275	0,55	18,2	2,30	14,4	3,71	18,3	3,71	18,3	7,43	8,6
300	0,45	19,8	2,10	17,1	3,09	19,9	3,09	19,9	6,79	10,2
325	0,36	21,4	1,93	20,1	2,61	21,6	2,61	21,6	6,25	12,0
350	0,30	22,9	1,77	23,2	2,22	23,2	2,22	23,2	5,79	13,9
375	0,25	24,4	1,52	24,8	1,91	24,8	1,91	24,8	5,38	16,0
400	0,20	25,9	1,32	26,5	1,65	26,5	1,65	26,5	5,02	18,2
425	0,17	27,4	1,15	28,1	1,43	28,1	1,43	28,1	4,71	20,5
450	0,13	28,8	1,00	29,7	1,25	29,7	1,25	29,7	4,43	23,1
475	0,10	30,2	0,88	31,3	1,10	31,2	1,10	31,2	4,18	25,7
500	0,08	31,6	0,77	32,8	0,96	32,8	0,96	32,8	3,95	28,5
525	0,06	32,9	0,68	34,4	0,85	34,4	0,85	34,4	3,74	31,5
550	0,04	34,1	0,60	35,9	0,74	35,9	0,74	35,9	3,55	34,6
575	0,02	35,3	0,52	37,5	0,65	37,4	0,65	37,4	3,38	37,9
600			0,46	39,0	0,57	38,9	0,57	38,9	3,07	39,6

Design notes Open Profiles

- Where applicable recommended values consider partial safety factors for actions and resistance
- Recommended stress (σ_{rec}) is determined using $\sigma_{rec} = (f_{yd}) / ((V_{Hilf}) \times (V_{m}))$ where
 - f_{yd} average yield strength (EN 1993-1-3:2024)
 - $V_{m} = 1,1$ partial Safety Factor for global buckling (DIN EN 1993-1-3:2006)
 - $V_{Hilf} = 1,4$ partial Safety Factor for action loading

* Span limited by shear flow resistance of back-to-back joints.

** Maximum load limited to 5.71kN due to back-to-back channel separation

For further details behind calculations using this design method, please consult a Hilti engineer.

Technical Data for MT Profiles

(max. span width/deflection - point load in the middle of span)

double channels

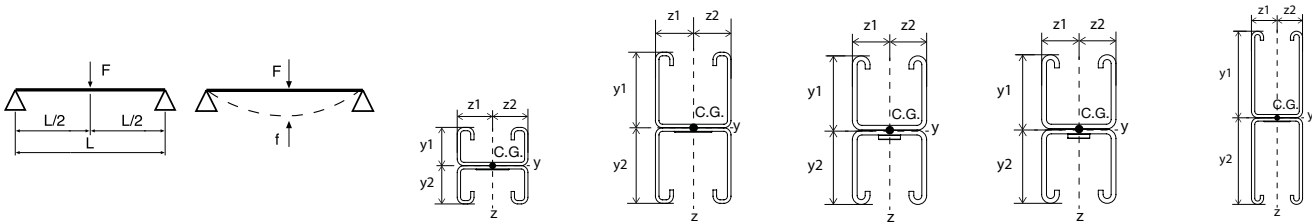

Max. load F [kN] / deflection f [mm] - Result

span width L [cm]	MT-30D/ MT-30D OC		MT-40D V2/ MT-40D V2 OC		MT-50 D		MT-50D U		MT-60D/ MT-60D OC	
	F	f	F	f	F	f	F	f	F	f
25	9,71* **	0,2	26,31	0,1	41,91*	0,2	41,91*	0,2	82,95*	0,1
50	4,85	0,9	13,93	0,6	23,10	0,7	23,10	0,7	41,46*	0,3
75	3,23	2,0	9,28	1,3	15,39	1,5	15,39	1,5	27,62	0,6
100	2,41	3,6	6,95	2,4	11,53	2,7	11,53	2,7	20,70	1,1
125	1,93	5,6	5,56	3,7	9,21	4,2	9,21	4,2	16,54	1,8
150	1,60	8,0	4,62	5,3	7,66	6,0	7,66	6,0	13,77	2,5
175	1,36	10,9	3,96	7,2	6,55	8,2	6,55	8,2	11,78	3,5
200	1,10	13,3	3,45	9,4	5,72	10,7	5,72	10,7	10,29	4,5
225	0,85	14,9	3,06	11,9	5,07	13,6	5,07	13,6	9,13	5,7
250	0,68	16,6	2,75	14,7	4,52	16,6	4,52	16,6	8,20	7,1
275	0,55	18,2	2,49	17,9	3,71	18,3	3,71	18,3	7,43	8,6
300	0,45	19,8	2,13	19,9	3,09	19,9	3,09	19,9	6,79	10,2
325	0,36	21,4	1,80	21,6	2,61	21,6	2,61	21,6	6,25	12,0
350	0,30	22,9	1,54	23,2	2,22	23,2	2,22	23,2	5,79	13,9
375	0,25	24,4	1,33	24,9	1,91	24,8	1,91	24,8	5,38	16,0
400	0,20	25,9	1,15	26,5	1,65	26,5	1,65	26,5	5,02	18,2
425	0,17	27,4	1,01	28,1	1,43	28,1	1,43	28,1	4,71	20,5
450	0,13	28,8	0,88	29,7	1,25	29,7	1,25	29,7	4,43	23,1
475	0,10	30,2	0,78	31,3	1,10	31,2	1,10	31,2	4,18	25,7
500	0,08	31,6	0,69	32,9	0,96	32,8	0,96	32,8	3,95	28,5
525	0,06	32,9	0,61	34,5	0,85	34,4	0,85	34,4	3,74	31,5
550	0,04	34,1	0,54	36,1	0,74	35,9	0,74	35,9	3,55	34,6
575	0,02	35,3	0,48	37,6	0,65	37,4	0,65	37,4	3,38	37,9
600			0,42	39,2	0,57	38,9	0,57	38,9	3,07	39,6

Design notes Open Profiles

- Where applicable recommended values consider partial safety factors for actions and resistance
- Recommended stress (σ_{rec}) is determined using $\sigma_{rec} = (f_{yk}) / ((\gamma_{M1}) \times (\gamma_{M2}))$ where
 - f_{yk} average yield strength (EN 1993-1-3:2024)
 - $\gamma_{M1} = 1,1$ partial Safety Factor for global buckling (DIN EN 1993-1-3:2006)
 - $\gamma_{M2} = 1,4$ partial Safety Factor for action loading

* Span limited by shear flow resistance of back-to-back joints.

** Maximum load limited to 5.71kN due to back-to-back channel separation

For further details behind calculations using this design method, please consult a Hilti engineer.

Technical Data for MT Profiles

(max. span width/deflection - point load in the middle of span)

Box Profiles

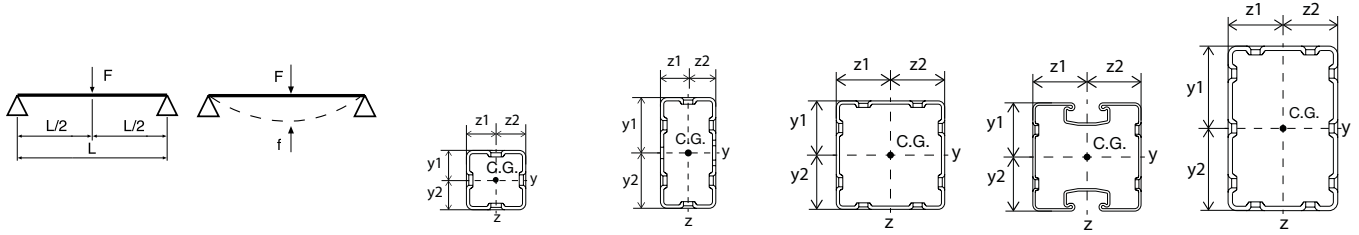

Max, load F [kN] / deflection f [mm] - Result

span width L [cm]	MT-70 OC		MT-80 OC		MT-90 OC		MT-90H OC		MT-100 OC	
	F	f	F	f	F	f	F	f	F	f
25	28,33	0,3	78,74	0,1	106,17	0,1	60,13	0,1	222,70	0,1
50	14,16	1,1	39,36	0,6	61,31	0,5	60,13	0,5	147,29	0,4
75	9,43	2,5	26,23	1,2	40,85	1,1	47,35	1,3	98,16	0,8
100	7,06	4,4	19,66	2,2	30,62	2,0	35,49	2,2	73,59	1,5
125	5,64	6,9	15,71	3,5	24,48	3,2	28,38	3,5	58,84	2,3
150	4,69	10,0	13,08	5,0	20,38	4,5	23,63	5,0	49,00	3,4
175	3,44	11,7	11,20	6,8	17,44	6,2	20,23	6,9	41,96	4,6
200	2,61	13,3	9,78	8,9	15,24	8,1	17,68	9,0	36,68	6,0
225	2,05	15,0	8,68	11,3	13,53	10,2	15,70	11,4	32,57	7,6
250	1,64	16,6	7,80	13,9	12,15	12,6	14,11	14,0	29,28	9,4
275	1,34	18,2	7,08	16,8	11,03	15,3	12,80	17,0	26,58	11,4
300	1,10	19,9	6,45	20,0	10,09	18,2	11,56	20,0	24,33	13,5
325	0,92	21,5	5,46	21,6	9,29	21,4	9,81	21,6	22,42	15,9
350	0,78	23,1	4,68	23,3	8,06	23,3	8,42	23,3	20,78	18,4
375	0,66	24,7	4,05	24,9	6,98	24,9	7,29	24,9	19,36	21,2
400	0,56	26,3	3,53	26,6	6,09	26,6	6,36	26,6	18,11	24,1
425	0,48	27,8	3,10	28,2	5,35	28,2	5,59	28,2	17,01	27,2
450	0,41	29,4	2,73	29,8	4,73	29,8	4,95	29,9	15,70	29,9
475	0,34	30,9	2,42	31,4	4,20	31,5	4,40	31,5	14,02	31,6
500	0,29	32,3	2,16	33,1	3,75	33,1	3,92	33,1	12,58	33,2
525	0,25	33,8	1,93	34,7	3,35	34,7	3,52	34,7	11,34	34,8
550	0,20	35,2	1,73	36,3	3,01	36,3	3,16	36,3	10,25	36,5
575	0,17	36,6	1,55	37,9	2,71	37,9	2,85	37,9	9,31	38,1
600	0,13	38,0	1,39	39,4	2,44	39,5	2,57	39,5	8,47	39,7

Design notes Box Profiles

- Where applicable recommended values consider partial safety factors for actions and resistance
- Recommended stress (σ_{rec}) is determined using $\sigma_{rec} = (f_y) / [(Y_{red}) \times (Y_{m})]$ where f_y yield strength (EN 1993-1-1:2022)
- $Y_m = 1,0$ (MT-80, MT-90, MT-100); $1,1$ (MT-70, MT-90H) partial Safety Factor for cross-sections (EN 1993-1-1:2022)
- $Y_{Hilti} = 1,4$ (MT-70); $1,5$ (MT-80, MT-90, MT-90H, MT-100) partial Safety Factor for action loading

For further details behind calculations using this design method, please consult a Hilti engineer.

Technical Data for MT Profiles

(max. span width/deflection - distributed load along the span)

Trapeze Profiles

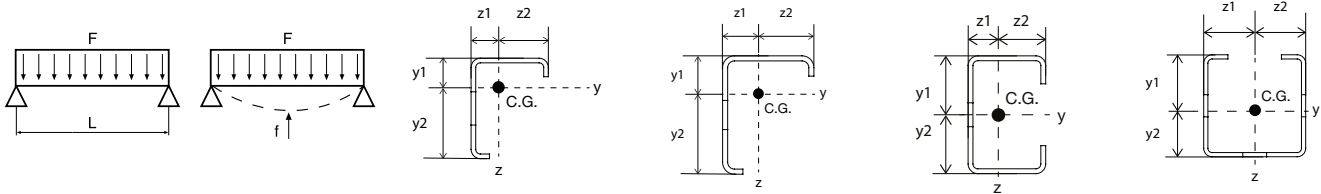

Max. span width L [cm] / deflection f [mm] - Result

span width L [cm]	MT-10		MT-15/ MT-15 OC		MT-20/ MT-20 OC		MT-40 T/ MT-40 T OC	
	F	f	F	f	F	f	F	f
25	1,15	0,3	2,69	0,2	8,65	0,2	13,47	0,3
50	0,58	1,1	1,34	0,8	5,68	1,2	6,73	1,1
75	0,38	2,5	0,89	1,9	3,78	2,7	4,48	2,4
100	0,28	4,4	0,67	3,3	2,83	4,8	3,35	4,3
125	0,23	6,9	0,53	5,1	2,26	7,6	2,67	6,7
150	0,19	9,9	0,44	7,4	1,72	10,0	2,22	9,7
175	0,14	11,7	0,37	10,1	1,26	11,7	1,67	11,7
200	0,10	13,3	0,32	13,2	0,96	13,3	1,27	13,3
225	0,08	15,0	0,25	15,0	0,75	15,0	0,99	15,0
250	0,06	16,7	0,20	16,7	0,60	16,7	0,79	16,7
275	0,05	18,3	0,16	18,3	0,48	18,3	0,64	18,3
300	0,04	20,0	0,13	20,0	0,40	20,0	0,53	20,0
325	0,03	21,7	0,11	21,7	0,33	21,7	0,44	21,7
350	0,02	23,3	0,09	23,3	0,28	23,3	0,37	23,3
375	0,02	25,0	0,07	25,0	0,23	25,0	0,31	25,0
400	0,01	26,7	0,06	26,7	0,19	26,7	0,26	26,7
425	0,01	28,3	0,05	28,3	0,16	28,3	0,22	28,3
450			0,04	30,0	0,14	30,0	0,18	30,0
475			0,03	31,7	0,11	31,7	0,15	31,7
500			0,02	33,3	0,09	33,3	0,12	33,3
525			0,01	35,0	0,08	35,0	0,10	35,0
550			0,01	36,7	0,06	36,7	0,08	36,7
575					0,05	38,3	0,06	38,3
600					0,03	40,0	0,04	40,0

Design notes Open Profiles

- Where applicable recommended values consider partial safety factors for actions and resistance
- Recommended stress (σ_{rec}) is determined using $\sigma_{\text{rec}} = (F_{y0}) / [(Y_{\text{red}}) \times (Y_m)]$ where
 - F_{y0} average yield strength (EN 1993-1-3:2024)
 - $Y_m = 1,1$ partial Safety Factor for global buckling (DIN EN 1993-1-3:2006)
 - $Y_{\text{red}} = 1,4$ partial Safety Factor for action loading

For further details behind calculations using this design method, please consult a Hilti engineer.

Technical Data for MT Profiles

(max. span width/deflection - distributed load along the span)

Open C-channels

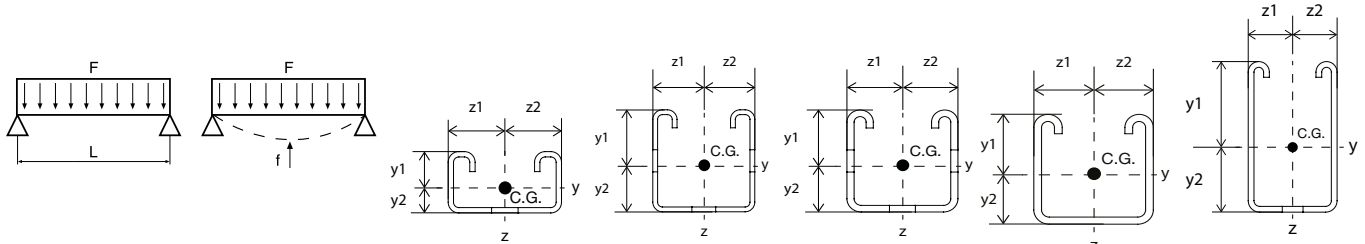

Max. span width L [cm] / deflection f [mm] - Result

span width L [cm]	MT-30/ MT-30 OC		MT-40/ MT-40 OC		MT-50/ MT-50 OC		MT-50 U/ MT-50 U OC		MT-60/ MT-60 OC	
	F	f	F	f	F	f	F	f	F	f
25	6,64	0,5	17,16	0,3	28,03	0,4	28,03	0,4	45,93	0,2
50	3,31	2,1	8,57	1,2	14,00	1,5	14,00	1,5	22,95	0,6
75	2,20	4,8	5,71	2,6	9,32	3,5	9,32	3,5	15,28	1,4
100	1,29	6,7	4,27	4,6	6,98	6,2	6,98	6,2	11,44	2,5
125	0,81	8,3	3,41	7,2	4,81	8,3	4,81	8,3	9,14	3,9
150	0,56	10,0	2,73	10,0	3,32	10,0	3,32	10,0	7,60	5,6
175	0,40	11,7	1,99	11,7	2,42	11,7	2,42	11,7	6,49	7,6
200	0,30	13,3	1,51	13,3	1,84	13,3	1,84	13,3	5,66	10,0
225	0,22	15,0	1,18	15,0	1,43	15,0	1,43	15,0	5,01	12,6
250	0,17	16,7	0,94	16,7	1,14	16,7	1,14	16,7	4,49	15,6
275	0,13	18,3	0,76	18,3	0,93	18,3	0,93	18,3	3,95	18,3
300	0,10	20,0	0,63	20,0	0,76	20,0	0,76	20,0	3,29	20,0
325	0,07	21,7	0,52	21,7	0,63	21,7	0,63	21,7	2,78	21,7
350	0,05	23,3	0,44	23,3	0,52	23,3	0,52	23,3	2,37	23,3
375	0,04	25,0	0,36	25,0	0,44	25,0	0,44	25,0	2,03	25,0
400	0,02	26,7	0,31	26,7	0,36	26,7	0,36	26,7	1,76	26,7
425	0,01	28,3	0,26	28,3	0,30	28,3	0,30	28,3	1,53	28,3
450			0,21	30,0	0,25	30,0	0,25	30,0	1,34	30,0
475			0,18	31,7	0,21	31,7	0,21	31,7	1,17	31,7
500			0,15	33,3	0,17	33,3	0,17	33,3	1,03	33,3
525			0,12	35,0	0,13	35,0	0,13	35,0	0,90	35,0
550			0,09	36,7	0,10	36,7	0,10	36,7	0,79	36,7
575			0,07	38,3	0,07	38,3	0,07	38,3	0,70	38,3
600			0,05	40,0	0,05	40,0	0,05	40,0	0,61	40,0

Design notes Open Profiles

• Where applicable recommended values consider partial safety factors for actions and resistance

• Recommended stress (σ_{rec}) is determined using $\sigma_{rec} = (f_{yd}) / ((\gamma_{m1}) \times (\gamma_{m2}))$ where

f_{yd} average yield strength (EN 1993-1-3:2024)

$\gamma_{m1} = 1,1$ partial Safety Factor for global buckling (DIN EN 1993-1-3:2006)

$\gamma_{m2} = 1,4$ partial Safety Factor for action loading

For further details behind calculations using this design method, please consult a Hilti engineer.

Version from 03.2026

Technical Data for MT Profiles

(max. span width/deflection - distributed load along the span)

Open C-channels

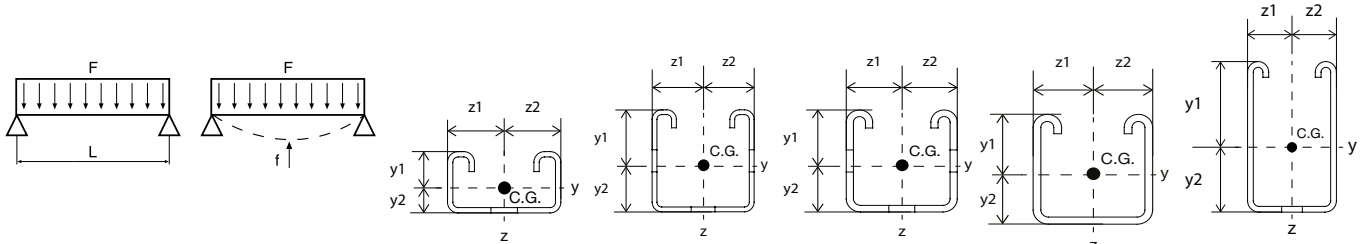

Max. span width L [cm] / deflection f [mm] - Result

span width L [cm]	MT-30/ MT-30 OC		MT-40 V2/ MT-40 V2 OC		MT-50/ MT-50 OC		MT-50 U/ MT-50 U OC		MT-60/ MT-60 OC	
	F	f	F	f	F	f	F	f	F	f
25	6,64	0,5	17,14	0,3	28,03	0,4	28,03	0,4	45,93	0,2
50	3,31	2,1	8,56	1,3	14,00	1,5	14,00	1,5	22,95	0,6
75	2,20	4,8	5,70	2,9	9,32	3,5	9,32	3,5	15,28	1,4
100	1,29	6,7	4,27	5,2	6,98	6,2	6,98	6,2	11,44	2,5
125	0,81	8,3	3,41	8,2	4,81	8,3	4,81	8,3	9,14	3,9
150	0,56	10,0	2,41	10,0	3,32	10,0	3,32	10,0	7,60	5,6
175	0,40	11,7	1,76	11,7	2,42	11,7	2,42	11,7	6,49	7,6
200	0,30	13,3	1,34	13,3	1,84	13,3	1,84	13,3	5,66	10,0
225	0,22	15,0	1,05	15,0	1,43	15,0	1,43	15,0	5,01	12,6
250	0,17	16,7	0,84	16,7	1,14	16,7	1,14	16,7	4,49	15,6
275	0,13	18,3	0,68	18,3	0,93	18,3	0,93	18,3	3,95	18,3
300	0,10	20,0	0,56	20,0	0,76	20,0	0,76	20,0	3,29	20,0
325	0,07	21,7	0,47	21,7	0,63	21,7	0,63	21,7	2,78	21,7
350	0,05	23,3	0,39	23,3	0,52	23,3	0,52	23,3	2,37	23,3
375	0,04	25,0	0,33	25,0	0,44	25,0	0,44	25,0	2,03	25,0
400	0,02	26,7	0,28	26,7	0,36	26,7	0,36	26,7	1,76	26,7
425	0,01	28,3	0,24	28,3	0,30	28,3	0,30	28,3	1,53	28,3
450			0,20	30,0	0,25	30,0	0,25	30,0	1,34	30,0
475			0,17	31,7	0,21	31,7	0,21	31,7	1,17	31,7
500			0,14	33,3	0,17	33,3	0,17	33,3	1,03	33,3
525			0,12	35,0	0,13	35,0	0,13	35,0	0,90	35,0
550			0,10	36,7	0,10	36,7	0,10	36,7	0,79	36,7
575			0,08	38,3	0,07	38,3	0,07	38,3	0,70	38,3
600			0,06	40,0	0,05	40,0	0,05	40,0	0,61	40,0

Design notes Open Profiles

• Where applicable recommended values consider partial safety factors for actions and resistance

• Recommended stress (σ_{rec}) is determined using $\sigma_{rec} = (f_{yd}) / [(Y_{red}) \times (Y_{m})]$ where

f_{yd} average yield strength (EN 1993-1-3:2024)

$Y_{m} = 1,1$ partial Safety Factor for global buckling (DIN EN 1993-1-3:2006)

$Y_{red} = 1,4$ partial Safety Factor for action loading

For further details behind calculations using this design method, please consult a Hilti engineer.

Version from 03.2026

Technical Data for MT Profiles

(max. span width/deflection - distributed load along the span)

double channels

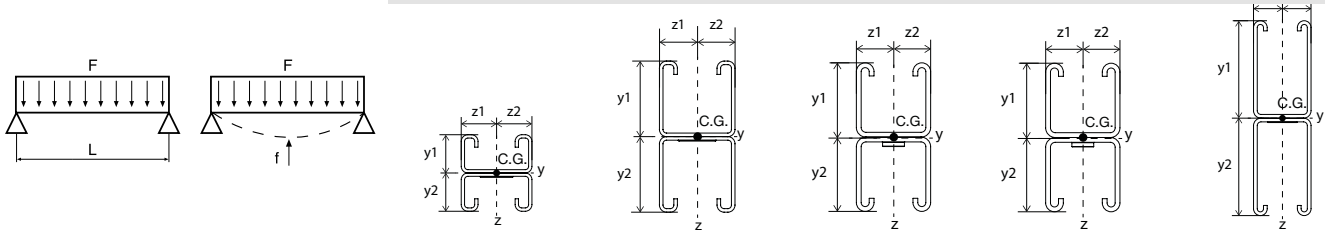

Max. span width L [cm] / deflection f [mm] - Result

span width L [cm]	MT-30D/ MT-30D OC		MT-40D/ MT-40D OC		MT-50 D		MT-50D U		MT-60D/ MT-60D OC	
	F	f	F	f	F	f	F	f	F	f
25	11,12* **	0,2	30,46*	0,1	41,91*	0,1	41,91*	0,1	89,65*	0,0
50	9,70* **	1,1	25,98*	0,6	41,91*	0,8	41,91*	0,8	82,92*	0,4
75	6,46**	2,5	17,30*	1,3	30,77*	1,9	30,77*	1,9	55,25*	0,8
100	4,83	4,4	12,96	2,4	23,06	3,3	23,06	3,3	41,40*	1,4
125	3,85	6,9	10,35	3,7	18,42	5,2	18,42	5,2	33,08*	2,2
150	3,19	10,0	8,60	5,3	15,32	7,5	15,32	7,5	27,53	3,2
175	2,33	11,7	7,35	7,2	13,11	10,2	13,11	10,2	23,56	4,3
200	1,76	13,3	6,42	9,4	11,42	13,3	11,42	13,3	20,58	5,6
225	1,37	15,0	5,68	11,9	8,98	15,0	8,98	15,0	18,25	7,1
250	1,09	16,7	5,09	14,7	7,24	16,7	7,24	16,7	16,39	8,8
275	0,88	18,3	4,61	17,8	5,95	18,3	5,95	18,3	14,86	10,7
300	0,72	20,0	3,96	20,0	4,96	20,0	4,96	20,0	13,59	12,7
325	0,59	21,7	3,34	21,7	4,19	21,7	4,19	21,7	12,50	14,9
350	0,49	23,3	2,85	23,3	3,57	23,3	3,57	23,3	11,57	17,3
375	0,41	25,0	2,45	25,0	3,07	25,0	3,07	25,0	10,76	19,8
400	0,34	26,7	2,13	26,7	2,66	26,7	2,66	26,7	10,05	22,5
425	0,28	28,3	1,85	28,3	2,32	28,3	2,32	28,3	9,42	25,5
450	0,23	30,0	1,62	30,0	2,03	30,0	2,03	30,0	8,86	28,5
475	0,18	31,7	1,42	31,7	1,78	31,7	1,78	31,7	8,32	31,7
500	0,14	33,3	1,26	33,3	1,57	33,3	1,57	33,3	7,45	33,3
525	0,11	35,0	1,11	35,0	1,38	35,0	1,38	35,0	6,70	35,0
550	0,08	36,7	0,98	36,7	1,22	36,7	1,22	36,7	6,05	36,7
575	0,05	38,3	0,86	38,3	1,08	38,3	1,08	38,3	5,47	38,3
600	0,02	40,0	0,76	40,0	0,95	40,0	0,95	40,0	4,97	40,0

Design notes Open Profiles

* Where applicable recommended values consider partial safety factors for actions and resistance

** Recommended stress (σ_{rec}) is determined using $\sigma_{rec} = (f_{yd}) / ((\gamma_{m1}) \times (\gamma_{m2}))$ where

f_{yd} average yield strength (EN 1993-1-3:2024)

$\gamma_{m1} = 1,1$ partial Safety Factor for global buckling (DIN EN 1993-1-3:2026)

$\gamma_{m2} = 1,4$ partial Safety Factor for action loading

67

* Span limited by shear flow resistance of back-to-back joints.

** Maximum load limited to 5.71kN due to back-to-back channel separation

For further details behind calculations using this design method, please consult a Hilti engineer.

Version from 03.2026

Boundary conditions - Terms of common cooperation / Legal disclaimer and guidelines as defined at the beginning of this book need to be mandatorily respected

Technical Data for MT Profiles

(max. span width/deflection - distributed load along the span)

double channels

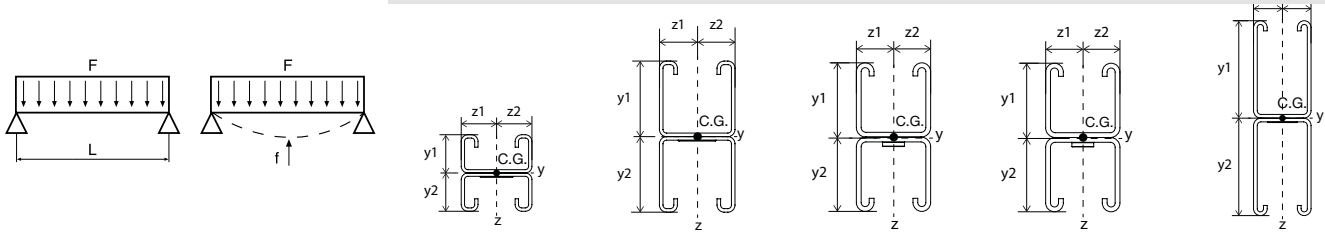

Max. span width L [cm] / deflection f [mm] - Result

span width L [cm]	MT-30D/ MT-30D OC		MT-40D V2/ MT-40D V2 OC		MT-50 D		MT-50D U		MT-60D/ MT-60D OC	
	F	f	F	f	F	f	F	f	F	f
25	11,12* **	0,2	26,31*	0,1	41,91*	0,1	41,91*	0,1	89,65*	0,0
50	9,70* **	1,1	26,31*	0,7	41,91*	0,8	41,91*	0,8	82,92*	0,4
75	6,46**	2,5	18,56*	1,7	30,77*	1,9	30,77*	1,9	55,25*	0,8
100	4,83	4,4	13,91	2,9	23,06	3,3	23,06	3,3	41,40*	1,4
125	3,85	6,9	11,11	4,6	18,42	5,2	18,42	5,2	33,08*	2,2
150	3,19	10,0	9,25	6,6	15,32	7,5	15,32	7,5	27,53	3,2
175	2,33	11,7	7,91	9,0	13,11	10,2	13,11	10,2	23,56	4,3
200	1,76	13,3	6,91	11,8	11,42	13,3	11,42	13,3	20,58	5,6
225	1,37	15,0	6,13	14,9	8,98	15,0	8,98	15,0	18,25	7,1
250	1,09	16,7	4,98	16,7	7,24	16,7	7,24	16,7	16,39	8,8
275	0,88	18,3	4,10	18,3	5,95	18,3	5,95	18,3	14,86	10,7
300	0,72	20,0	3,42	20,0	4,96	20,0	4,96	20,0	13,59	12,7
325	0,59	21,7	2,90	21,7	4,19	21,7	4,19	21,7	12,50	14,9
350	0,49	23,3	2,48	23,3	3,57	23,3	3,57	23,3	11,57	17,3
375	0,41	25,0	2,14	25,0	3,07	25,0	3,07	25,0	10,76	19,8
400	0,34	26,7	1,86	26,7	2,66	26,7	2,66	26,7	10,05	22,5
425	0,28	28,3	1,62	28,3	2,32	28,3	2,32	28,3	9,42	25,5
450	0,23	30,0	1,43	30,0	2,03	30,0	2,03	30,0	8,86	28,5
475	0,18	31,7	1,26	31,7	1,78	31,7	1,78	31,7	8,32	31,7
500	0,14	33,3	1,11	33,3	1,57	33,3	1,57	33,3	7,45	33,3
525	0,11	35,0	0,99	35,0	1,38	35,0	1,38	35,0	6,70	35,0
550	0,08	36,7	0,88	36,7	1,22	36,7	1,22	36,7	6,05	36,7
575	0,05	38,3	0,78	38,3	1,08	38,3	1,08	38,3	5,47	38,3
600	0,02	40,0	0,70	40,0	0,95	40,0	0,95	40,0	4,97	40,0

Design notes Open Profiles

• Where applicable recommended values consider partial safety factors for actions and resistance

• Recommended stress (σ_{rec}) is determined using $\sigma_{rec} = (f_{yd}) / ((\gamma_{red}) \times (\gamma_{m}))$ where

f_{yd} average yield strength (EN 1993-1-3:2024)

$\gamma_m = 1,1$ partial Safety Factor for global buckling (DIN EN 1993-1-3:2026)

$\gamma_{red} = 1,4$ partial Safety Factor for action loading

* Span limited by shear flow resistance of back-to-back joints.

** Maximum load limited to 5.71kN due to back-to-back channel separation

For further details behind calculations using this design method, please consult a Hilti engineer.

Version from 03.2026

Technical Data for MT Profiles

(max. span width/deflection - **distributed load along the span**)

Box Profiles

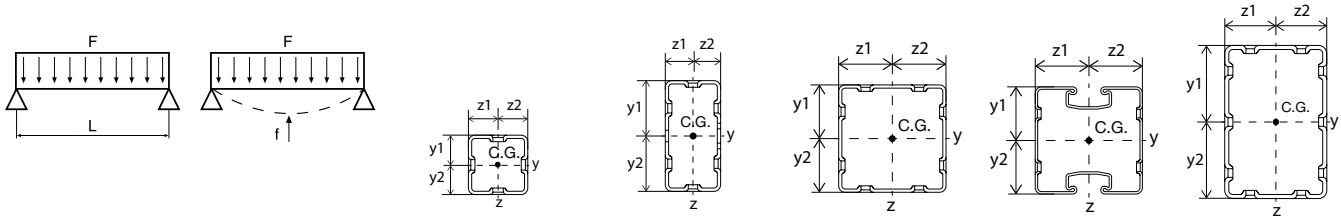

Max. span width L [cm] / deflection f [mm] - Result

span width L [cm]	MT-70 OC		MT-80 OC		MT-90 OC		MT-90H OC		MT-100 OC	
	F	f	F	f	F	f	F	f	F	f
25	46,81	0,3	124,49	0,1	106,17	0,1	60,13	0,0	222,70	0,0
50	28,31	1,4	78,71	0,7	106,17	0,5	60,13	0,3	222,70	0,4
75	18,86	3,1	52,45	1,6	81,71	1,4	60,13	1,0	196,32	1,1
100	14,13	5,5	39,31	2,8	61,24	2,5	60,13	2,4	147,18	1,9
125	10,87	8,3	31,42	4,3	48,95	3,9	56,75	4,4	117,67	2,9
150	7,53	10,0	26,16	6,2	40,75	5,7	47,25	6,3	97,99	4,2
175	5,50	11,7	22,39	8,5	34,89	7,7	40,46	8,6	83,92	5,7
200	4,19	13,3	19,56	11,1	30,49	10,1	35,36	11,2	73,36	7,5
225	3,28	15,0	17,36	14,0	27,06	12,8	31,39	14,2	65,14	9,5
250	2,63	16,7	14,99	16,7	24,31	15,8	26,84	16,7	58,55	11,7
275	2,15	18,3	12,35	18,3	21,20	18,3	22,12	18,3	53,16	14,2
300	1,78	20,0	10,34	20,0	17,75	20,0	18,53	20,0	48,66	16,9
325	1,49	21,7	8,76	21,7	15,06	21,7	15,73	21,7	44,84	19,8
350	1,26	23,3	7,51	23,3	12,93	23,3	13,50	23,3	41,57	23,0
375	1,07	25,0	6,50	25,0	11,20	25,0	11,70	25,0	36,70	25,0
400	0,91	26,7	5,67	26,7	9,78	26,7	10,22	26,7	32,15	26,7
425	0,78	28,3	4,98	28,3	8,60	28,3	8,99	28,3	28,37	28,3
450	0,67	30,0	4,40	30,0	7,61	30,0	7,96	30,0	25,20	30,0
475	0,57	31,7	3,91	31,7	6,76	31,7	7,08	31,7	22,51	31,7
500	0,49	33,3	3,48	33,3	6,04	33,3	6,33	33,3	20,21	33,3
525	0,41	35,0	3,12	35,0	5,41	35,0	5,67	35,0	18,22	35,0
550	0,35	36,7	2,80	36,7	4,87	36,7	5,11	36,7	16,49	36,7
575	0,29	38,3	2,51	38,3	4,39	38,3	4,61	38,3	14,98	38,3
600	0,24	40,0	2,27	40,0	3,97	40,0	4,17	40,0	13,65	40,0

Design notes Box Profiles

- Where applicable recommended values consider partial safety factors for actions and resistance
- Recommended stress (σ_{rec}) is determined using $\sigma_{rec} = (f_y) / [(\gamma_{Hilti}) \times (\gamma_{m})]$ where
 - f_y yield strength (EN 1993-1-1:2022)
 - $\gamma_{m} = 1,0$ (MT-80, MT-90, MT-100); $1,1$ (MT-70, MT-90H) partial Safety Factor for cross-sections (EN 1993-1-1:2022)
 - $\gamma_{Hilti} = 1,4$ (MT-70); $1,5$ (MT-80, MT-90, MT-90H, MT-100) partial Safety Factor for action loading

For further details behind calculations using this design method, please consult a Hilti engineer.

Buckling

2

Recommended buckling load for MT Profiles

Trapeze Profiles

Open C-channels

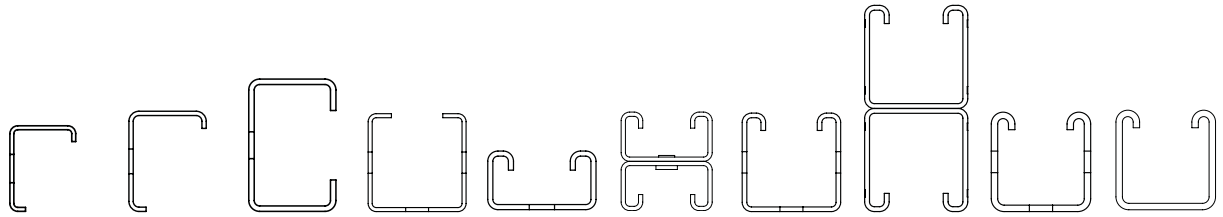

Recommended buckling load [kN]

Buckling length Sk [cm]	MT-10	MT-15 / MT-15 OC	MT-20 / MT-20 OC	MT-40 T / MT-40 T OC	MT-30 / MT-30 OC	MT-30D / MT-30D OC	MT-40 / MT-40 OC	MT-40D / MT-40D OC	MT-50 / MT-50 OC	MT-50 U / MT-50 U OC
25			27,63	31,40	28,39	73,41	38,75	87,97	50,60	55,68
50			21,28	23,28	18,60	64,66	28,88	80,21	36,91	47,92
75			15,59	15,96	11,68	54,86	19,78	72,00	25,25	39,23
100			11,86	11,31	7,95	44,36	13,90	62,95	18,14	30,58
125			9,63	8,56	5,81	34,76	10,42	53,45	13,97	23,51
150			8,19	6,86	4,46	27,14	8,26	44,43	11,35	18,32
175	N/A	N/A	6,33	5,73	3,54	21,45	6,83	36,66	9,58	14,62
200			5,03	4,93	2,88	17,25	5,82	30,34	8,29	11,94
225			4,08	4,33	2,38	14,12	5,08	25,32	7,29	9,97
250			3,37	3,86	2,01	11,75	4,51	21,35	6,49	8,46
275			2,83	3,47	1,71	9,92	4,04	18,20	5,83	7,29
300			2,41	3,15	1,47	8,47	3,66	15,67	5,27	6,36

Flexural buckling:
 Rod length l (cm) / euler factor
 β/Sk (cm) effective length
 $= l \cdot \beta$

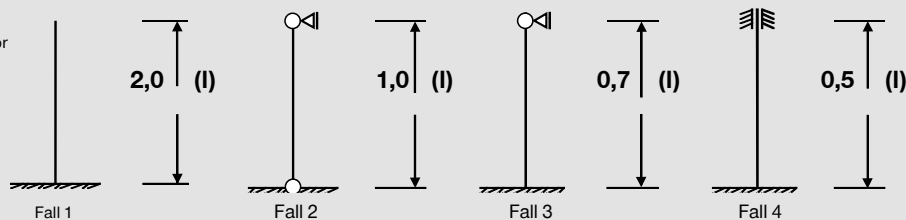

Design notes Open Profiles

- Where applicable recommended values consider partial safety factors for actions and resistance
- Recommended stress (σ_{rec}) is determined using $\sigma_{rec} = (f_{yb}) / [(Y_{Hilti}) \times (Y_m)]$ where
 - f_{yb} average yield strength (EN 1993-1-3:2024)
 - $Y_m = 1,1$ partial Safety Factor for global buckling (DIN EN 1993-1-3:2006)
 - $Y_{Hilti} = 1,4$ partial Safety Factor for action loading

For further details behind calculations using this design method, please consult a Hilti engineer.

Buckling

2

Recommended buckling load for MT Profiles

Trapeze Profiles

Open C-channels

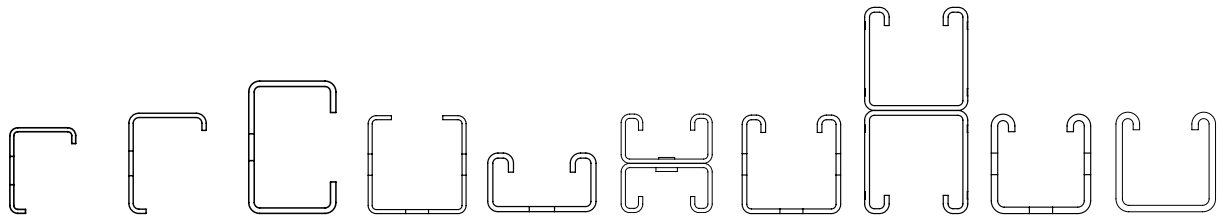

Recommended buckling load [kN]

Buckling length Sk [cm]	MT-10	MT-15 / MT-15 OC	MT-20 / MT-20 OC	MT-40 T / MT-40 T OC	MT-30 / MT-30 OC	MT-30D / MT-30D OC	MT-40 V2 / MT-40 V2 OC	MT-40D V2 / MT-40D V2 OC	MT-50 / MT-50 OC	MT-50 U / MT-50 U OC
25			27,63	31,40	28,39	73,41	36,54	91,71	50,60	55,68
50			21,28	23,28	18,60	64,66	31,71	83,98	36,91	47,92
75			15,59	15,96	11,68	54,86	26,28	75,88	25,25	39,23
100			11,86	11,31	7,95	44,36	20,70	66,97	18,14	30,58
125			9,63	8,56	5,81	34,76	15,96	57,52	13,97	23,51
150	N/A	N/A	8,19	6,86	4,46	27,14	12,40	48,34	11,35	18,32
175	N/A	N/A	6,33	5,73	3,54	21,45	9,84	40,23	9,58	14,62
200			5,03	4,93	2,88	17,25	7,98	33,49	8,29	11,94
225			4,08	4,33	2,38	14,12	6,60	28,07	7,29	9,97
250			3,37	3,86	2,01	11,75	5,57	23,74	6,49	8,46
275			2,83	3,47	1,71	9,92	4,77	20,28	5,83	7,29
300			2,41	3,15	1,47	8,47	4,14	17,49	5,27	6,36

Flexural buckling:
 Rod length l (cm) / euler factor
 β/Sk (cm) effective length
 $= l \cdot \beta$

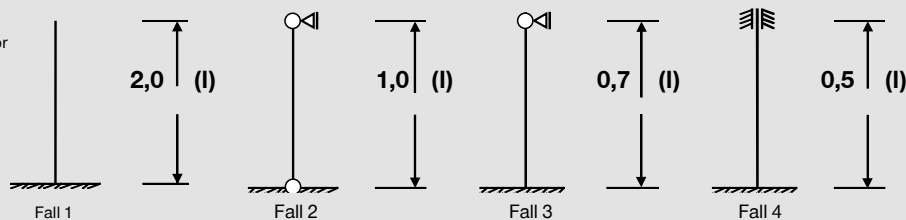

Design notes Open Profiles

- Where applicable recommended values consider partial safety factors for actions and resistance
- Recommended stress (σ_{rec}) is determined using $\sigma_{rec} = (f_{yb}) / [(Y_{Hilti}) \times (Y_m)]$ where
 - f_{yb} average yield strength (EN 1993-1-3:2024)
 - $Y_m = 1,1$ partial Safety Factor for global buckling (DIN EN 1993-1-3:2006)
 - $Y_{Hilti} = 1,4$ partial Safety Factor for action loading

For further details behind calculations using this design method, please consult a Hilti engineer.

Buckling

2

Recommended buckling load for MT Profiles

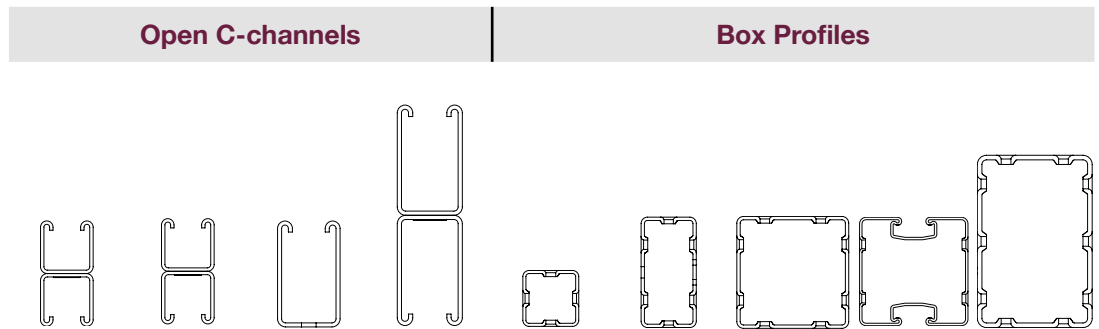

Recommended buckling load [kN]

Buckling length Sk [cm]	MT-50D	MT-50D U	MT-60 / MT-60 OC	MT-60D / MT-60D OC	MT-70 OC	MT-80 OC	MT-90 OC	MT-90H OC	MT-100 OC
25	117,05	117,05	68,93	193,90	92,41	128,31	219,78	236,56	350,41
50	106,39	106,39	52,16	177,75	84,57	118,07	210,74	226,11	336,93
75	95,04	95,04	36,33	160,84	76,34	107,42	202,00	215,28	323,55
100	82,51	82,51	25,80	142,28	67,29	95,79	193,28	204,32	310,24
125	69,48	69,48	19,47	122,54	57,70	83,33	184,34	192,90	296,65
150	57,33	57,33	15,55	103,27	48,42	70,94	175,02	180,84	282,54
175	47,03	47,03	12,97	86,13	40,25	59,66	165,24	168,13	267,77
200	38,77	38,77	11,18	71,82	33,48	50,05	155,00	154,92	252,31
225	32,26	32,26	9,86	60,25	28,04	42,18	144,40	141,57	236,27
250	27,16	27,16	8,86	51,00	23,70	35,81	133,67	128,50	219,89
275	23,11	23,11	8,06	43,59	20,24	30,67	123,05	116,10	203,52
300	19,88	19,88	7,41	37,60	17,45	26,51	112,80	104,65	187,54

Flexural buckling:

Rod length l (cm) / euler factor
 β/Sk (cm) effective length
 $= l \cdot \beta$

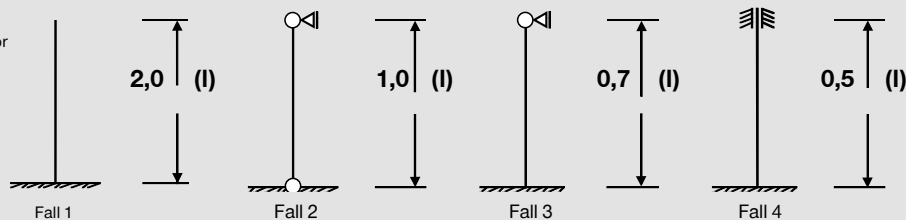

Design notes Open Profiles

- Where applicable recommended values consider partial safety factors for actions and resistance
- Recommended stress (σ_{rec}) is determined using $\sigma_{rec} = (f_y) / [(Y_{Hilti}) \times (Y_m)]$ where
 - f_y average yield strength (EN 1993-1-3:2024)
 - $Y_m = 1,1$ partial Safety Factor for global buckling (DIN EN 1993-1-3:2006)
 - $Y_{Hilti} = 1,4$ partial Safety Factor for action loading

Design notes Box Profiles

- Where applicable recommended values consider partial safety factors for actions and resistance
- Recommended stress (σ_{rec}) is determined using $\sigma_{rec} = (f_y) / [(Y_{Hilti}) \times (Y_m)]$ where
 - f_y yield strength (EN 1993-1-1:2022)
 - $Y_m = 1,0$ (MT-80, MT-90, MT-100); $1,1$ (MT-70, MT-90H) partial Safety Factor for cross-sections (EN 1993-1-1:2022)
 - $Y_{Hilti} = 1,4$ (MT-70); $1,5$ (MT-80, MT-90, MT-90H, MT-100) partial Safety Factor for action loading

For further details behind calculations using this design method, please consult a Hilti engineer.

3. MT Brackets

3

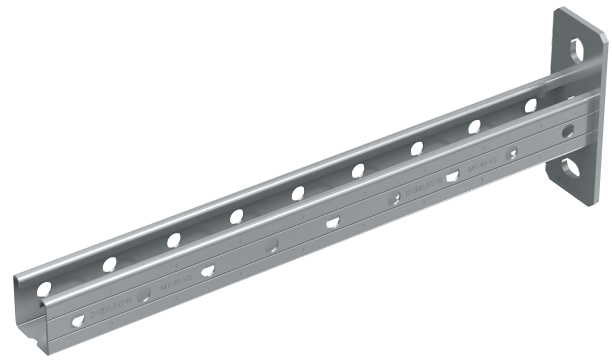
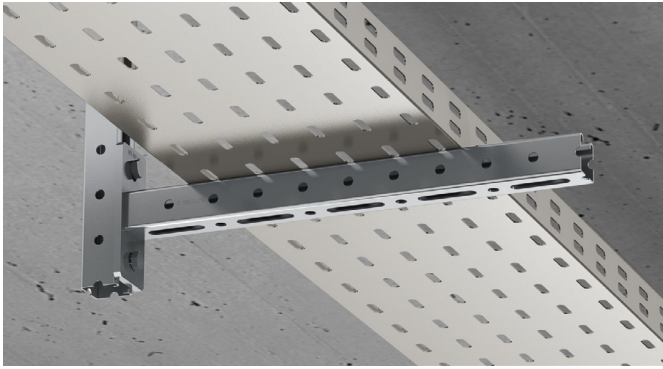

Applications

- Supporting pipe rings, ventilation ducts, cable trays and other MEP support hardware
- Mounting light-duty MEP installations on concrete and steel
- Suitable for use in dry, indoor environments

Advantages

- Part of the Hilti MT system – an economical, all-in-one solution for virtually all modular MEP support structures
- Economical – high load/weight ratio and rapid assembly make MT C-Channel a more efficient alternative to welded MEP support structures
- Easy to install – compatible with the Hilti MT Twist-Lock, a faster alternative to spring nuts for assembling a modular support system

Technical data

Material composition	Q235 or better steel
Surface finish	Electro-galvanized - for dry indoor use only

MT-BR-30 300 / 450 Bracket

Order designation	Technical data	Sales pack quantity	Item number	
MT-BR-30 300	Dry indoor conditions (C1) Indoor with temporary condensation (C2)	12 pc	2271288	
MT-BR-30 450		16 pc	2271440	

MT-BR-40 300 / 450 / 600 / 1000 Bracket

Order designation	Technical data	Sales pack quantity	Item number	
MT-BR-40 300	Dry indoor conditions (C1) Indoor with temporary condensation (C2)	10 pc	2271442	
MT-BR-40 450		10 pc	2271444	
MT-BR-40 600		10 pc	2271451	
MT-BR-40 1000		10 pc	2271446	

MT-BR-40 V2 300 / 450 / 600 / 1000 Bracket

Order designation	Technical data	Sales pack quantity	Item number	
MT-BR-40 V2 300	Dry indoor conditions (C1) Indoor with temporary condensation (C2)	10 pc	2465800	
MT-BR-40 V2 450		10 pc	2465795	
MT-BR-40 V2 600		10 pc	2465796	
MT-BR-40 V2 1000		10 pc	2465585	

MT Brackets - Outdoor

3

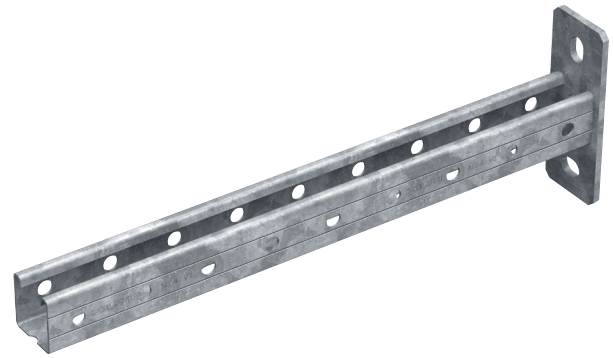
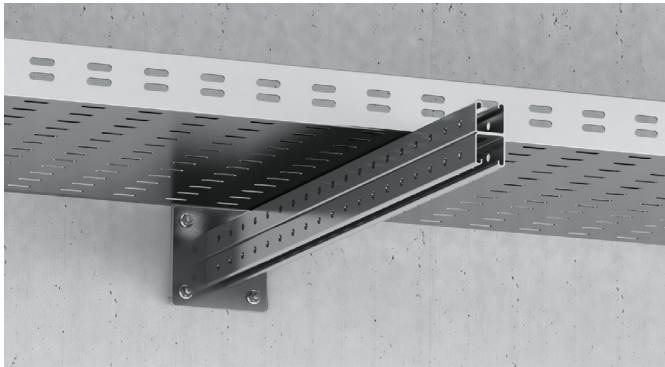

Applications

- Supporting pipe rings, ventilation ducts, cable trays and other MEP support hardware
- Mounting light-duty MEP installations on concrete and steel
- Suitable for use in moderately corrosive environments

Advantages

- Part of the Hilti MT system – an economical, all-in-one solution for virtually all modular MEP support structures
- Economical – high load/weight ratio and rapid assembly make MT C-channel a more efficient alternative to welded MEP support structures
- Easy to install – compatible with the Hilti MT Twist-Lock for assembling a modular support system
- Comes also with four anchorage holes versions for enhanced resistance against lateral forces

Technical Data

Material composition	Q235 or better steel
Surface finish	Hot-dip galvanized (56 µm ASTM A153M) for outdoor use

MT-BR-30 300 / 450 OC Bracket - Outdoor

Order designation	Technical Data	Sales pack quantity	Item number	
MT-BR-30 300 OC	Outdoor, low to moderate pollution (C3 / C4 - low)	12 pc	2271289	
MT-BR-30 450 OC		16 pc	2271441	

MT-BR-40 300 / 450 / 600 / 1000 OC Bracket - Outdoor

Order designation	Technical Data	Sales pack quantity	Item number	
MT-BR-40 300 OC	Outdoor, low to moderate pollution (C3 / C4 - low)	10 pc	2271443	
MT-BR-40 450 OC		10 pc	2271445	
MT-BR-40 600 OC		10 pc	2271452	
MT-BR-40 1000 OC		10 pc	2271447	

MT-BR-40 V2 300 / 450 / 600 / 1000 OC Bracket - Outdoor

Order designation	Technical Data	Sales pack quantity	Item number	
MT-BR-40 V2 300 OC	Outdoor, low to moderate pollution (C3 / C4 - low)	10 pc	2465801	
MT-BR-40 V2 450 OC		10 pc	2465794	
MT-BR-40 V2 600 OC		10 pc	2465802	
MT-BR-40 V2 1000 OC		10 pc	2465579	

MT Brackets - Outdoor

3

MT-BR-40 O4 600 / 1000 OC Bracket - Outdoor

Order designation	Technical Data	Sales pack quantity	Item number	
MT-BR-40 O4 600 OC	Outdoor, low to moderate pollution (C3 / C4 - low)	4 pc	2271455	
MT-BR-40 O4 1000 OC		4 pc	2271456	

MT-BR-40D 600 / 1000 OC Bracket - Outdoor

Order designation	Technical Data	Sales pack quantity	Item number	
MT-BR-40D 600	Outdoor, low to moderate pollution (C3 / C4 - low)	6 pc	2271449	
MT-BR-40D 1000		6 pc	2271453	

MT-BR-40D V2 600 / 1000 OC Bracket - Outdoor

Order designation	Technical Data	Sales pack quantity	Item number	
MT-BR-40D V2 600	Outdoor, low to moderate pollution (C3 / C4 - low)	6 pc	2465797	
MT-BR-40D V2 1000		6 pc	2465595	

MT-BR-40D O4 600 / 1000 / 1500 OC Bracket - Outdoor

Order designation	Technical Data	Sales pack quantity	Item number	
MT-BR-40D O4 600 OC	Outdoor, low to moderate pollution (C3 / C4 - low)	4 pc	2271459	
MT-BR-40D O4 1000 OC		4 pc	2271461	
MT-BR-40D O4 1500 OC		2 pc	2271287	

MT Brackets - (Outdoor)

3

Technical Data for Brackets (Hot-dip galvanized)

		HST4(-R) M10 / HUS4-H(F) 8	HST4(-R) M10 / HUS4-H(F) 8	HST4(-R) M10 / HUS4-H(F) 8	HST4(-R) M10 / HUS4-H(F) 8	HST4(-R) M10 / HUS4-H(F) 8
Bracket without bracing	L	F1	F1	F1	F2	F3
	[mm]	N	N	N	N	N
MT-BR-30/300 / OC	300	549	549	362	274	183
MT-BR-30/450 / OC	450	433	433	249	217	144

Technical Data for Brackets (Hot-dip galvanized)

		HST4(-R) M12 / HUS4-H(F) 10	HST4(-R) M12 / HUS4-H(F) 10	HST4(-R) M12 / HUS4-H(F) 10	HST4(-R) M12 / HUS4-H(F) 10	HST4(-R) M12 / HUS4-H(F) 10
Bracket without bracing	L	F1	F1	F1	F2	F3
	[mm]	N	N	N	N	N
MT-BR-40 V2/300	300	3805	3805	1903	1903	1268
MT-BR-40 V2/450	450	2533	2533	1267	1267	844
MT-BR-40 V2/600	600	1896	1896	948	948	632
MT-BR-40 V2/1000	1000	1123	1128	421	564	376
MT-BR-40 O4/600	600	1416	1416	796	708	472
MT-BR-40 O4/1000	1000	922	922	478	461	307
MT-BR-40D V2/600	600	3126	3126	1563	1563	1042
MT-BR-40D V2/1000	1000	1857	1857	928	928	619
MT-BR-40D O4/600	600	3511	3511	2035	1755	1170
MT-BR-40D O4/1000	1000	2347	2347	1293	1174	782
MT-BR-40D O4/1500	1500	1642	1642	879	821	547

Design notes

anchors HST4(-R) M12 with anchorage depth of hef=70mm
anchors HST4(-R) M10 with anchorage depth of hef=60mm
anchors HUS4-H(F) 10 with anchorage depth of hef=67mm
anchors HUS4-H(F) 8 with anchorage depth of hef=55mm
cracked concrete³ C20/25
anchor resistance based on infinite edge distance
all holes must be filled with Hilti HIT-HY dynamic set
all anchors must work for shear, therefore holes must be filled with Hilti HIT-HY dynamic set
maximum deflection of L/75 considered
self weight of channel considered

4. MT Connectors

4 MT Open C-Channel Connectors 90° Connectors

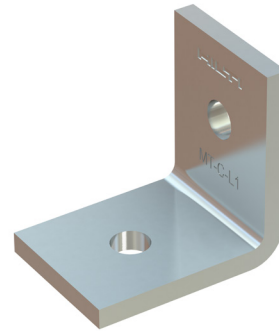

Applications

- Right-angle connections between any MT Profiles
- Assembling 2D metal framing for MEP support structures with light loads
- Suitable for use in dry, indoor environments

Technical data

Material composition	see detailed table
Surface finish	Pre-galvanized - for dry indoor use only

Advantages

- Part of the Hilti MT system – an economical, all-in-one solution for virtually all modular MEP support structures
- Easy to install – compatible with the Hilti MT Twist-Lock, a faster alternative to spring nuts for assembling a modular support system
- Adaptable – unlike welding, angle Brackets allow you to modify C-Channel framing during installation and for future MEP requirements
- MT-C-T 3D Connectors provide 3D frame possibilities
- MT-C-T/1 provides an alternative to using vertical double Channels
- MT-C-T A has a threaded hole on its short face, enabling the easy Fixation of C-Channels through the backside using a MT-CTAB bolt

MT-C-L1 Connector

Order Designation	Material composition	Technical data	Sales pack quantity	Item number	
MT-C-L1	Q355 or better steel	Dry indoor conditions (C1) Indoor with temporary condensation (C2)	20 pc	2271514	

MT-C-L2 Connector

Order Designation	Material composition	Technical data	Sales pack quantity	Item number	
MT-C-L2	Q355 or better steel	Dry indoor conditions (C1) Indoor with temporary condensation (C2)	20 pc	2271518	

MT Open C-Channel Connectors

90° Connectors

MT-C-LL1 Connector

Order Designation	Material composition	Technical data	Sales pack quantity	Item number	
MT-C-LL1	Q235 or better steel	Dry indoor conditions (C1) Indoor with temporary condensation (C2)	10 pc	2272047	

MT-C-LL2 Connector

Order Designation	Material composition	Technical data	Sales pack quantity	Item number	
MT-C-LL2	Q235 or better steel	Dry indoor conditions (C1) Indoor with temporary condensation (C2)	10 pc	2272051	

MT-C-T/2 Connector

Order Designation	Material composition	Technical data	Sales pack quantity	Item number	
MT-C-T/2	Q235 or better steel	Dry indoor conditions (C1) Indoor with temporary condensation (C2)	15 pc	2272054	

MT-C-T A Connector

Order Designation	Material composition	Technical data	Sales pack quantity	Item number	
MT-C-T A	Q355 or better steel	Dry indoor conditions (C1) Indoor with temporary condensation (C2)	20 pc	2272056	

MT Open C-Channel Connectors

90° Connectors

4

MT-C-T/1 Connector

Order Designation	Material composition	Technical data	Sales pack quantity	Item number	
MT-C-T/1	Q355 or better steel	Dry indoor conditions (C1) Indoor with temporary condensation (C2)	20 pc	2272040	

MT-C-T 3D/2 Connector

Order Designation	Material composition	Technical data	Sales pack quantity	Item number	
MT-C-T 3D/2	Q355 or better steel	Dry indoor conditions (C1) Indoor with temporary condensation (C2)	10 pc	2272058	

MT-C-T 3D/3 Connector

Order Designation	Material composition	Technical data	Sales pack quantity	Item number	
MT-C-T 3D/3	Q355 or better steel	Dry indoor conditions (C1) Indoor with temporary condensation (C2)	10 pc	2272060	

MT Open C-Channel Connectors

90° Connectors - Outdoor

4

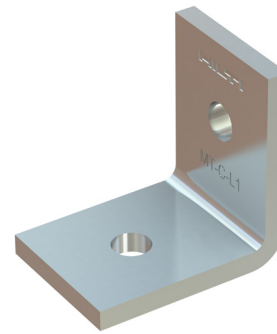

Applications

- Right-angle connections between any MT Profiles
- Assembling 2D metal framing for MEP support structures with light loads
- Suitable for use in moderately corrosive environments

Technical Data

Material composition	Q355 or better steel
Surface finish	Hot-dip galvanized - for outdoor use

Advantages

- Part of the Hilti MT system – an economical, all-in-one solution for virtually all modular MEP support structures
- Easy to install – compatible with the Hilti MT Twist-Lock, a faster alternative to spring nuts for assembling a modular support system
- Adaptable – unlike welding, angle Brackets allow you to modify C-Channel framing during installation and for future MEP requirements
- MT-C-T 3D Connectors provide 3D frame possibilities
- MT-C-T/1 provides an alternative to using vertical double Channels
- MT-C-T A has a threaded hole on its short face, enabling the easy Fixation of C-Channels through the backside using a MT-CTAB bolt

MT-C-L1 OC Connector - Outdoor

Order Designation	Material composition	Technical Data	Sales pack quantity	Item number	
MT-C-L1 OC	Q355 or better steel	Outdoor, low to moderate pollution (C3 / C4 - low)	20 pc	2271516	

MT-C-L2 OC Connector - Outdoor

Order Designation	Material composition	Technical Data	Sales pack quantity	Item number	
MT-C-L2 OC	Q355 or better steel	Outdoor, low to moderate pollution (C3 / C4 - low)	20 pc	2271519	

MT Open C-Channel Connectors

90° Connectors - Outdoor

4

MT-C-LL1 OC Connector - Outdoor

Order Designation	Material composition	Technical Data	Sales pack quantity	Item number	
MT-C-LL1 OC	Q235 or better steel	Outdoor, low to moderate pollution (C3 / C4 - low)	10 pc	2272049	

MT-C-LL2 OC Connector - Outdoor

Order Designation	Material composition	Technical Data	Sales pack quantity	Item number	
MT-C-LL2 OC	Q235 or better steel	Outdoor, low to moderate pollution (C3 / C4 - low)	10 pc	2272053	

MT-C-T/1 OC Connector - Outdoor

Order Designation	Material composition	Technical Data	Sales pack quantity	Item number	
MT-C-T/1 OC	Q355 or better steel	Outdoor, low to moderate pollution (C3 / C4 - low)	20 pc	2272042	

MT-C-T/2 OC Connector - Outdoor

Order Designation	Material composition	Technical Data	Sales pack quantity	Item number	
MT-C-T/2 OC	Q235 or better steel	Outdoor, low to moderate pollution (C3 / C4 - low)	15 pc	2272055	

MT-C-T 3D/2 OC Connector - Outdoor

Order Designation	Material composition	Technical Data	Sales pack quantity	Item number	
MT-C-T 3D/2 OC	Q355 or better steel	Outdoor, low to moderate pollution (C3 / C4 - low)	10 pc	2272059	

MT Open C-Channel Connectors

4

MT-C-T 3D/3 OC Connector - Outdoor

Order Designation	Material composition	Technical Data	Sales pack quantity	Item number	
MT-C-T 3D/3 OC	Q355 or better steel	Outdoor, low to moderate pollution (C3 / C4 - low)	10 pc	2272061	

MT-C-T A OC Connector - Outdoor

Order Designation	Material composition	Technical Data	Sales pack quantity	Item number	
MT-C-T A OC	Q355 or better steel	Outdoor, low to moderate pollution (C3 / C4 - low)	20 pc	2272057	

MT Open C-Channel Connectors

4

Technical Data Connector

Item image	Load drawing	Order Designation	+ Fz	- Fz	± Fx	± Fy
		MT-C-L1 / MT-C-L1 OC	4,0 kN	3,3 kN	3,3 kN	-
		MT-C-L2 / MT-C-L2 OC	8,8 kN	5,7 kN	2,8 kN	1,1 kN
		MT-C-LL1 / MT-C-LL1 OC	5,9 kN	5,8 kN	5,8 kN	0,9 kN
		MT-C-LL2 / MT-C-LL2 OC	4,6 kN	4,1 kN	4,1 kN	0,6 kN

Design notes

- Shown load values are recommended values with partial safety factors for actions and resistance included
- Design value = 1.4 * recommended value
- The design resistance of the products is defined in accordance with EN1993

MT Open C-Channel Connectors

90° Connectors

Technical Data Connector

4

Item image	Load drawing	Order Designation	+ Fz	- Fz	± Fx	± Fy
		MT-C-T/1 / MT-C-T/1 OC	2,8 kN	3,9 kN	4,6 kN	0,9 kN
		MT-C-T/2 / MT-C-T/2 OC	2,6 kN	2,6 kN	8,1 kN	1,1 kN
		MT-C-T 3D/2 / MT-C-T 3D/2 OC	2,6 kN	1,5 kN	1,6 kN	0,5 kN
		MT-C-T 3D/3 / MT-C-T 3D/3 OC	2,2 kN	2,2 kN	3,6 kN	0,8 kN
		MT-C-T A / MT-C-T A OC	2,0 kN	2,0 kN	6,3 kN	2,0 kN

Design notes

- Shown load values are recommended values with partial safety factors for actions and resistance included
- Design value = 1.4 * recommended value
- The design resistance of the products is defined in accordance with EN1993

MT Open C-Channel Connectors

90° Connectors

Operation Instruction

MT-C-L1 / MT-C-L1 OC

4

2288322-06.2020

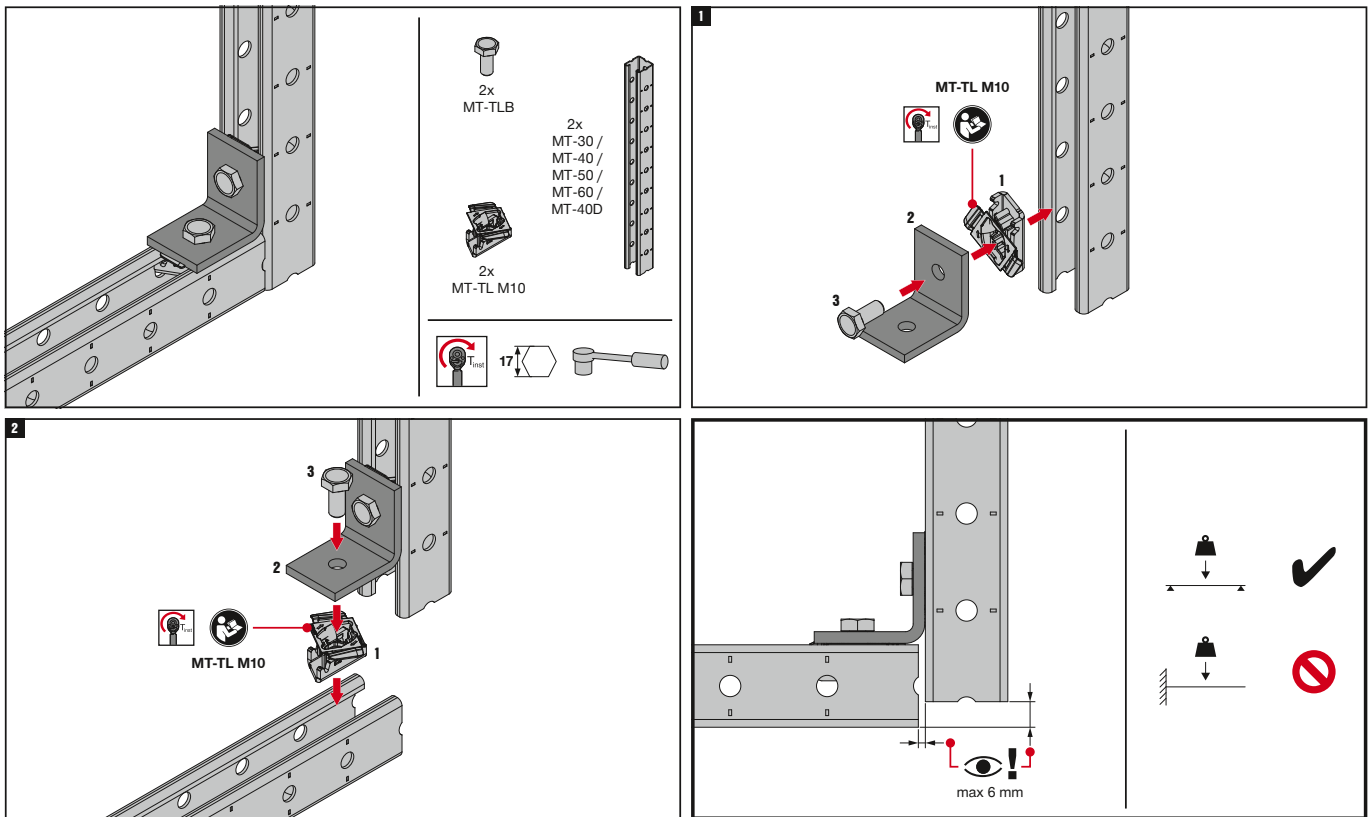

The latest IFU (Instruction for Use) is available on Hilti Online. Please check for any revisions before installing the product.

MT-C-L2 / MT-C-L2 OC

2288323-07.2020

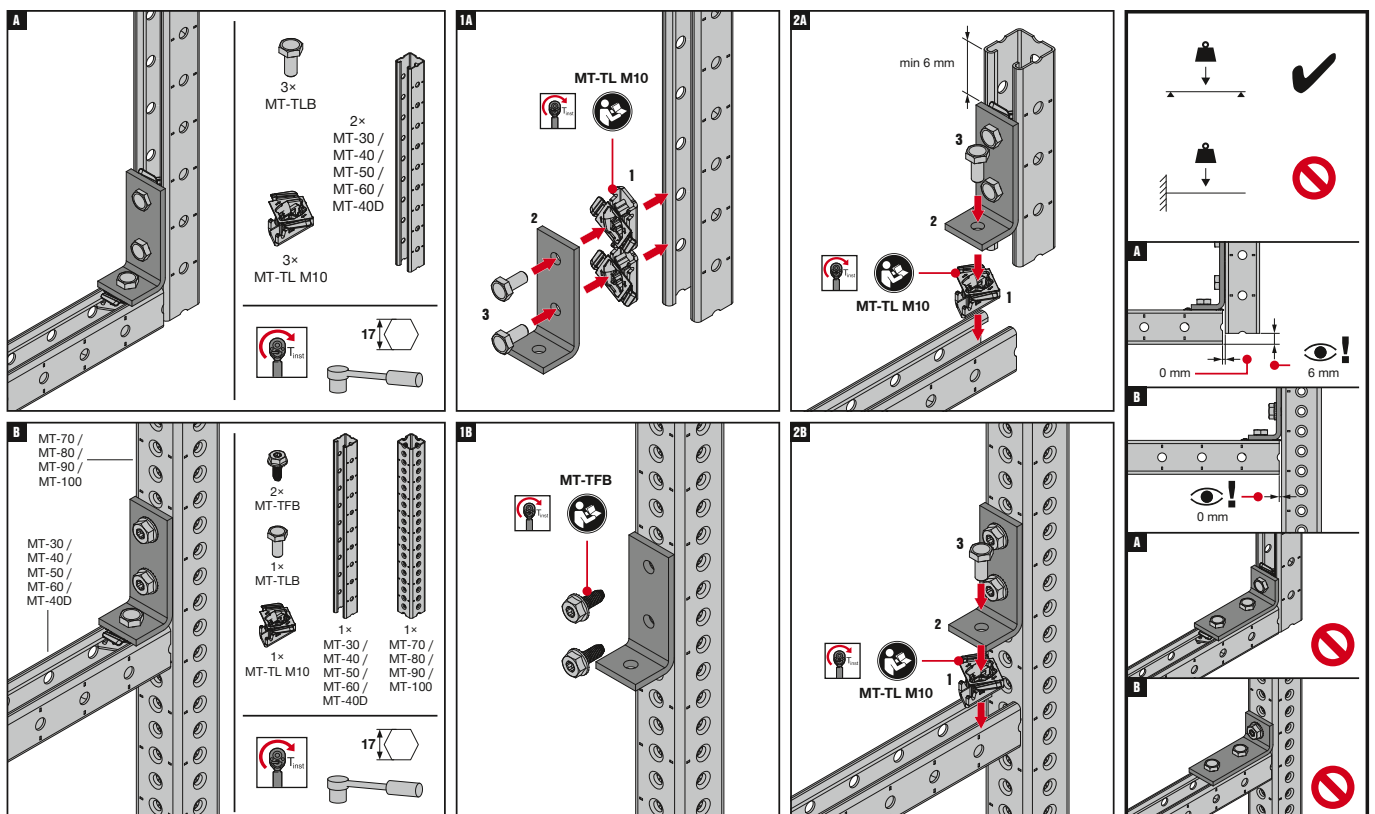

The latest IFU (Instruction for Use) is available on Hilti Online. Please check for any revisions before installing the product.

MT Open C-Channel Connectors

90° Connectors

Operation Instruction

MT-C-LL1 / MT-C-LL1 OC

2288324-09.2020

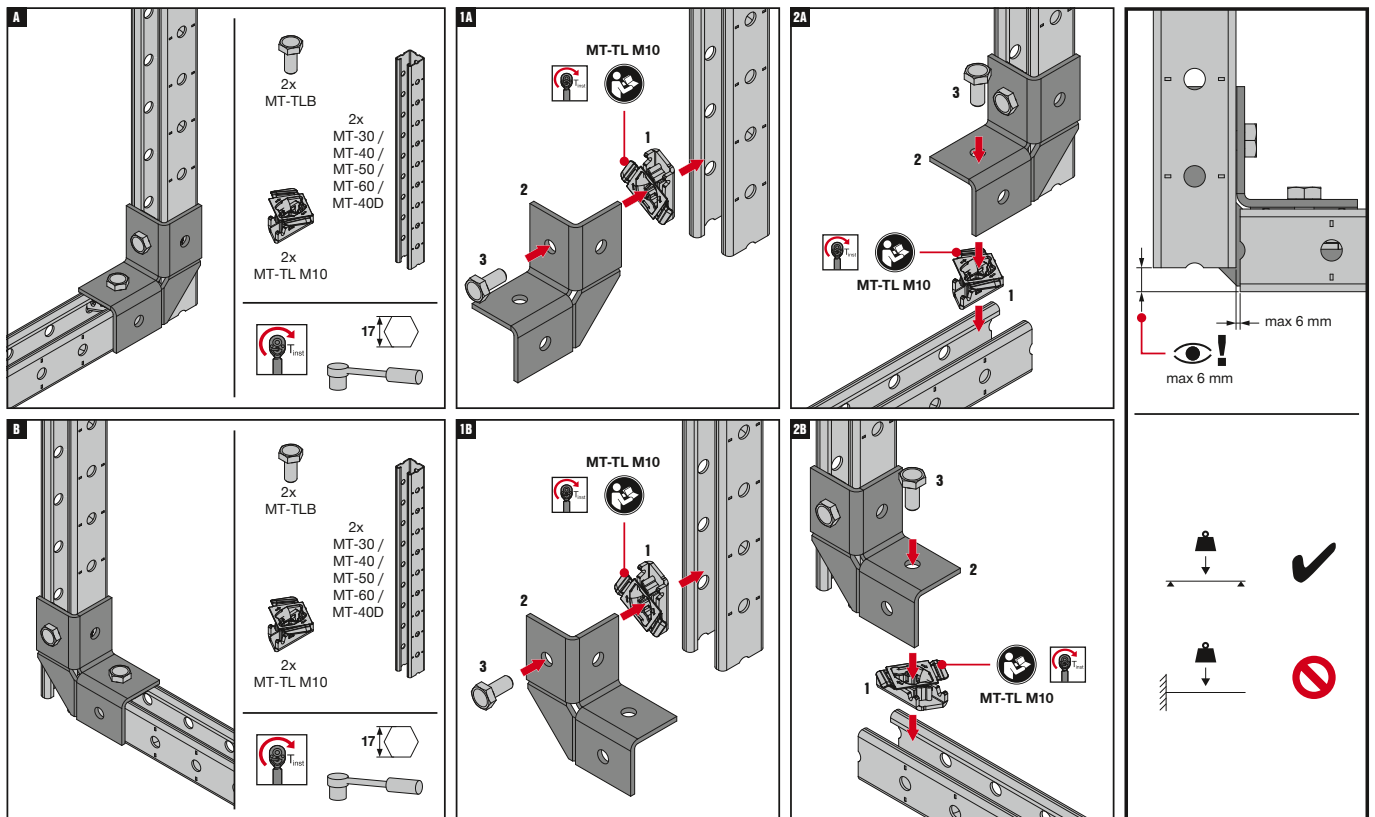

The latest IFU (Instruction for Use) is available on Hilti Online. Please check for any revisions before installing the product.

MT-C-LL2 / MT-C-LL2 OC

2288325-06.2020

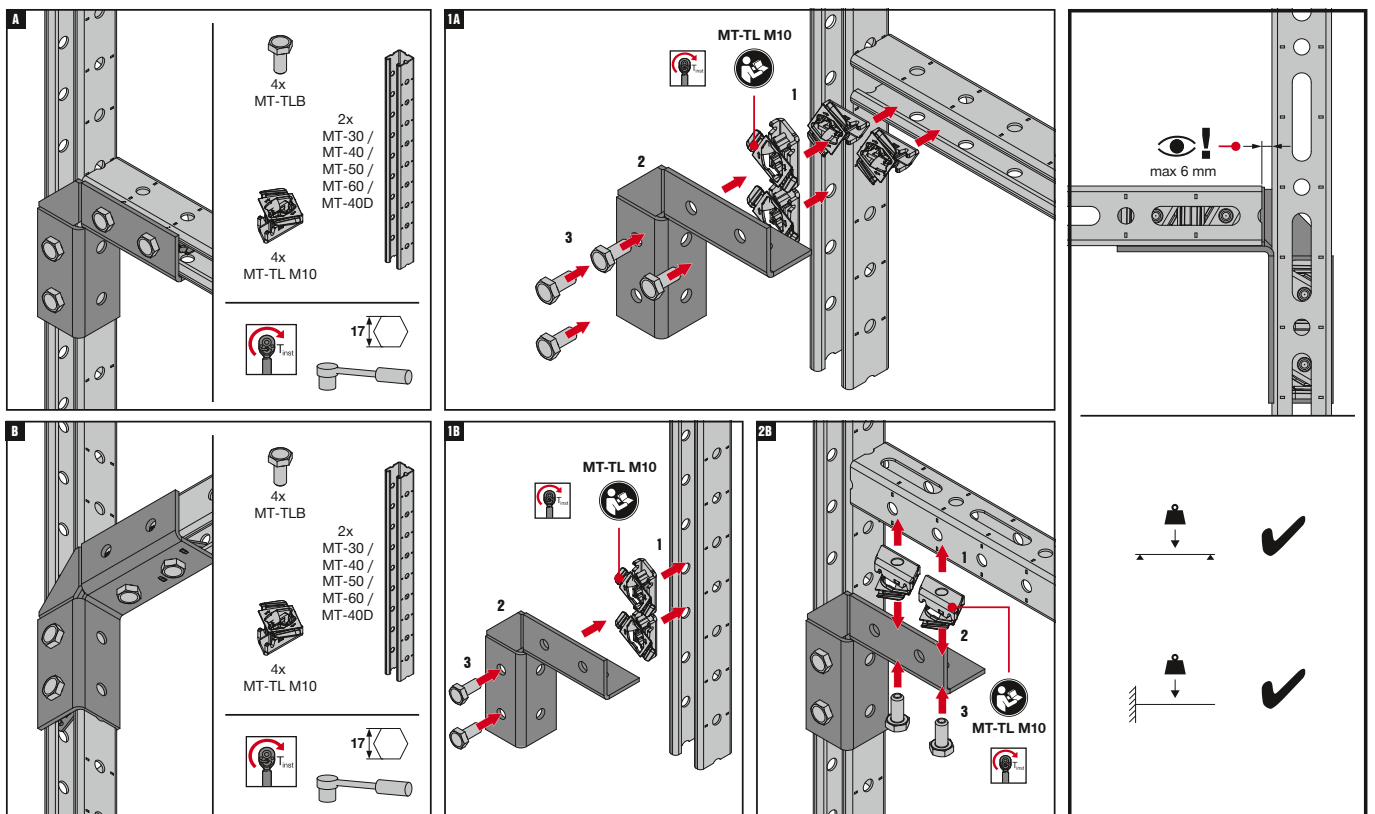

The latest IFU (Instruction for Use) is available on Hilti Online. Please check for any revisions before installing the product.

MT Open C-Channel Connectors

Channel Ties

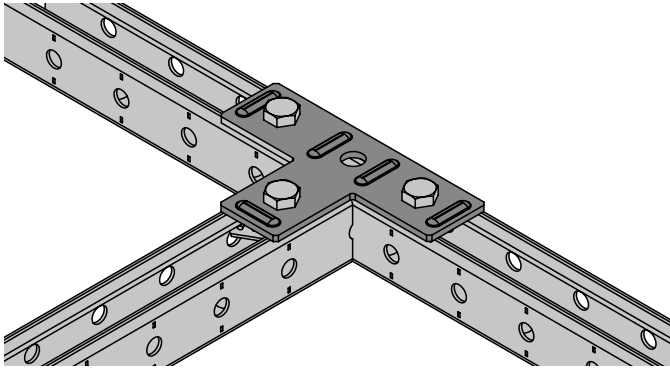

Applications

- Connecting two MT C-Channels together
- Compatible with multiple MT C-Channels
- Suitable for use in dry, indoor environments

Advantages

- Adjustable – easily fit and repositioned along C-Channels
- Compatible with Twist-Lock Channel Connectors – for much faster, adaptable assembly

Technical Data

Material composition	Q235 or better steel
Surface finish	Indoor Coated - Electro galvanized

MT-CT-H2 Channel Tie

Order Designation	Technical Data	Sales pack quantity	Item number	
MT-CT-H2	Dry indoor conditions (C1) Indoor with temporary condensation (C2)	15 pc	2322405	

MT-CT-H4 Channel Tie

Order Designation	Technical Data	Sales pack quantity	Item number	
MT-CT-H4	Dry indoor conditions (C1) Indoor with temporary condensation (C2)	15 pc	2322408	

MT Open C-Channel Connectors

Channel Ties

4

MT-CT-H5 Channel Tie

Order Designation	Technical Data	Sales pack quantity	Item number	
MT-CT-H5	Dry indoor conditions (C1) Indoor with temporary condensation (C2)	8 pc	2322406	

MT-CT-T Channel Tie

Order Designation	Technical Data	Sales pack quantity	Item number	
MT-CT-T	Dry indoor conditions (C1) Indoor with temporary condensation (C2)	12 pc	2322407	

MT Open C-Channel Connectors

4

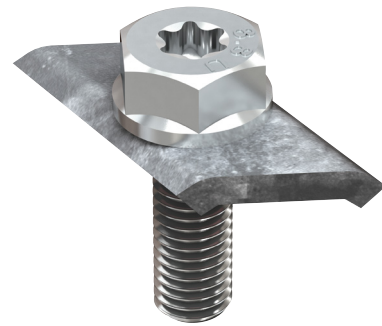
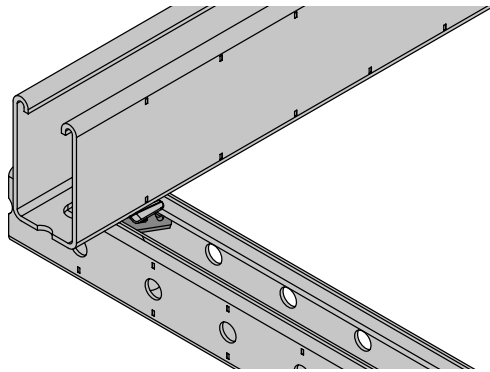

Applications

- Fastening horizontal MT C-Channel to vertical MT Box Profiles, such as for integrated raised floors in data centers
- Suitable for use in dry, indoor environments

Advantages

- Part of the Hilti MT system – an economical, all-in-one solution for virtually all modular MEP support structures
- To be used with the MT-C-T A Connector

Technical Data

Material composition	see detailed table
Surface finish	see detailed table

MT-C-T A Connector

Order Designation	Material composition	Surface finish	Technical Data	Sales pack quantity	Item number	
MT-C-T A	Q355 or better steel	Pre-galvanized - for dry indoor use only	Dry indoor conditions (C1) Indoor with temporary condensation (C2)	20 pc	2272056	

MT-CTAB Connector Bolt

Order Designation	Material composition	Surface finish	Technical Data	Sales pack quantity	Item number	
MT-CTAB	Q355 or better steel	Indoor Coated - Electro galvanized	Dry indoor conditions (C1) Indoor with temporary condensation (C2)	100pc	2332797	

MT Open C-Channel Connectors - Outdoor Channel Ties

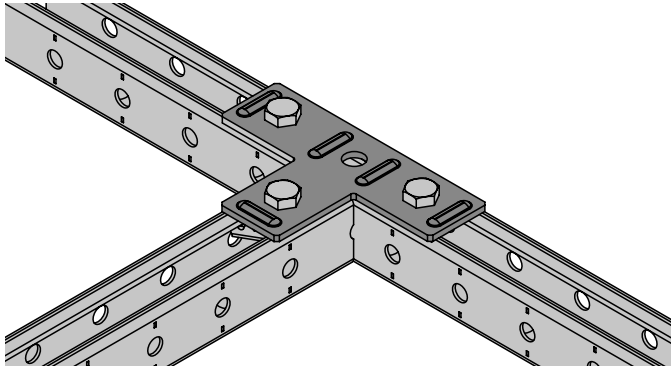

Applications

- Connecting two MT C-Channels together
- Suitable for use in moderately corrosive environments

Advantages

- Adjustable – easily fit and repositioned along C-Channels
- Compatible with Twist-Lock Channel Connectors – for much faster, adaptable assembly

Technical Data

Material composition	Q235 or better steel
Surface finish	Outdoor Coated - HDG

MT-CT-H2 OC Channel Tie - Outdoor

Order Designation	Technical Data	Sales pack quantity	Item number	
MT-CT-H2 OC	Outdoor, low to moderate pollution (C3 / C4 - low)	15 pc	2322409	

MT-CT_H4 OC Channel Tie - Outdoor

Order Designation	Technical Data	Sales pack quantity	Item number	
MT-CT-H4 OC	Outdoor, low to moderate pollution (C3 / C4 - low)	15 pc	2322412	

MT Open C-Channel Connectors - Outdoor Channel Ties

4

MT-CT-T OC Channel Tie - Outdoor

Order Designation	Technical Data	Sales pack quantity	Item number	
MT-CT-T OC	Outdoor, low to moderate pollution (C3 / C4 - low)	12 pc	2322411	

MT-CT-H5 OC Channel Tie - Outdoor

Order Designation	Technical Data	Sales pack quantity	Item number	
MT-CT-H5 CO	Outdoor, low to moderate pollution (C3 / C4 - low)	8 pc	2322410	

MT Open C-Channel Connectors

Connectors - Outdoor

4

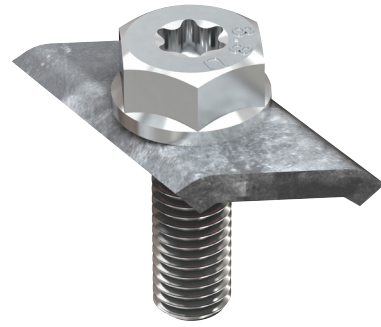
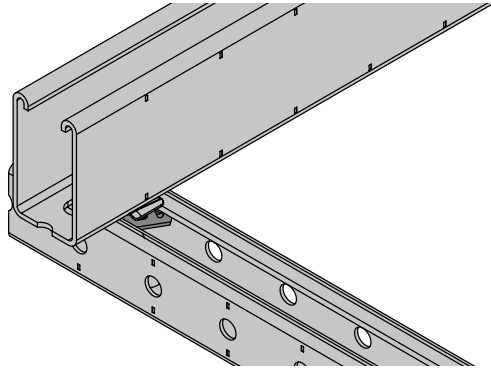

Applications

- Connecting two MT C-Channels together
- Suitable for use in moderately corrosive environments

Advantages

- Adjustable – easily fit and repositioned along C-Channels
- To be used with the MT-C-T A Connector

Technical Data

Material composition	Q235 or better steel
Surface finish	Outdoor Coated - HDG

MT-C-T A OC Connector - Outdoor

Order Designation	Material composition	Technical Data	Sales pack quantity	Item number	
MT-C-T A OC	Q355B - GB/T 700	Outdoor, low to moderate pollution (C3 / C4 - low)	20 pc	2272057	

MT-CTAB OC Connector Bolt - Outdoor

Order Designation	Material composition	Technical Data	Sales pack quantity	Item number	
MT-CTAB OC	Q235 or better steel	Outdoor, low to moderate pollution (C3 / C4 - low)	100 pc	2332788	

MT Open C-Channel Connectors

Channel Ties

4

Technical Data MT Channel Ties

Item image	Load drawing	Order Designation	+ Fz	± Fx	± Fy
		MT-CT-H2 / MT-CT-H2 OC	1,8 kN	2,6 kN	1,8 kN
		MT-CT-H4 / MT-CT-H4 OC	5,7 kN	5,0 kN	3,6 kN
		MT-CT-H5 / MT-CT-H5 OC	2,6 kN	3,4 kN	3,4 kN
		MT-CT-T / MT-CT-T OC	2,3 kN	5,1 kN	1,6 kN

Design notes

- Shown load values are recommended values with partial safety factors for actions and resistance included
- Design value = 1.4 * recommended value
- The design resistance of the products is defined in accordance with EN1993

Technical Data MT Channel Connector

Item image	Load drawing	Order Designation	+ Fz	- Fz	± Fx	± Fy
		MT-C-T A / MT-C-T A OC	2,0 kN	2,0 kN	10,0 kN	2,0 kN

Design notes

- Shown load values are recommended values with partial safety factors for actions and resistance included
- Design value = 1.4 * recommended value
- The design resistance of the products is defined in accordance with EN1993

MT Open C-Channel Connectors

Channel Ties

4

Operation Instruction

MT-CT-H2

2325257-04.2021

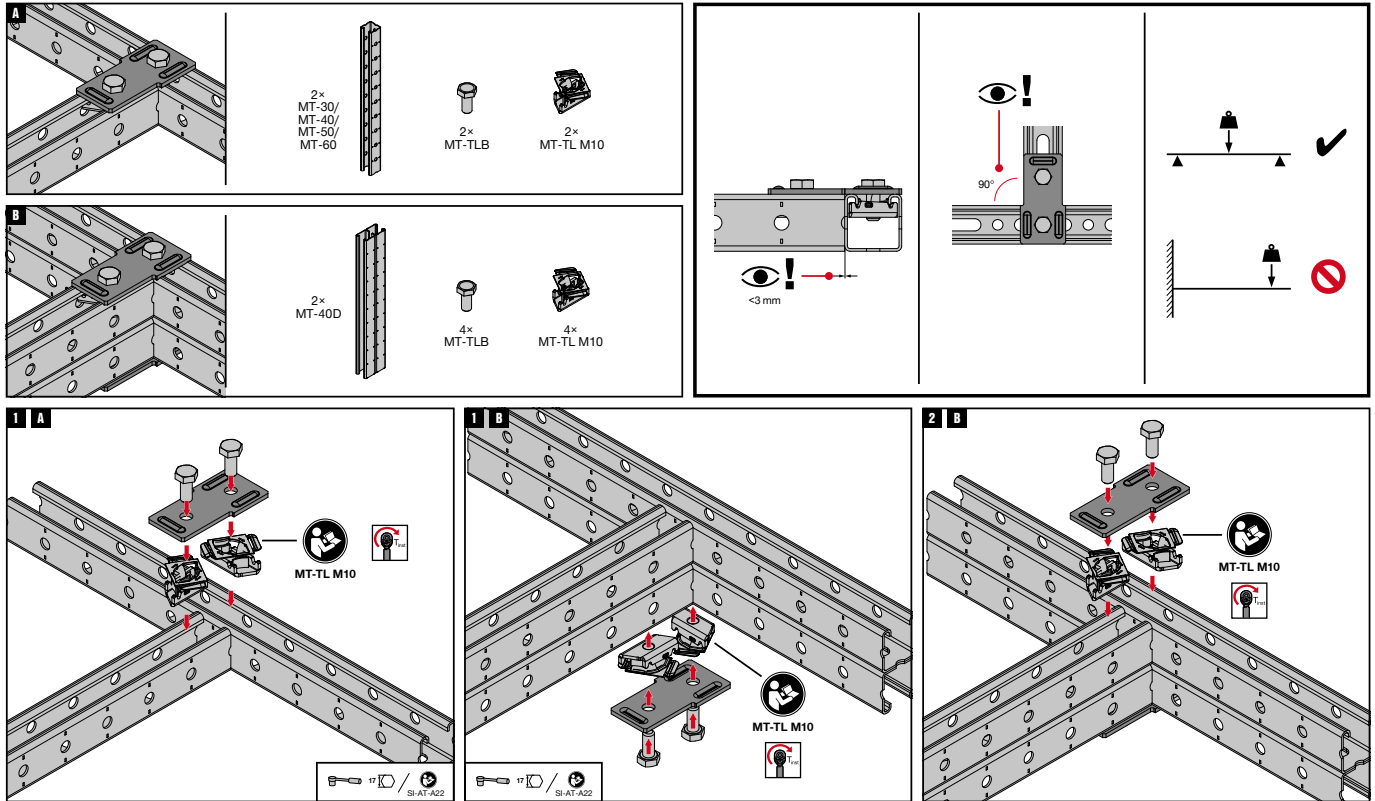

The latest IFU (Instruction for Use) is available on Hilti Online. Please check for any revisions before installing the product.

MT-CT-H4

2327511-04.2021

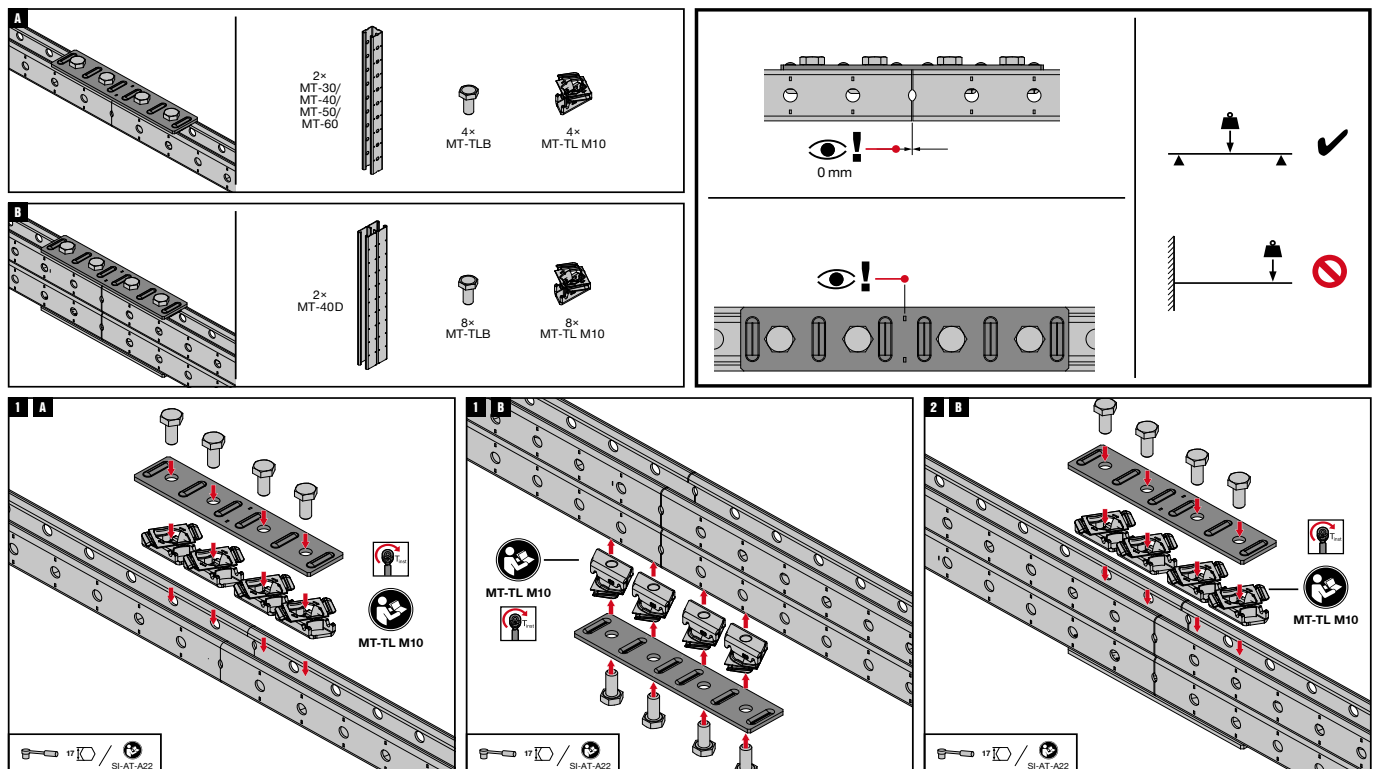

The latest IFU (Instruction for Use) is available on Hilti Online. Please check for any revisions before installing the product.

MT Open C-Channel Connectors

Channel Ties

4

Operation Instruction MT-CT-H5

2325301-04.2021

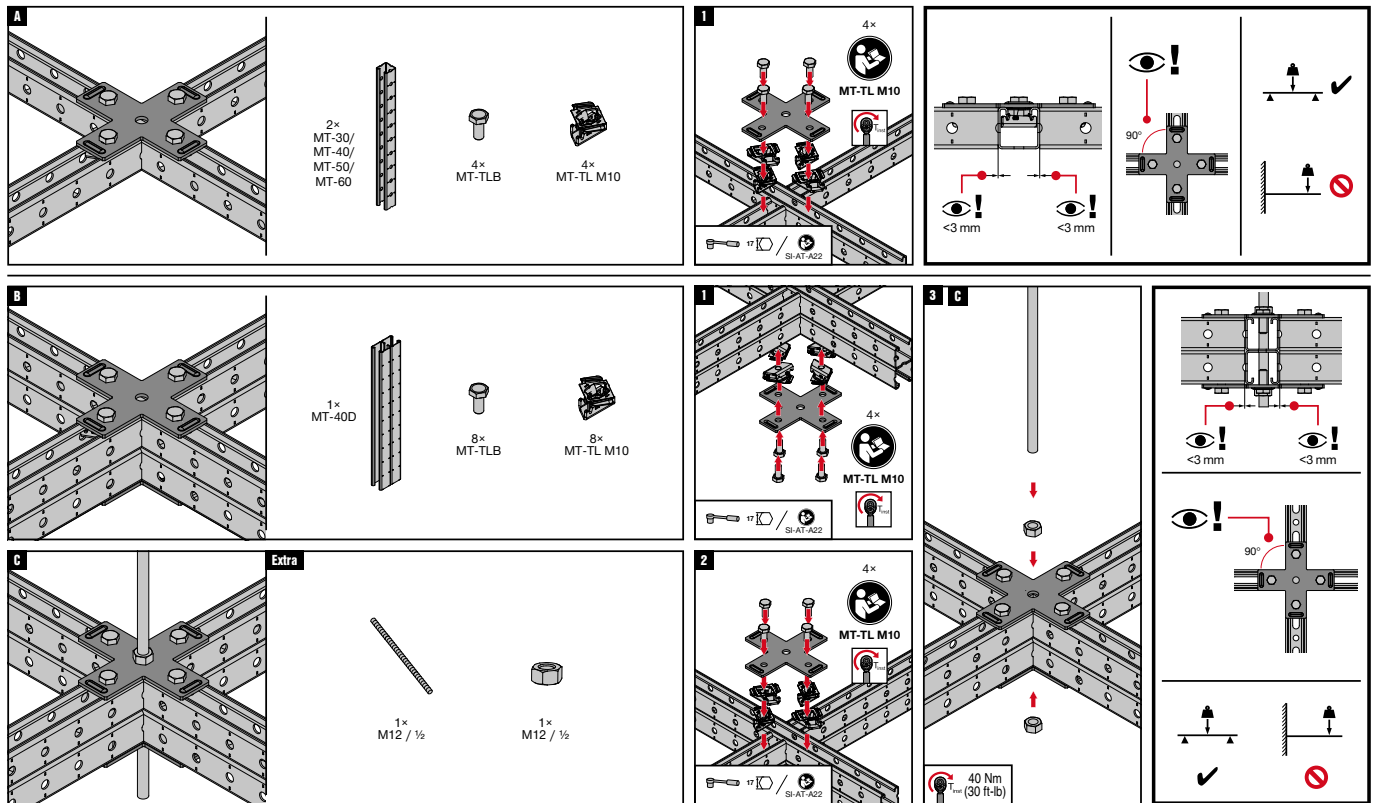

The latest IFU (Instruction for Use) is available on Hilti Online. Please check for any revisions before installing the product.

Operation Instruction MT-CT-T

2325310-04.2021

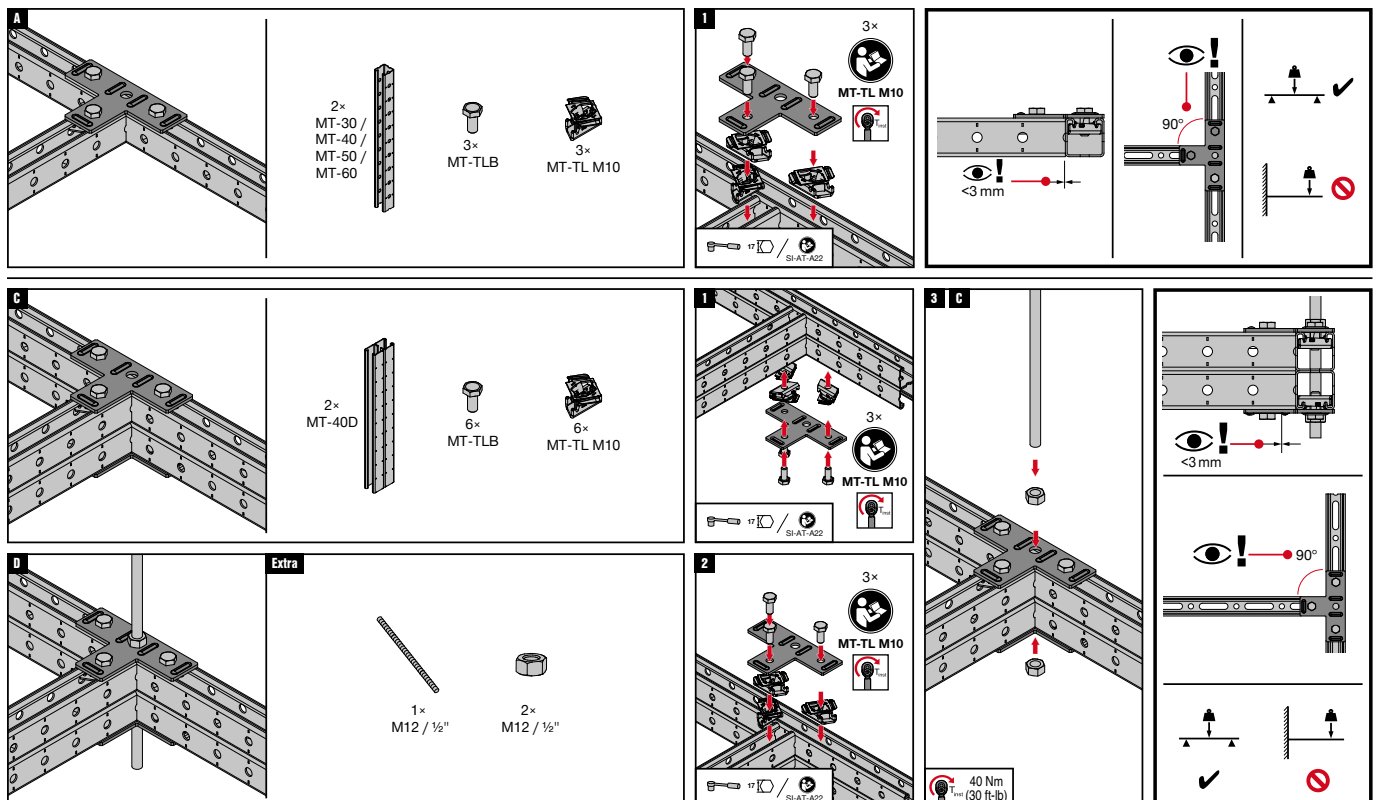

The latest IFU (Instruction for Use) is available on Hilti Online. Please check for any revisions before installing the product.

MT Open C-Channel Connectors

4

Operation Instruction MT-C-T A / MT-C-T A OC

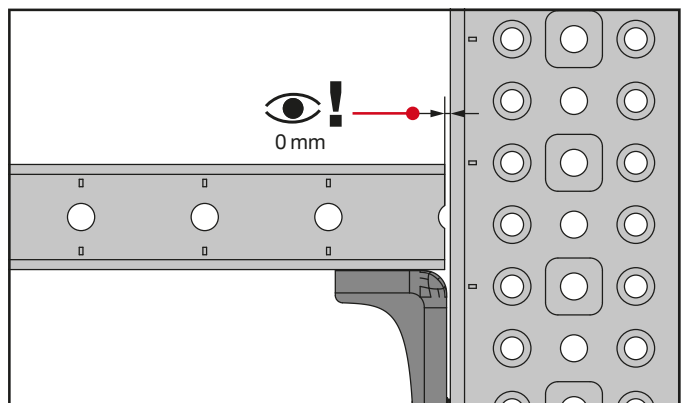
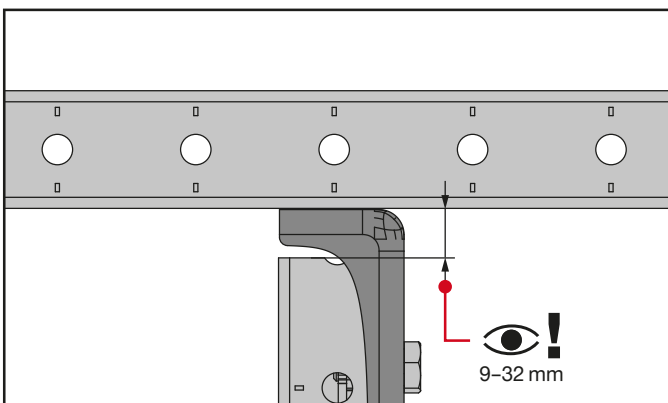
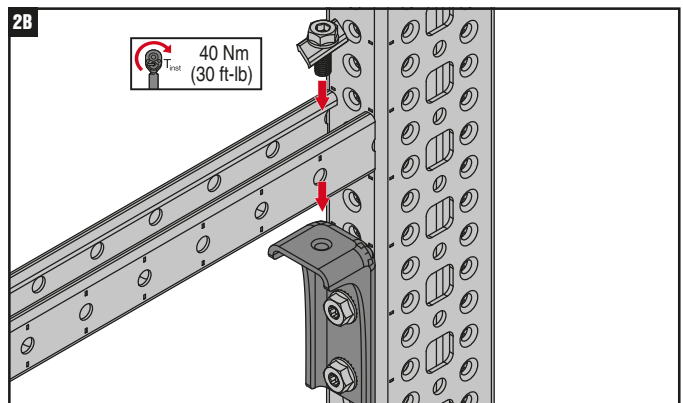
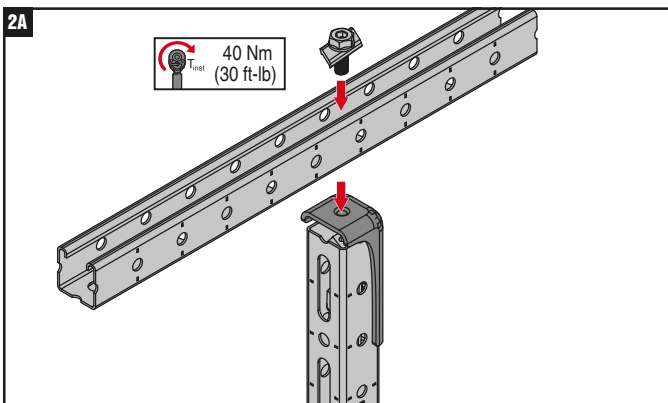
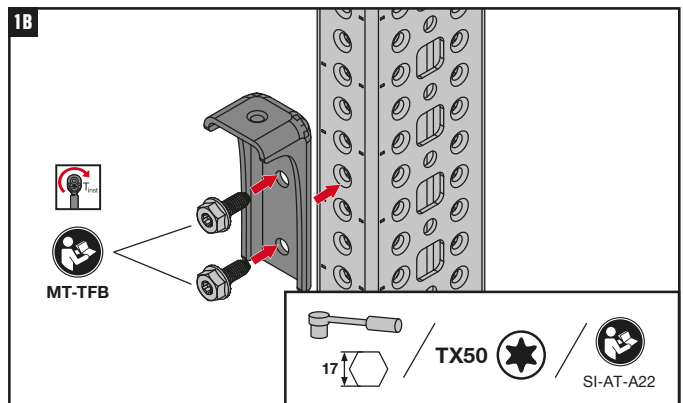
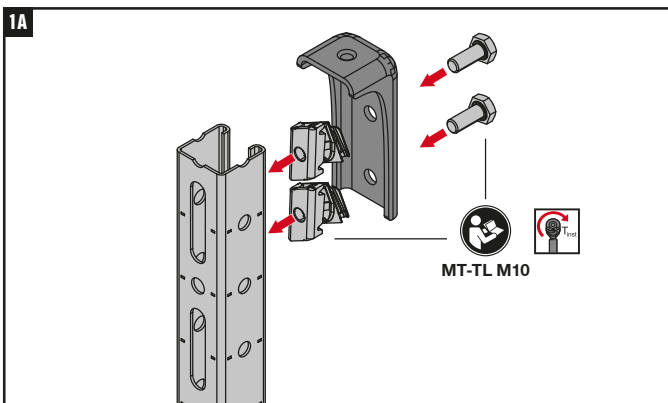
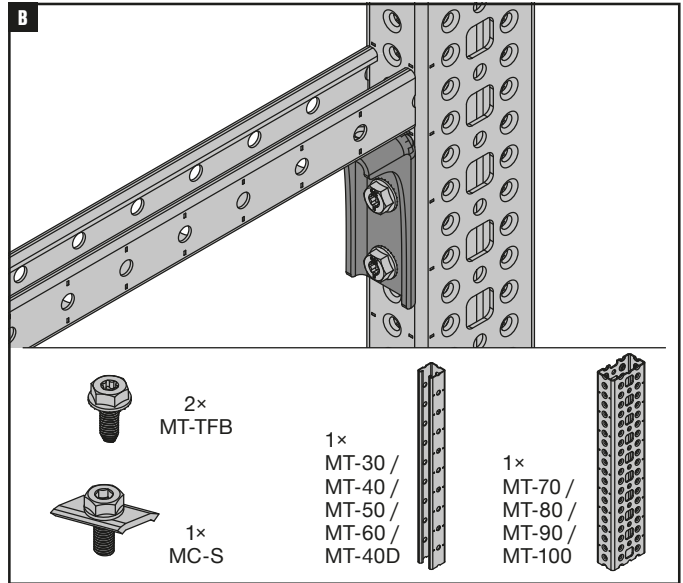
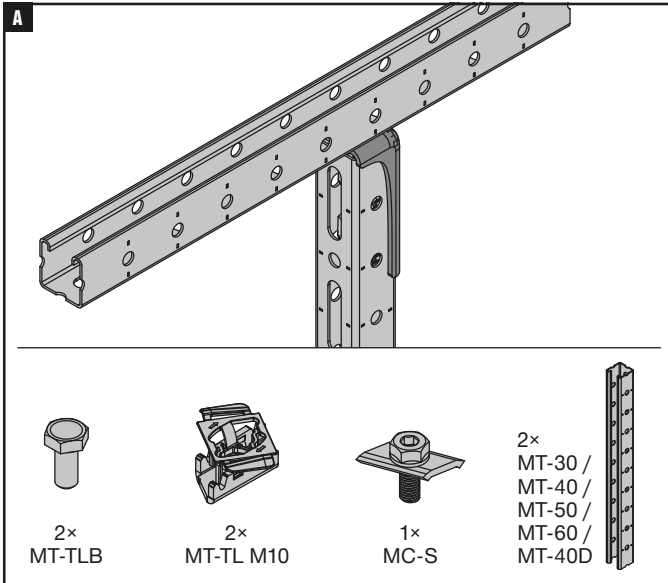

The latest IFU (Instruction for Use) is available on Hilti Online. Please check for any revisions before installing the product.

MT Open C-Channel Connectors

4

Operation Instruction MT-CTAB / MT-CTAB OC

2334482-07_2021

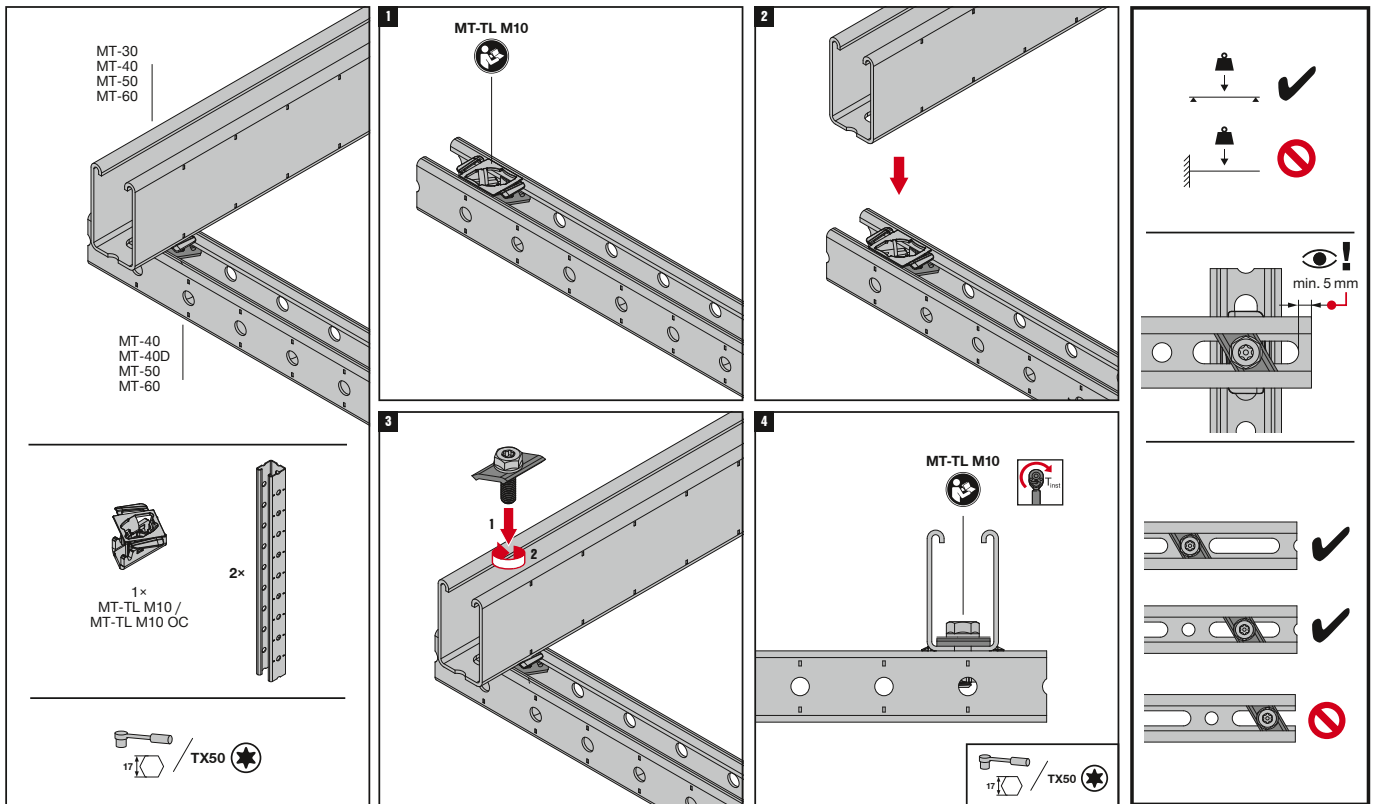

The latest IFU (Instruction for Use) is available on Hilti Online. Please check for any revisions before installing the product.

MT Open C-Channel Connectors

Splice Connectors

4

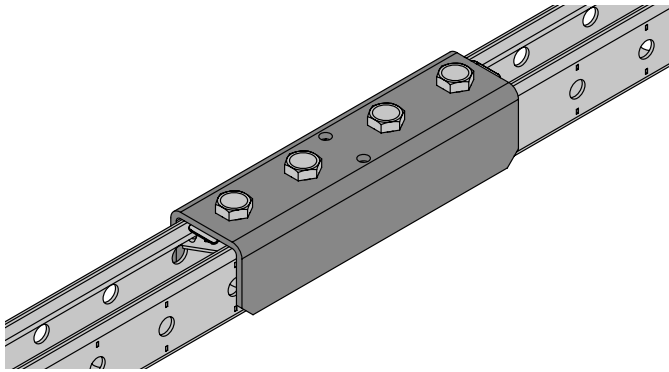

Applications

- Extending MT C-Channels by fastening them together end-to-end
- Assembling metal framing for MEP support structures when longer spans or increased floor/ceiling clearance are required
- Suitable for use in dry, indoor environments

Advantages

- Part of the Hilti MT system – an economical, all-in-one solution for virtually all modular MEP support structures
- Easy to install – compatible with the Hilti MT Twist-Lock, a faster alternative to spring nuts for assembling a modular support system
- Adaptable – unlike welding, angle Brackets allow you to modify C-Channel framing during installation and for future MEP requirements

Technical Data

Material composition	Q235 or better steel
Surface finish	Pre-galvanized - for dry indoor use only

MT-ES-40 Splice Connector

Order Designation	Technical Data	Sales pack Quantity	Item number	
MT-ES-40	Dry indoor conditions (C1) Indoor with temporary condensation (C2)	12 pc	2272062	

MT-ES-60 Splice Connector

Order Designation	Technical Data	Sales pack Quantity	Item number	
MT-ES-60	Dry indoor conditions (C1) Indoor with temporary condensation (C2)	8 pc	2322415	

MT Open C-Channel Connectors

Splice Connectors - Outdoor

4

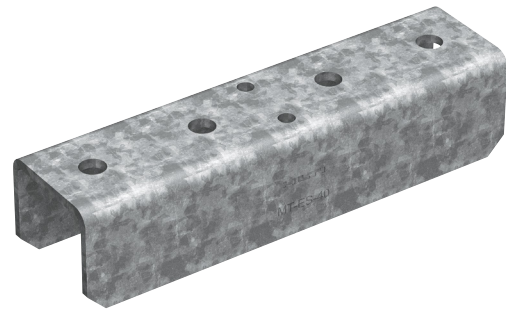
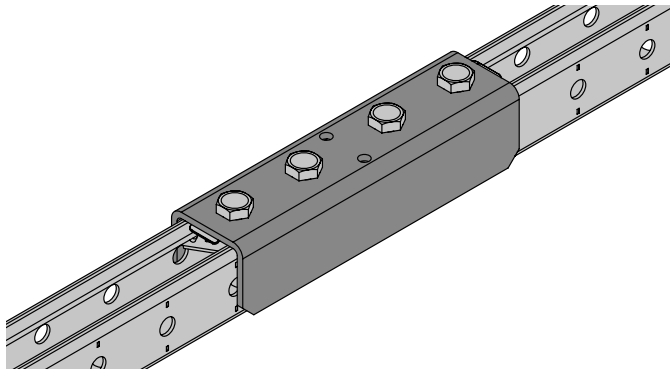

Applications

- Extending MT C-Channels by fastening them together end-to-end
- Assembling metal framing for MEP support structures when longer spans or increased floor/ceiling clearance are required
- Suitable for use in moderately corrosive environments

Advantages

- Part of the Hilti MT system – an economical, all-in-one solution for virtually all modular MEP support structures
- Easy to install – compatible with the Hilti MT Twist-Lock, a faster alternative to spring nuts for assembling a modular support system
- Adaptable – unlike welding, angle Brackets allow you to modify C-Channel framing during installation and for future MEP requirements

Technical Data

Material composition	Q235 or better steel
Surface finish	Hot-dip galvanized - for outdoor use

MT-ES-40 OC Splice Connector - Outdoor

Order Designation	Technical Data	Sales pack Quantity	Item number	
MT-ES-40 OC	Outdoor, low to moderate pollution (C3 / C4 - low)	12 pc	2272063	

MT-ES-60 OC Splice Connector - Outdoor

Order Designation	Technical Data	Sales pack Quantity	Item number	
MT-ES-60 OC	Outdoor, low to moderate pollution (C3 / C4 - low)	8 pc	2322416	

MT Open C-Channel Connectors

Splice Connectors

4

Technical Data MT Splice Connector

Item image	Load drawing	Order Designation	+ Fz	- Fz	± Fx	± Fy	± My
		MT-ES-40 / MT-ES-40 OC	10,0 kN	10,0 kN	10,0 kN	0,6 kN	0,3 kNm
		MT-ES-60 / MT-ES-60 OC	4,3 kN	3,9 kN	10,0 kN	1,1 kN	

Design notes

- Shown load values are recommended values with partial safety factors for actions and resistance included
- Design value = 1.4 * recommended value
- The design resistance of the products is defined in accordance with EN1993

MT Open C-Channel Connectors

Splice Connectors

4

Operation Instruction

MT-ES-40 / MT-ES-40 OC

2288189-06.2020

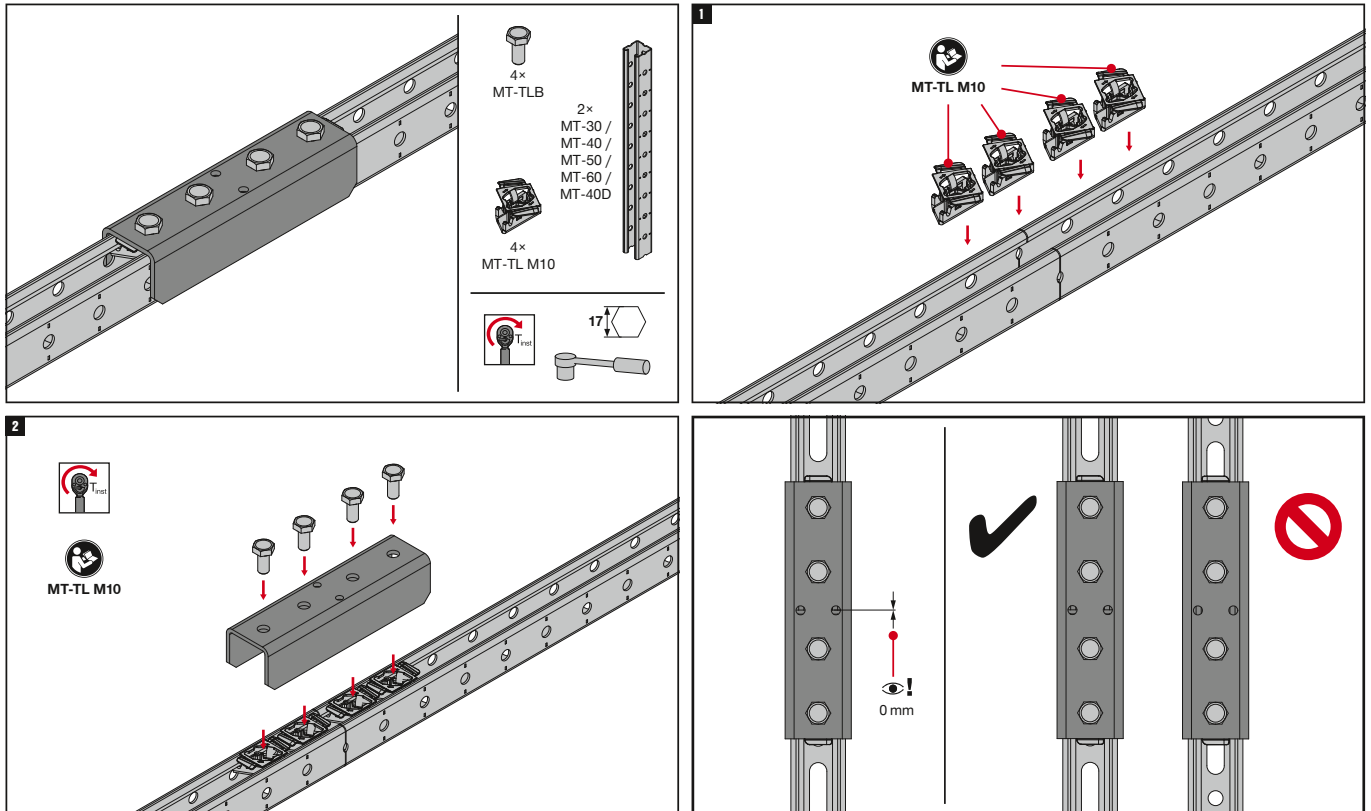

The latest IFU (Instruction for Use) is available on Hilti Online. Please check for any revisions before installing the product.

MT-ES-60

2325098-04.2021

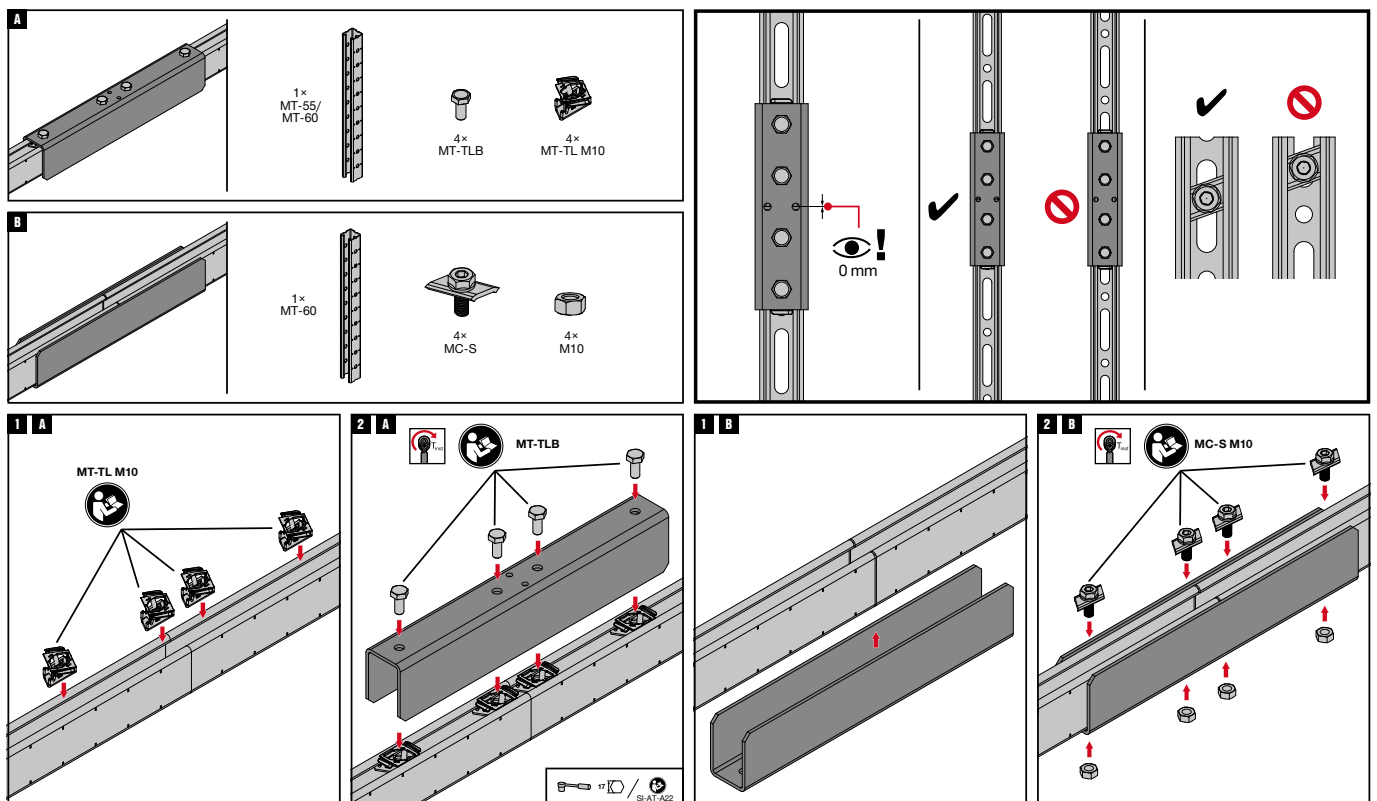

The latest IFU (Instruction for Use) is available on Hilti Online. Please check for any revisions before installing the product.

MT Open C-Channel Connectors

Long Span Bracing

4

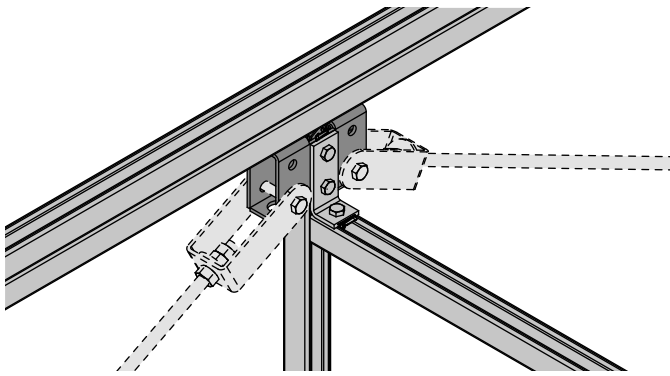

Applications

- Assembling and bracing modular support structures with longer spans

Advantages

- High load capacity – designed for threaded rod bracing for increased rigidity over long spans
- Part of the Hilti MT system – an economical, all-in-one solution for virtually all modular MEP support structures

Technical Data

Material composition	Q235 or better steel
Surface finish	Indoor Coated - Electro galvanized

MT-C-LS Connector

Order Designation	Technical Data	Sales pack Quantity	Item number	
MT-C-LS	Dry indoor conditions (C1) Indoor with temporary condensation (C2)	10 pc	2322419	

MT Open C-Channel Connectors

Long Span Bracing

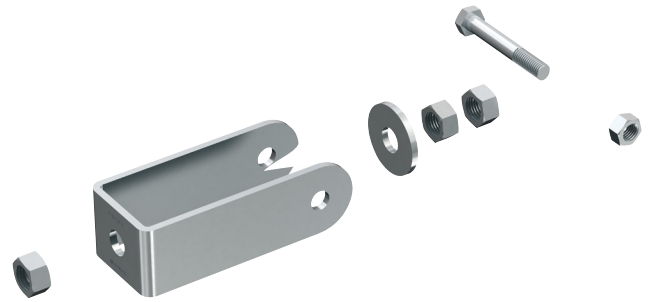
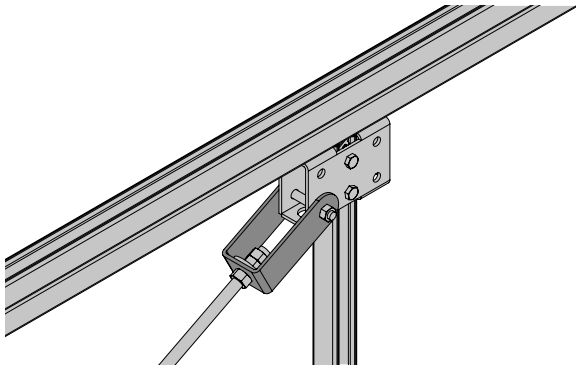

Applications

- Bracing modular support structures with longer spans

Advantages

- High load capacity – designed for threaded rod bracing for increased rigidity over long spans
- Part of the Hilti MT system – an economical, all-in-one solution for virtually all modular MEP support structures

Technical Data

Material composition	Q235 or better steel
Surface finish	Indoor Coated - Electro galvanized

MT-FTR-LS Brace Connector

Order Designation	Technical Data	Sales pack Quantity	Item number	
MT-FTR-LS	Dry indoor conditions (C1) Indoor with temporary condensation (C2)	1 pc	2322421	

Technical Data Long span bracing

Item image	Load drawing	Order Designation	+ Fz	- Fz	± Fx	± Fy
		MT-C-LS + MT-FTR-LS	-	-	10,0 kN	-

- Design notes**
- Shown load values are recommended values with partial safety factors for actions and resistance included
 - Design value = 1.4 * recommended value
 - The design resistance of the products is defined in accordance with EN1993

MT Open C-Channel Connectors

Long Span Bracing

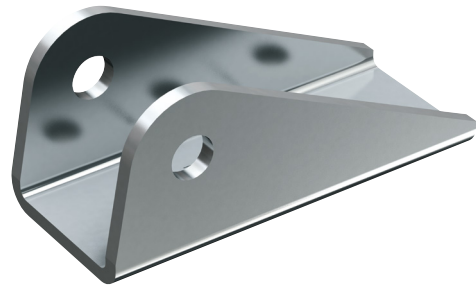
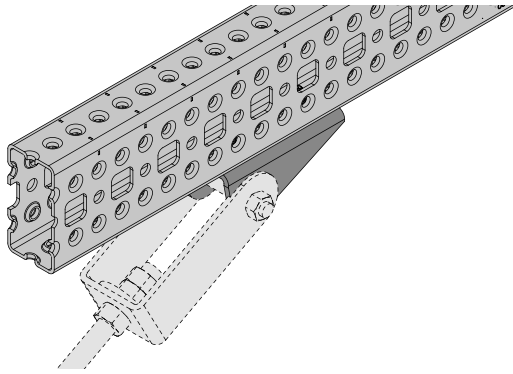

Applications

- Assembling and bracing modular support structures with longer spans

Technical Data

Material composition	Q235 or better steel
Surface finish	Indoor Coated - Electro galvanized

Advantages

- High load capacity – designed for threaded rod bracing for increased rigidity over long spans
- Part of the Hilti MT system – an economical, all-in-one solution for virtually all modular MEP support structures

MT-AB-LS Brace Connector

Order Designation	Profile	Technical Data	Sales pack Quantity	Item number	
MT-AB-LS	MT-40D OC MT-70 MT-80	Dry indoor conditions (C1) Indoor with temporary condensation (C2)	24 pc	2322420	

MT Open C-Channel Connectors

Long Span Bracing - Outdoor

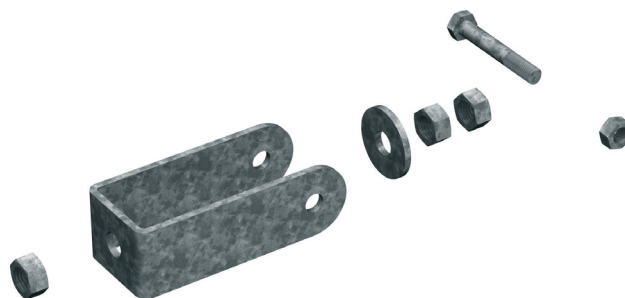
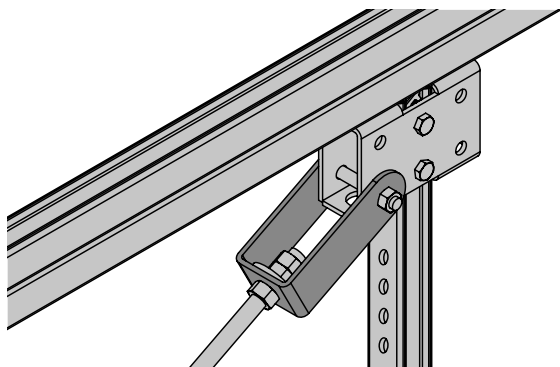

Applications

- Bracing modular support structures with longer spans

Advantages

- High load capacity – designed for threaded rod bracing for increased rigidity over long spans
- Part of the Hilti MT system – an economical, all-in-one solution for virtually all modular MEP support structures
- Corrosion resistance – hot-dip galvanized to help protect against moisture and chemical corrosion

Technical Data

Material composition	Q235 or better steel
Surface finish	Outdoor Coated - HDG

MT-FTR-LS OC Brace Connector - Outdoor

Order Designation	Technical Data	Sales pack Quantity	Item number	
MT-FTR-LS OC	Outdoor, low to moderate pollution (C3 / C4 - low)	1 pc	2322424	

Technical Data Long span bracing

Item image	Load drawing	Order Designation	+ Fz	- Fz	± Fx	± Fy
		MT-C-LS + MT-FTR-LS	-	-	10,0 kN	-

Design notes

- Shown load values are recommended values with partial safety factors for actions and resistance included
- Design value = 1.4 * recommended value
- The design resistance of the products is defined in accordance with EN1993

MT Open C-Channel Connectors
Long Span Bracing - Outdoor

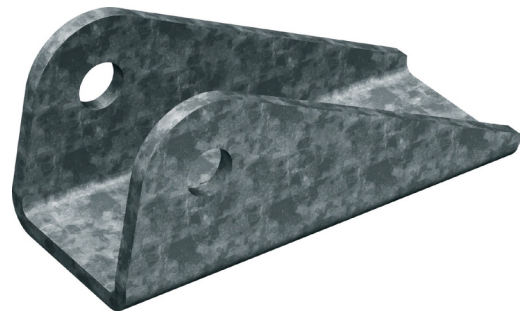
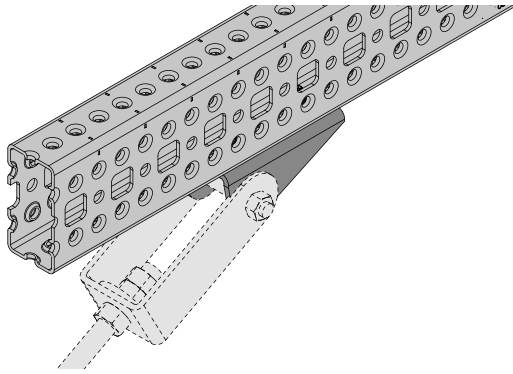

Applications

- Assembling and bracing modular support structures with longer spans

Advantages

- High load capacity – enables threaded rod bracing for increased rigidity over long spans
- Corrosion resistance – hot-dip galvanized to help protect against moisture and chemical corrosion
- Part of the Hilti MT system – an economical, all-in-one solution for virtually all modular MEP support structures

Technical Data

Material composition	Q235 or better steel
Surface finish	Outdoor Coated - HDG

MT-AB-LS OC Brace Connector - Outdoor

Order Designation	Technical Data	Sales pack Quantity	Item number
MT-AB-LS OC	Outdoor, low to moderate pollution (C3 / C4 - low)	24 pc	2322423

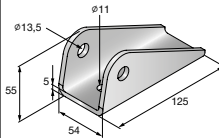

MT Open C-Channel Connectors

Long Span Bracing

4

Operation Instruction MT-C-LS / MT-C-LS OC

2325258-04.2021

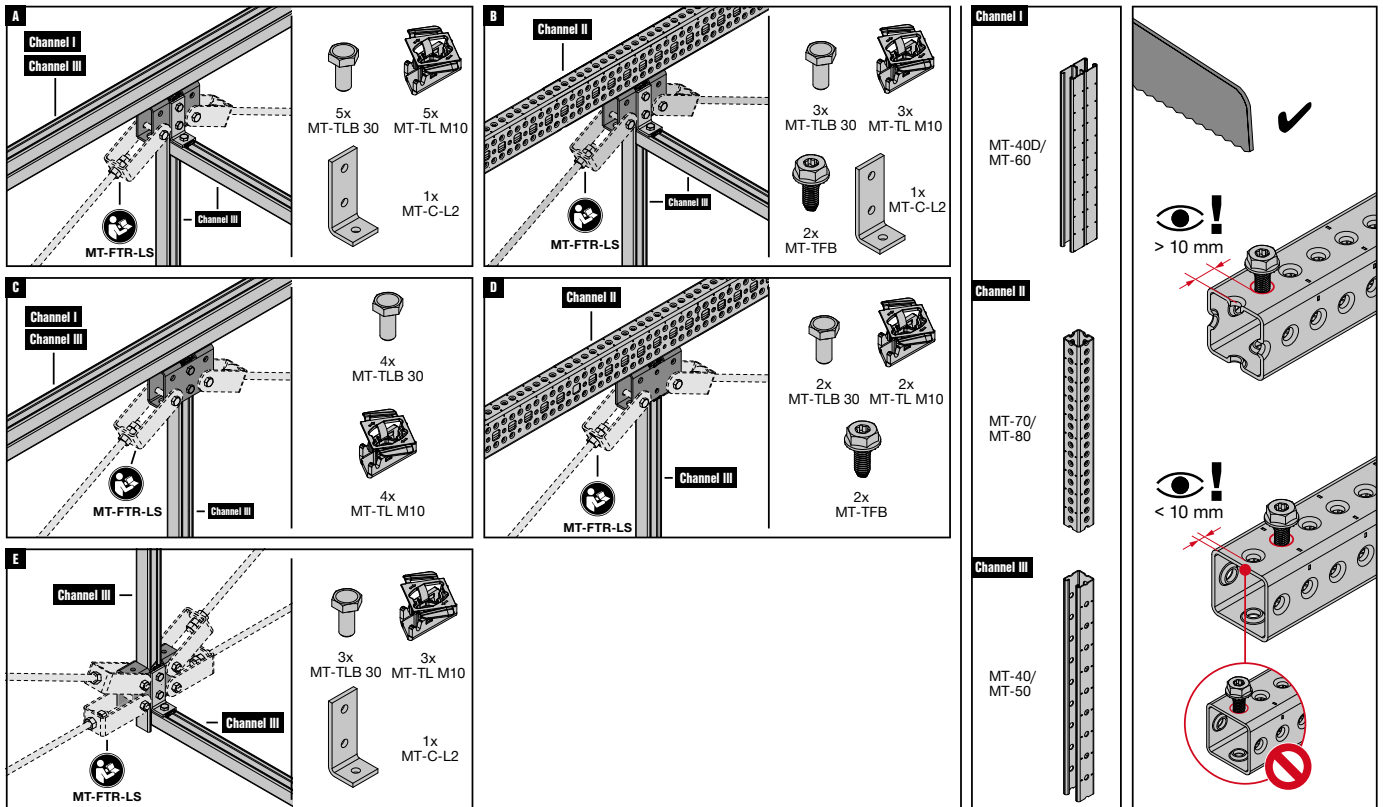

The latest IFU (Instruction for Use) is available on Hilti Online. Please check for any revisions before installing the product.

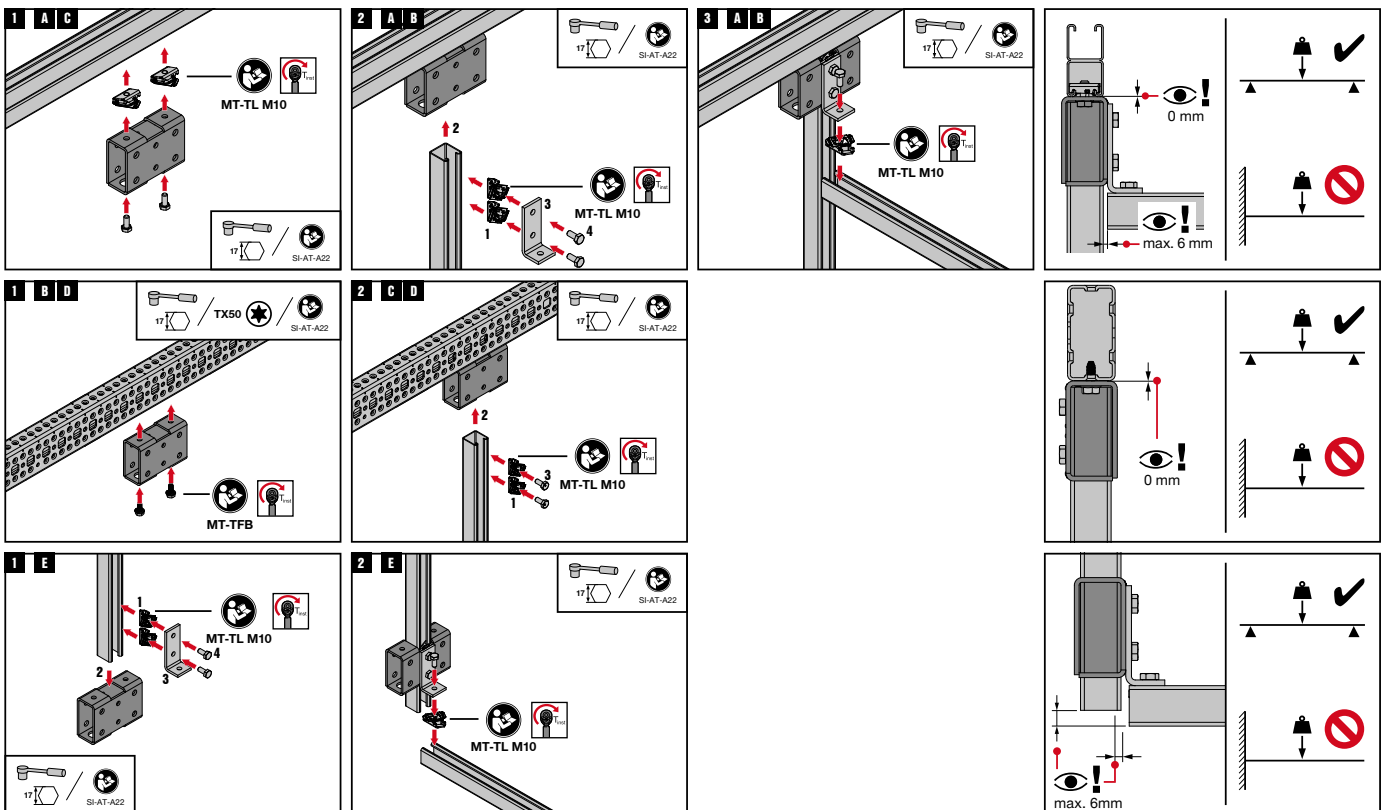

The latest IFU (Instruction for Use) is available on Hilti Online. Please check for any revisions before installing the product.

MT Open C-Channel Connectors

Long Span Bracing

Operation Instruction

MT-FTR-LS / MT-FTR-LS OC

2325259-04.2021

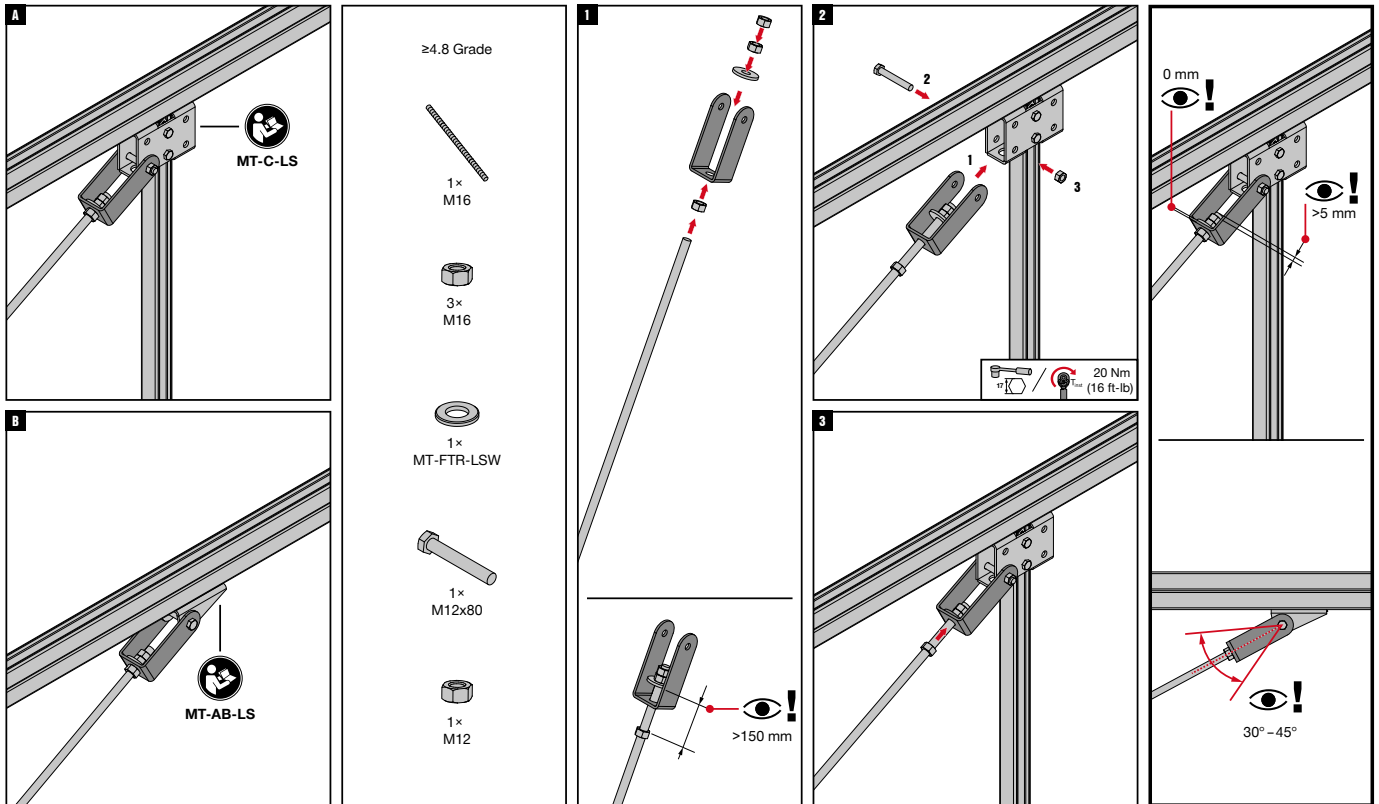

The latest IFU (Instruction for Use) is available on Hilti Online. Please check for any revisions before installing the product.

MT-AB-LS / MT-AB-LS OC

2325231-04.2021

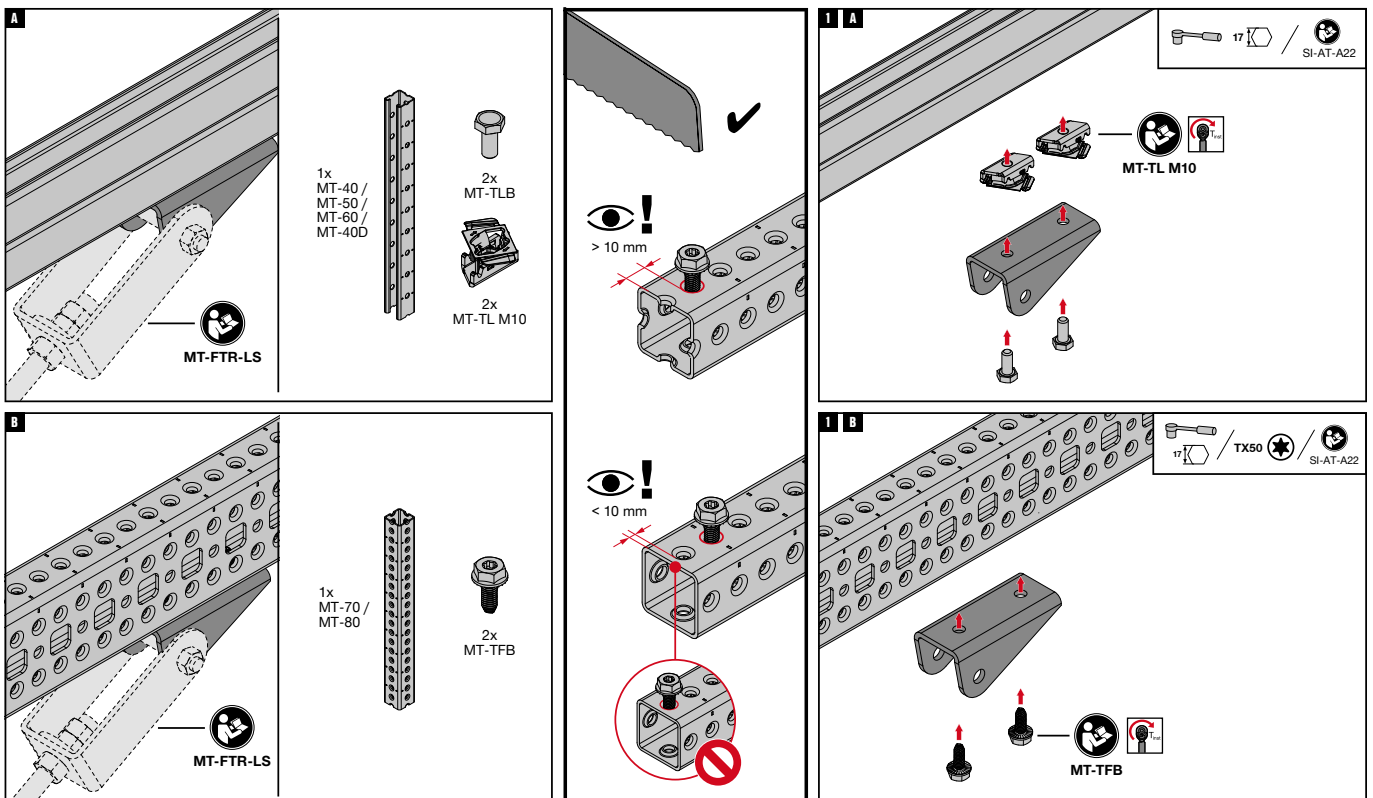

The latest IFU (Instruction for Use) is available on Hilti Online. Please check for any revisions before installing the product.

MT Open C-Channel Connectors

Channel Clamps

4

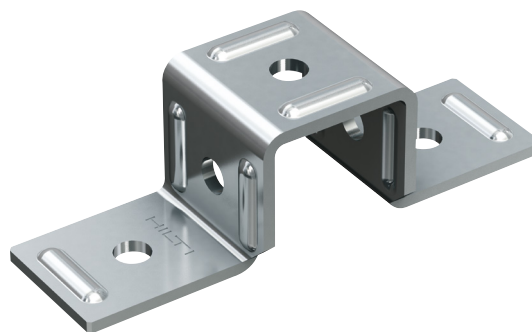
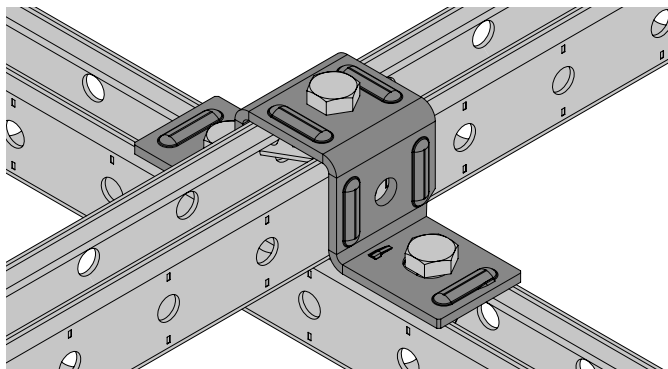

Applications

- Cross-connection of one C-Channel to another Channel or girder
- Suitable for use in dry, indoor environments

Advantages

- Compatible with MT Twist-Lock and MT Thread forming Bolt Channel Connectors – for much faster, adaptable assembly
- Universal – complete many different Applications using few parts

Technical Data

Material composition	Q235 or better steel
Surface finish	Indoor Coated - Electro galvanized

MT-CC-30 Channel Clamp

Order Designation	Technical Data	Sales pack Quantity	Item number	
MT-CC-30	Dry indoor conditions (C1) Indoor with temporary condensation (C2)	10 pc	2322427	

MT-CC-40/50 Channel Clamp

Order Designation	Technical Data	Sales pack Quantity	Item number	
MT-CC-40/50	Dry indoor conditions (C1) Indoor with temporary condensation (C2)	20 pc	2322429	

MT Open C-Channel Connectors

Channel Clamps

MT-CC-40/50X2 Channel Clamp

Order Designation	Technical Data	Sales pack Quantity	Item number	
MT-CC-40/50X2	Dry indoor conditions (C1) Indoor with temporary condensation (C2)	10 pc	2322392	

MT-CC-60 Channel Clamp

Order Designation	Technical Data	Sales pack Quantity	Item number	
MT-CC-60	Dry indoor conditions (C1) Indoor with temporary condensation (C2)	15 pc	2322396	

MT-CC-40D Channel clamp

Order Designation	Technical Data	Sales pack Quantity	Item number	
MT-CC-40D	Dry indoor conditions (C1) Indoor with temporary condensation (C2)	10 pc	2322398	

MT-CC-30D Channel clamp

Order Designation	Technical Data	Sales pack Quantity	Item number	
MT-CC-30D	Dry indoor conditions (C1) Indoor with temporary condensation (C2)	10 pc	2322428	

MT Open C-Channel Connectors

Channel Clamps - Outdoor

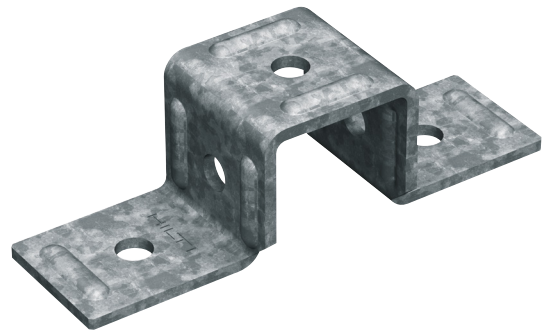
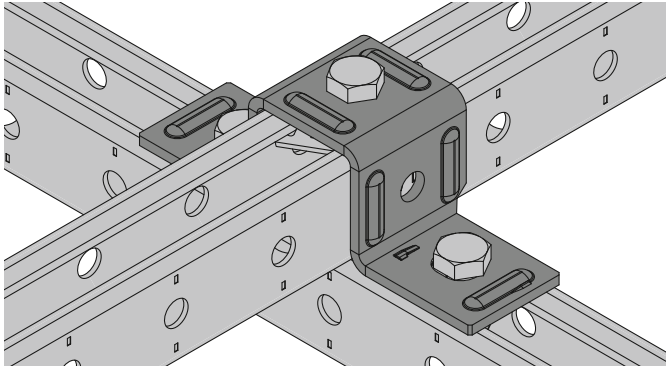

Applications

- Attaching polypanels to a substructure of MT strut/girders
- Hot/cold aisle containment in data centers

Advantages

- Helps lower installation cost – this new solution uses fewer and simpler components than previous Hilti panel Connectors, saving you upfront costs and time on-site
- Compatible with MT Thread forming Bolt Channel Connectors – for much faster, adaptable assembly with higher pull-out and shear resistance
- Corrosion resistance – hot-dip galvanized to help protect against moisture and chemical corrosion

Technical Data

Material composition	Q235 or better steel
Surface finish	Outdoor Coated - HDG

MT-CC-40/50 OC Channel Clamp - Outdoor

Order Designation	Technical Data	Sales pack Quantity	Item number	
MT-CC-40/50 OC	Outdoor, low to moderate pollution (C3 / C4 - low)	20 pc	2322391	

MT-CC-40/50X2 OC Channel Clamp - Outdoor

Order Designation	Technical Data	Sales pack Quantity	Item number	
MT-CC-40/50X2 OC	Outdoor, low to moderate pollution (C3 / C4 - low)	10 pc	2322393	

MT Open C-Channel Connectors

Channel Clamps - Outdoor

4

MT-CC-40D OC Channel Clamp - Outdoor

Order Designation	Technical Data	Sales pack Quantity	Item number	
MT-CC-40D OC	Outdoor, low to moderate pollution (C3)	10 pc	2322399	

MT-CC-60 OC Channel Clamp - Outdoor

Order Designation	Technical Data	Sales pack Quantity	Item number	
MT-CC-60 OC	Outdoor, low to moderate pollution (C3)	15 pc	2322431	

MT Open C-Channel Connectors

Channel Clamps

4

Technical Data MT-Channel Clamps

Item image	Load drawing	Order Designation	+ Fz	- Fz	± Fx	± Fy
		MT-CC-30	-	5,4 kN	2,5 kN	5,7 kN
		MT-CC-40/50 / MT-CC-40/50 OC	-	5,4 kN	2,5 kN	5,7 kN
		MT-CC-40/50x2 / MT-CC-40/50x2 OC	-	2,0 kN	2,5 kN	5,7 kN
		MT-CC-40D / MT-CC-40D OC	-	5,4 kN	2,5 kN	3,6 kN
		MT-CC-60 / MT-CC-60 OC	-	5,4 kN	2,5 kN	3,6 kN
		MT-CC-70 OC	-	5,4 kN	2,5 kN	3,6 kN

Design notes

- Shown load values are recommended values with partial safety factors for actions and resistance included
- Design value = 1,4 * recommended value
- The design resistance of the products is defined in accordance with EN1993

MT Open C-Channel Connectors

Channel Clamps

4

Operation Instruction

MT-CC-40/50 / MT-CC-40/50 OC

2324718-04.2021

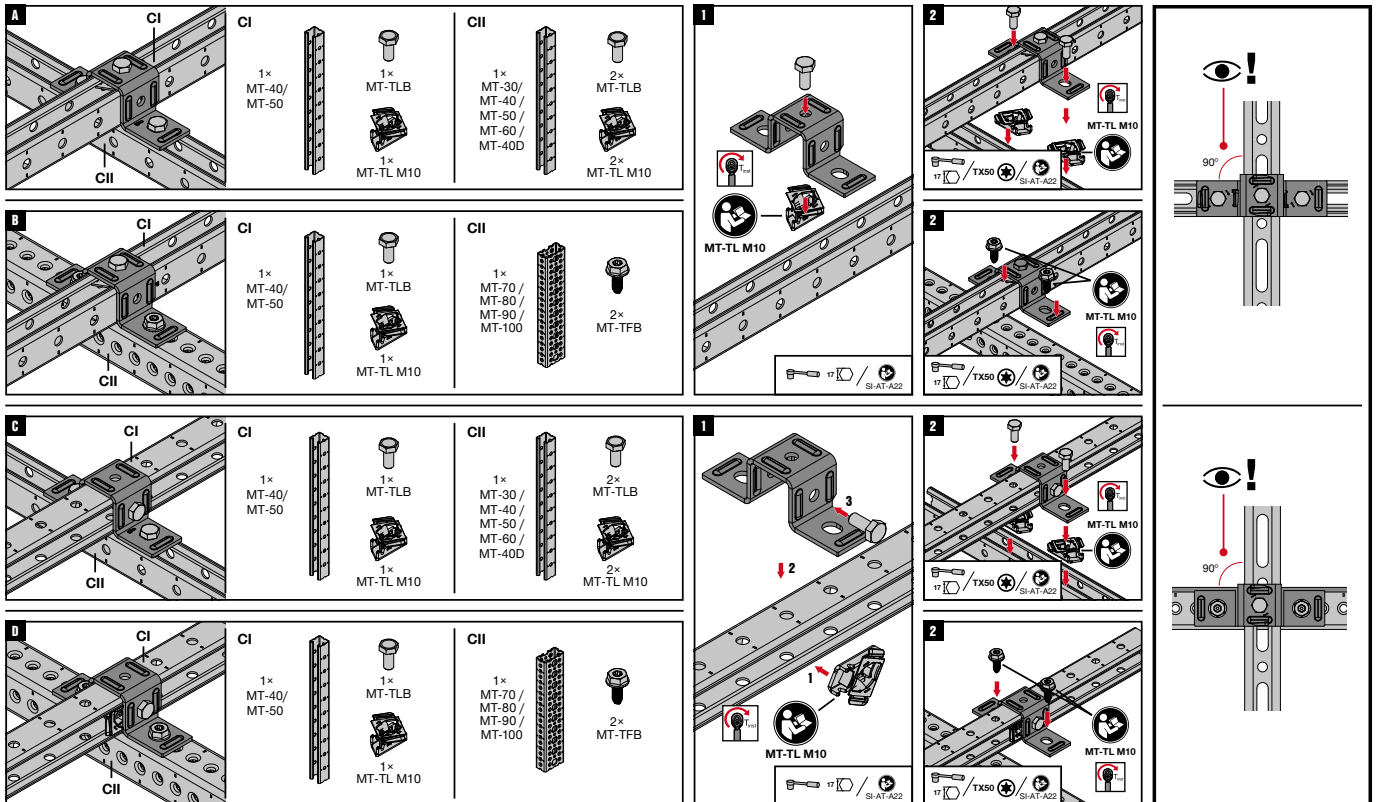

The latest IFU (Instruction for Use) is available on Hilti Online. Please check for any revisions before installing the product.

MT-CC-40/50x2 / MT-CC-40/50x2 OC

2324719-04.2021

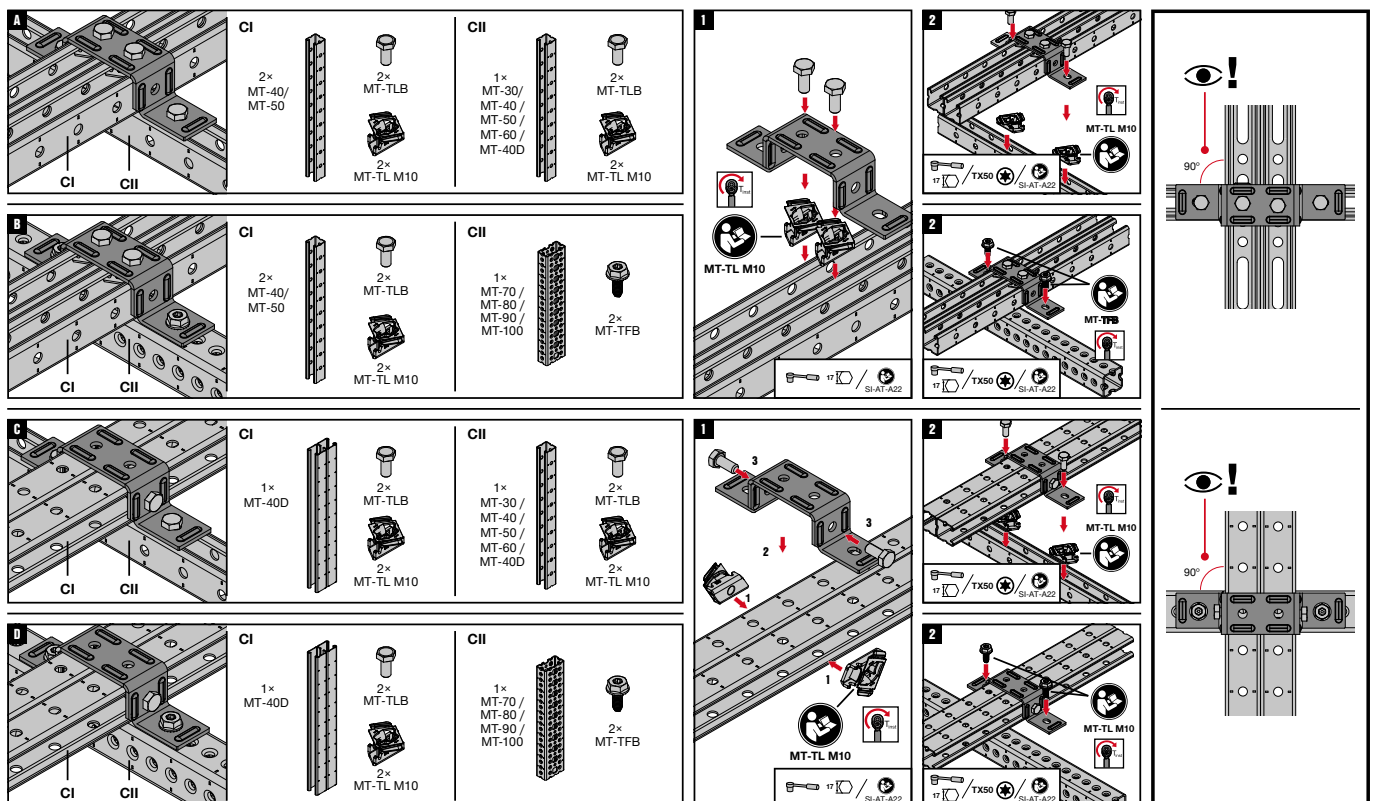

The latest IFU (Instruction for Use) is available on Hilti Online. Please check for any revisions before installing the product.

MT Open C-Channel Connectors

Channel Clamps

Operation Instruction

MT-CC-40D / MT-CC-40D OC

2324717-04.2021

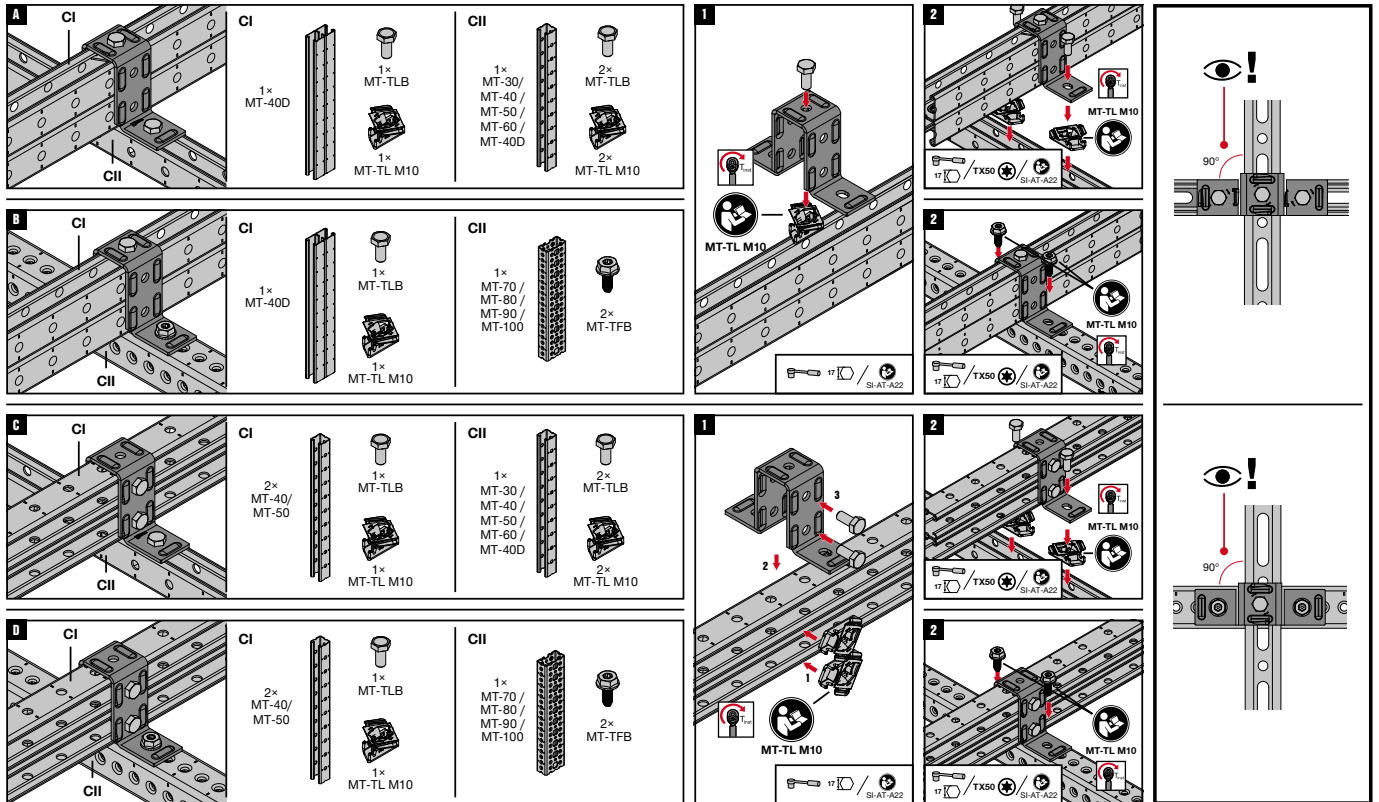

The latest IFU (Instruction for Use) is available on Hilti Online. Please check for any revisions before installing the product.

MT-CC-30 / MT-CC-40/50 / MT-CC-60 / MT-CC-30 OC / MT-CC-40/50 OC / MT-CC-60 OC

232516-04.2021

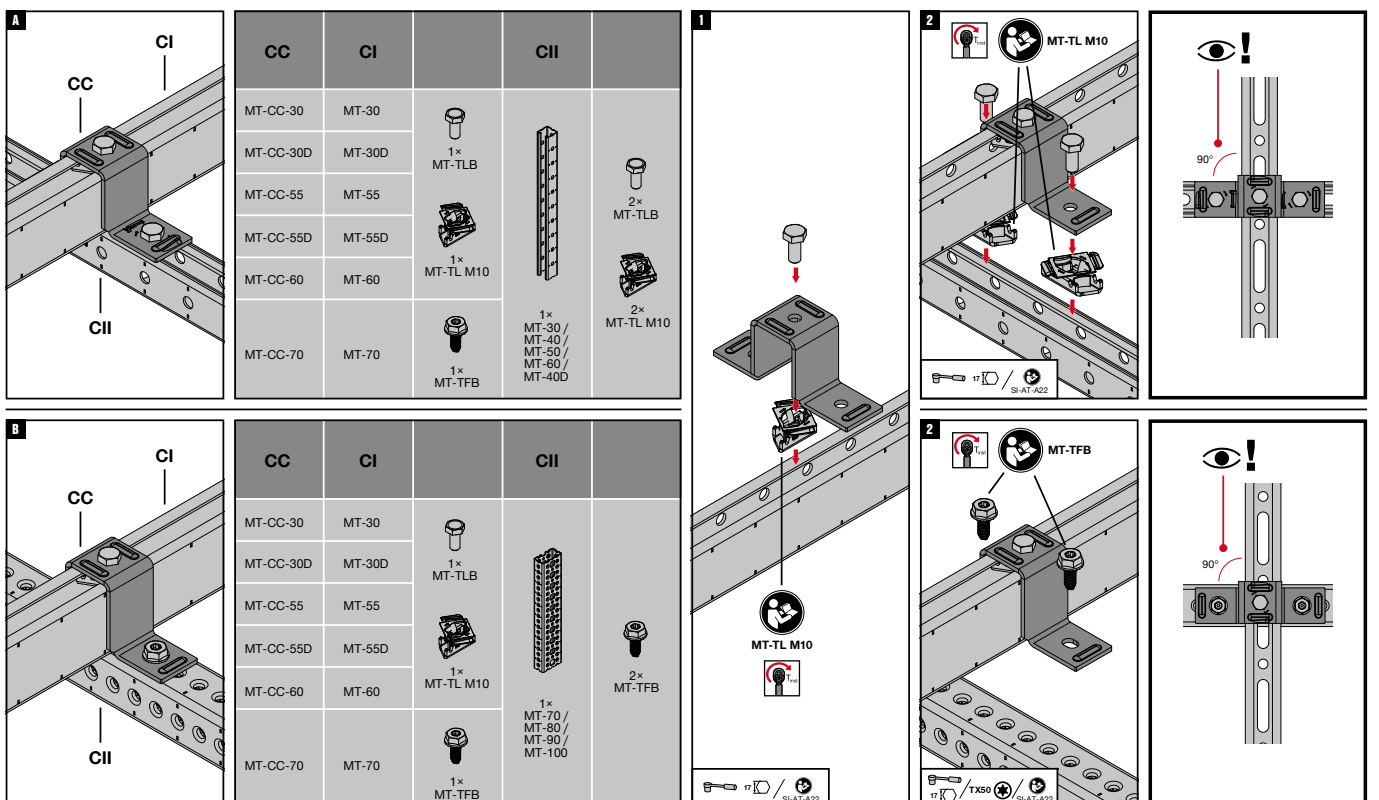

The latest IFU (Instruction for Use) is available on Hilti Online. Please check for any revisions before installing the product.

MT Open C-Channel Fast-Lock Connectors

Pre-assembled Fast-Lock nut and bolt for assembling light-duty C-Channel structures



Applications

- Right-angle connections between any MT C-Channels
- Assembling 2D metal framing for MEP support structures with light loads
- Suitable for use in dry, indoor environments

Technical Data

Material composition	DD11 MOD
Surface finish	Indoor-coated Electro-galvanized

Advantages

- Faster installations – pre-assembled with the Hilti MT Fast-Lock, our fastest method for assembling a modular support system with fewer steps
- Simplified stock management – pre-assembly greatly reduces the total number of MT components, for easier purchasing, handling, and storage
- Consistent installation quality – pre-assembly removes additional steps, helping reduce assembly errors for safer installations
- Part of the Hilti MT system – an economical, all-in-one solution for virtually all modular MEP support structures
- Extensive software support - PROFIS Modular Support Engineering, BIMCAD content, and Revit® families are all available to streamline design and ordering

MT-C-LL1 FL Pre-assembled Channel Connector

Order Designation	Material composition	Technical Data	Sales pack quantity	Item number	
MT-C-LL1 FL	Q235B	Dry indoor conditions (C1) Indoor with temporary condensation (C2)	16 pc	2399637	

MT-C-Q1 FL Pre-assembled Channel Connector

Order Designation	Material composition	Technical Data	Sales pack quantity	Item number	
MT-C-Q1 FL	DD11 MOD	Dry indoor conditions (C1) Indoor with temporary condensation (C2)	16 pc	2399638	

MT Open C-Channel Fast-Lock Connectors

4

MT-C-LL2 FL Pre-assembled Channel Connector

Order Designation	Material composition	Technical Data	Sales pack quantity	Item number	
MT-C-LL2 FL	S235JR, Q235B	Dry indoor conditions (C1) Indoor with temporary condensation (C2)	16 pc	2399661	

MT-C-L2E FL Pre-assembled Channel Connector

Order Designation	Material composition	Technical Data	Sales pack quantity	Item number	
MT-C-L2E FL	S235JR	Dry indoor conditions (C1) Indoor with temporary condensation (C2)	12 pc	2399666	

MT-CC-40/50 FL Pre-assembled Channel Clamp

Order Designation	Material composition	Technical Data	Sales pack quantity	Item number	
MT-CC-40/50 FL	Q235B	Dry indoor conditions (C1) Indoor with temporary condensation (C2)	12 pc	2399667	

MT-C-T/2 FL Pre-assembled Channel Connector

Order Designation	Material composition	Technical Data	Sales pack quantity	Item number	
MT-C-T/2 FL	S235JR, Q235B	Dry indoor conditions (C1) Indoor with temporary condensation (C2)	12 pc	2399668	

MT-ES-40 FL Pre-assembled Channel Connector

Order Designation	Material composition	Technical Data	Sales pack quantity	Item number	
MT-ES-40 FL	S235JR, Q235B	Dry indoor conditions (C1) Indoor with temporary condensation (C2)	14 pc	2399669	

MT Fast-Lock seismic hinges

One-hole hinged Connector with pre-assembled Fast-Lock nut and bolt for assembling Seismic Bracing of MT C-Channel framing

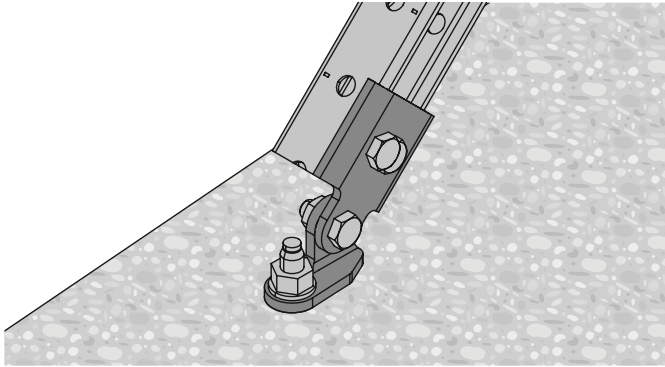

Applications

- Seismic bracing of C-Channel framing
- Anchoring C-Channel brace members to concrete for use as Seismic Bracing
- Connecting C-Channel brace members to MT-S-L seismic angle Brackets for use as Seismic Bracing
- Suitable for use in dry, indoor environments

Technical Data

Material composition	DD11 MOD
Surface finish	Indoor-coated Electro-galvanized

Advantages

- Faster installations – pre-assembled with the Hilti MT Fast-Lock, our fastest method for assembling a modular support system with fewer steps
- Simplified stock management – pre-assembly greatly reduces the total number of MT components, for easier purchasing, handling, and storage
- Consistent installation quality – pre-assembly removes additional steps, helping reduce assembly errors for safer installations
- Easy to install – pivoting joint simplifies assembly and fastening
- Part of the Hilti MT system – an economical, all-in-one solution for virtually all modular MEP support structures
- Extensive software support - PROFIS Modular Support Engineering, BIMCAD content, and Revit® families are all available to streamline design and ordering

MT-S-H1 FL Pre-assembled Seismic Hinge

Order Designation	Material composition	Technical Data	Anchorage - D	Sales pack quantity	Item number	
MT-S-H1 FL M10	Q235B	Dry indoor conditions (C1) Indoor with temporary condensation (C2)	11,55 mm	14 pc	2399662	
MT-S-H1 FL M12	Q235B	Dry indoor conditions (C1) Indoor with temporary condensation (C2)	13,65 mm	14 pc	2399663	

MT-S-L FL 40 seismic angle Bracket

Angle Bracket with pre-assembled Fast-Lock nut and bolt for assembling braced MT-40 C-Channel structures in seismic zones

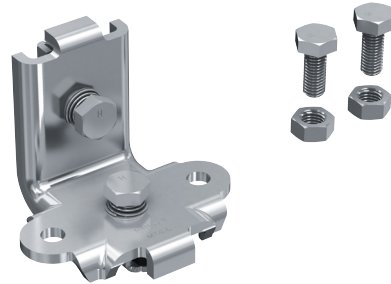
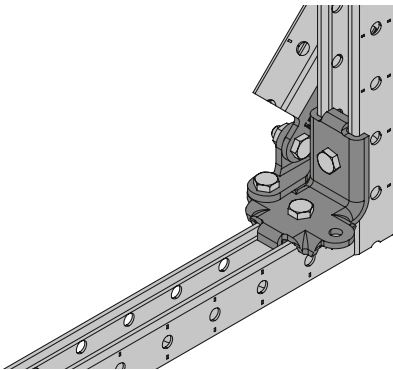

Applications

- Right-angle connections between MT-40 C-Channels with connection to Seismic Bracing
- Assembling metal framing for MEP support structures in seismic zones
- Suitable for use in dry, indoor environments

Advantages

- Faster installations – pre-assembled with the Hilti MT Fast-Lock, our fastest method for assembling a modular support system with fewer steps
- Simplified stock management – pre-assembly greatly reduces the total number of MT components, for easier purchasing, handling, and storage
- Consistent installation quality – pre-assembly removes additional steps, helping reduce assembly errors for safer installations
- Winged angle Connector – includes connection points to MT-S-H1
- Part of the Hilti MT system – an economical, all-in-one solution for virtually all modular MEP support structures
- Extensive software support - PROFIS Modular Support Engineering, BIMCAD content, and Revit® families are all available to streamline design and ordering

Technical Data

Material composition	DD11 MOD
Surface finish	Indoor-coated Electro-galvanized

MT-S-L FL Pre-assembled Seismic Angle Bracket

Order Designation	Material composition	Technical Data	Sales pack quantity	Item number	
MT-S-L FL seismic	S235JR, Q235B	Dry indoor conditions (C1) Indoor with temporary condensation (C2)	14 pc	2399664	

MT Open C-Channel Fast-Lock Connectors - Outdoor

Right-angle Connector with pre-assembled Fast-Lock nut and bolt for assembling C-Channel structures, for outdoor use with low pollution

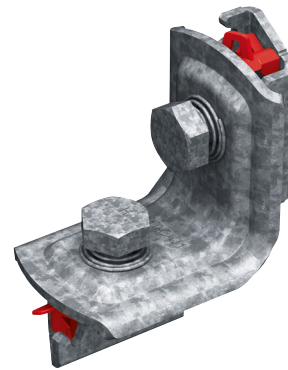

Applications

- Fastening L-shaped connections between any MT C-Channels
- Assembling 2D metal framing for MEP support structures, such as C-Trapeze
- Suitable for use in moderately corrosive environments

Technical Data

Material composition	Q235B
Surface finish	Hot Dip Galvanized

Advantages

- Faster installations – pre-assembled with the Hilti MT Fast-Lock, our fastest method for assembling a modular support system with fewer steps
- Simplified stock management – pre-assembly greatly reduces the total number of MT components, for easier purchasing, handling, and storage
- Consistent installation quality – pre-assembly removes additional steps, helping reduce assembly errors for safer installations
- Part of the Hilti MT system – an economical, all-in-one solution for virtually all modular MEP support structures
- Corrosion resistance – hot-dip galvanized to help protect against moisture and chemical corrosion

MT-C-LL1 FL OC Pre-assembled Channel Connector - Outdoor

Order Designation	Material composition	Technical Data	Sales pack quantity	Item number	
MT-C-LL1 FL OC	Q235B	Outdoor, low to moderate pollution (C3 / C4 - low)	16 pc	2399672	

MT-C-Q1 FL OC Pre-assembled Channel Connector - Outdoor

Order Designation	Material composition	Technical Data	Sales pack quantity	Item number	
MT-C-Q1 FL OC	DD11 MOD	Outdoor, low to moderate pollution (C3 / C4 - low)	16 pc	2399673	

MT Open C-Channel Fast-Lock Connectors - Outdoors

4

MT-C-LL2 FL OC Pre-assembled Channel Connector - Outdoors

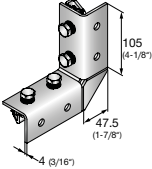
Order Designation	Material composition	Technical Data	Sales pack quantity	Item number	
MT-C-LL2 FL OC	S235JR, Q235B	Outdoor, low to moderate pollution (C3 / C4 - low)	16 pc	2399676	

MT-C-L2E FL OC Pre-assembled Channel Connector- Outdoors

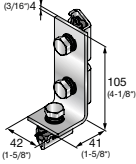
Order Designation	Material composition	Technical Data	Sales pack quantity	Item number	
MT-C-L2E FL OC	S235JR	Outdoor, low to moderate pollution (C3 / C4 - low)	12 pc	2399678	

MT-CC-40/50 FL OC Pre-assembled Channel Clamp- Outdoors

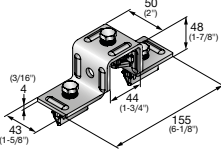
Order Designation	Material composition	Technical Data	Sales pack quantity	Item number	
MT-CC-40/50 FL OC	Q235B	Outdoor, low to moderate pollution (C3 / C4 - low)	12 pc	2399679	

MT-C-T/2 FL OC Pre-assembled Channel Connector - Outdoors

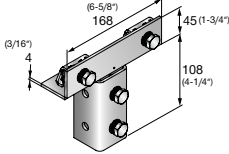
Order Designation	Material composition	Technical Data	Sales pack quantity	Item number	
MT-C-T/2 FL OC	S235JR, Q235B	Outdoor, low to moderate pollution (C3 / C4 - low)	12 pc	2399680	

MT-ES-40 FL OC Pre-assembled Channel Connector - Outdoors

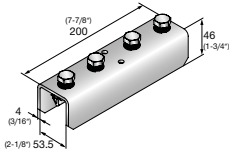
Order Designation	Material composition	Technical Data	Sales pack quantity	Item number	
MT-ES-40 FL OC	S235JR, Q235B	Outdoor, low to moderate pollution (C3 / C4 - low)	14 pc	2399681	

Technical Data Fast-Lock Components

Item image	Load drawing	Order Designation	+ Fx	- Fx	+ Fy	- Fy	+ Fz	- Fz
		MT-C-LL1 FL/ MT-C-LL1 FL OC	5,76 kN	5,86 kN	0,89 kN	0,89 kN	5,86 kN	5,76 kN
		MT-C-Q1 FL/ MT-C-Q1 FL OC	5,60 kN	4,35 kN	0,40 kN	0,40 kN	5,60 kN	4,35 kN
		MT-C-LL2 FL / MT-C-LL2 FL OC	5,21 kN	8,81 kN	3,57 kN	0,89 kN	8,81 kN	5,21 kN
		MT-S-H1 FL M10	5,00 kN	5,00 kN	-	-	-	-
		MT-S-H1 FL M12	5,00 kN	5,00 kN	-	-	-	-

Design notes

- Shown load values are recommended values with partial safety factors for actions and resistance included
- Design value = 1.4 * recommended value
- The design resistance of the products is defined in accordance with EN1993

Technical Data Fast-Lock Connector

Item image	Load drawing	Order Designation	+ Fx	- Fx	+ Fy	- Fy	+ Fz	- Fz
		MT-S-L-40 FL	2,64 kN	3,43 kN	1,86 kN	1,86 kN	6,14 kN	5,93 kN
		MT-B-L FL / MT-B-L FL OC	2,14 kN	5,00 kN	--	--	5,00 kN	2,14 kN
		MT-C-L2E FL / MT-C-L2E FL OC	4,35 kN	7,20 kN	2,50 kN	2,50 kN	9,50 kN	5,70 kN
		MT-CC-40/50 FL / MT-CC-40/50 FL OC	2,50 kN	2,50 kN	5,71 kN	5,71 kN	--	5,36 kN
		MT-C-T/2 FL / MT-C-T/2 FL OC	5,00 kN	6,38 kN	0,66 kN	0,66 kN	7,01 kN	7,01 kN
		MT-ES-40 FL / MT-ES-40 FL OC	10,00 kN	10,00 kN	0,56 kN	0,56 kN	10,00 kN	10,00 kN

Design notes

- Shown load values are recommended values with partial safety factors for actions and resistance included
- Design value = 1.4 * recommended value
- The design resistance of the products is defined in accordance with EN1993

MT Fast-Lock Components

4

Operation Instruction MT-S-L FL

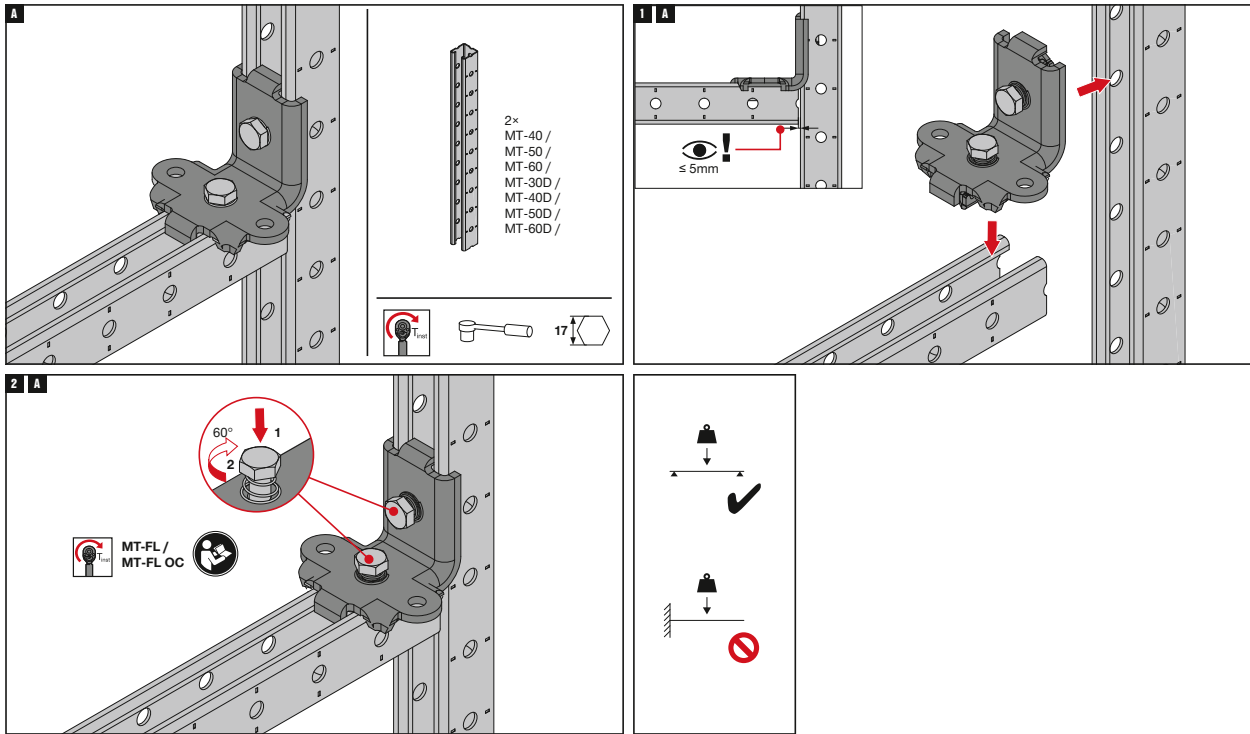

The latest IFU (Instruction for Use) is available on Hilti Online. Please check for any revisions before installing the product.

Operation Instruction MT-ES-40 FL / MT-ES-40 FL OC

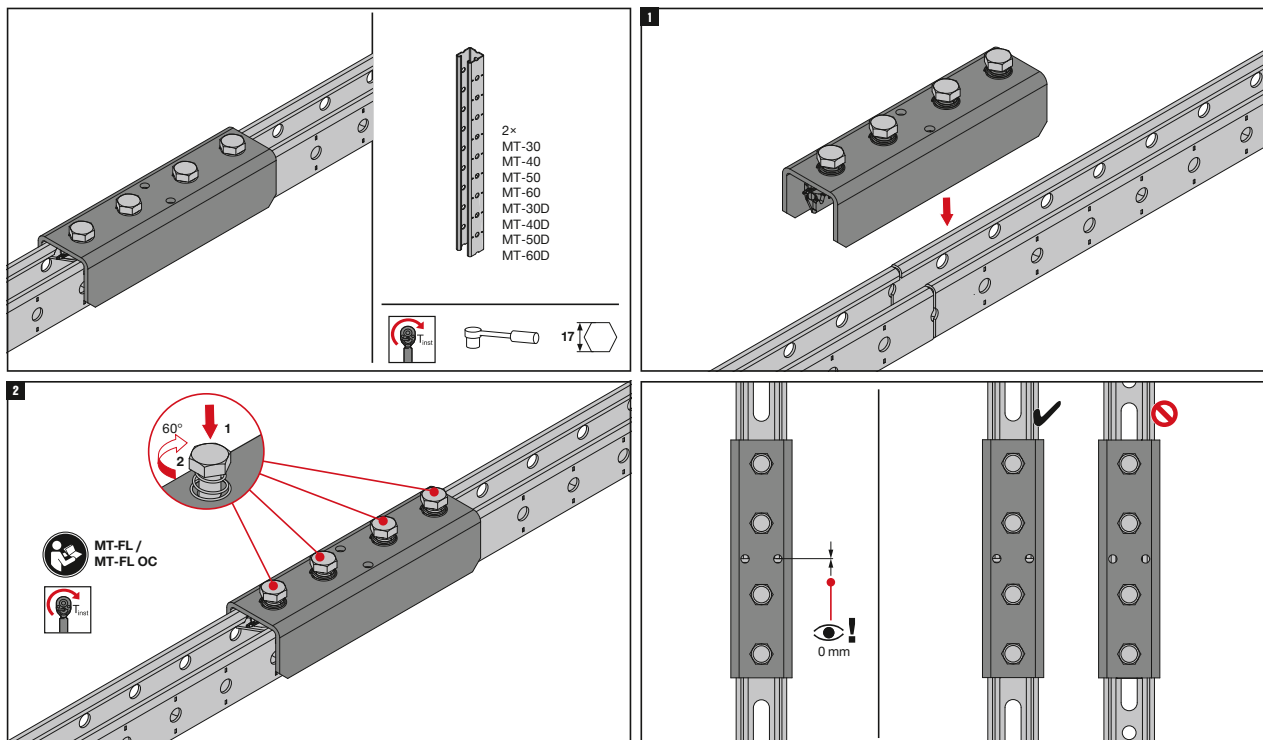

The latest IFU (Instruction for Use) is available on Hilti Online. Please check for any revisions before installing the product.

Operation Instruction
MT-S-H1 FL M10 / M12

4

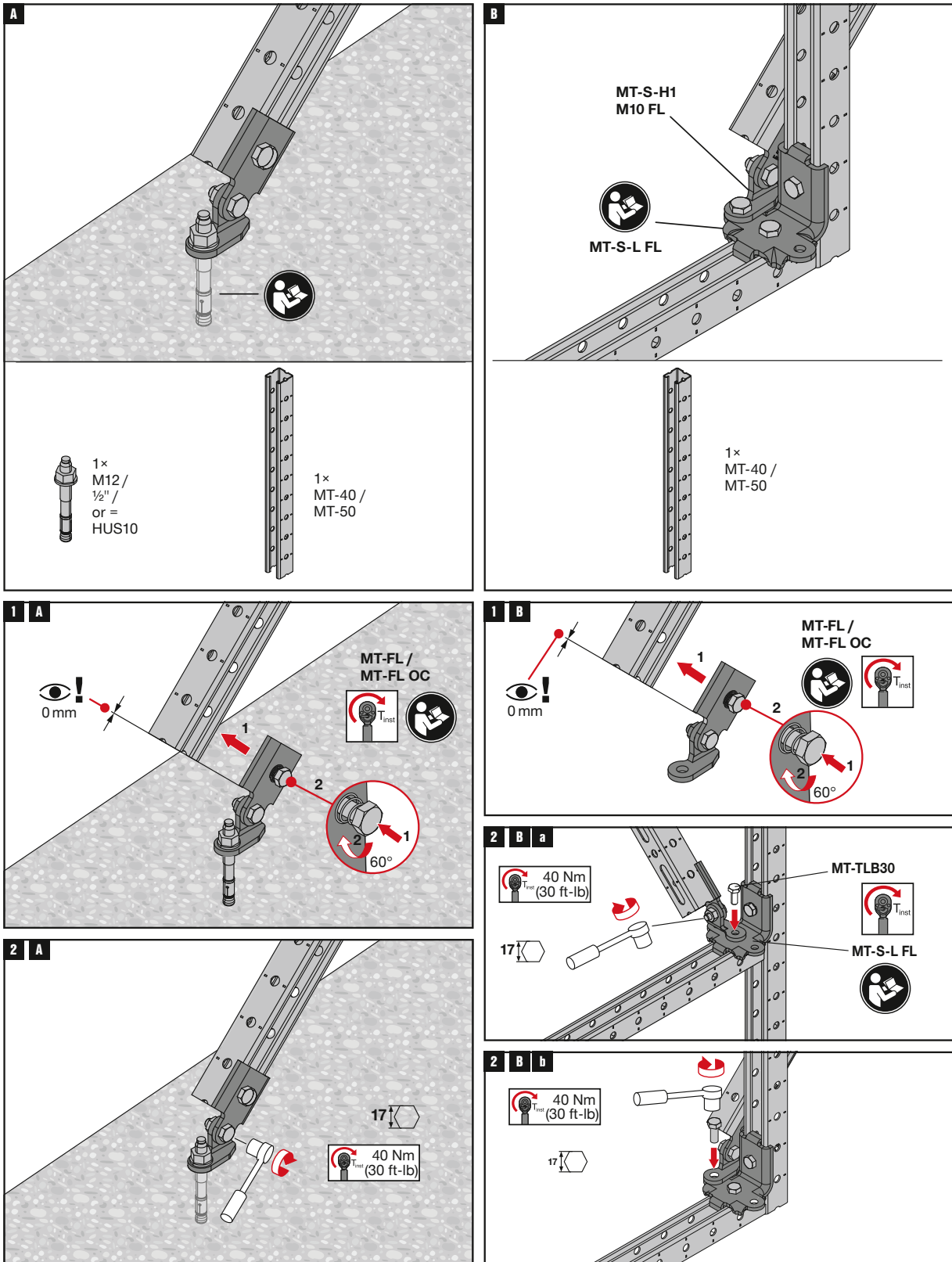

The latest IFU (Instruction for Use) is available on Hilti Online. Please check for any revisions before installing the product.

MT Fast-Lock Components

4

Operation Instruction

MT-C-T/2 FL / MT-C-T/2 FL OC

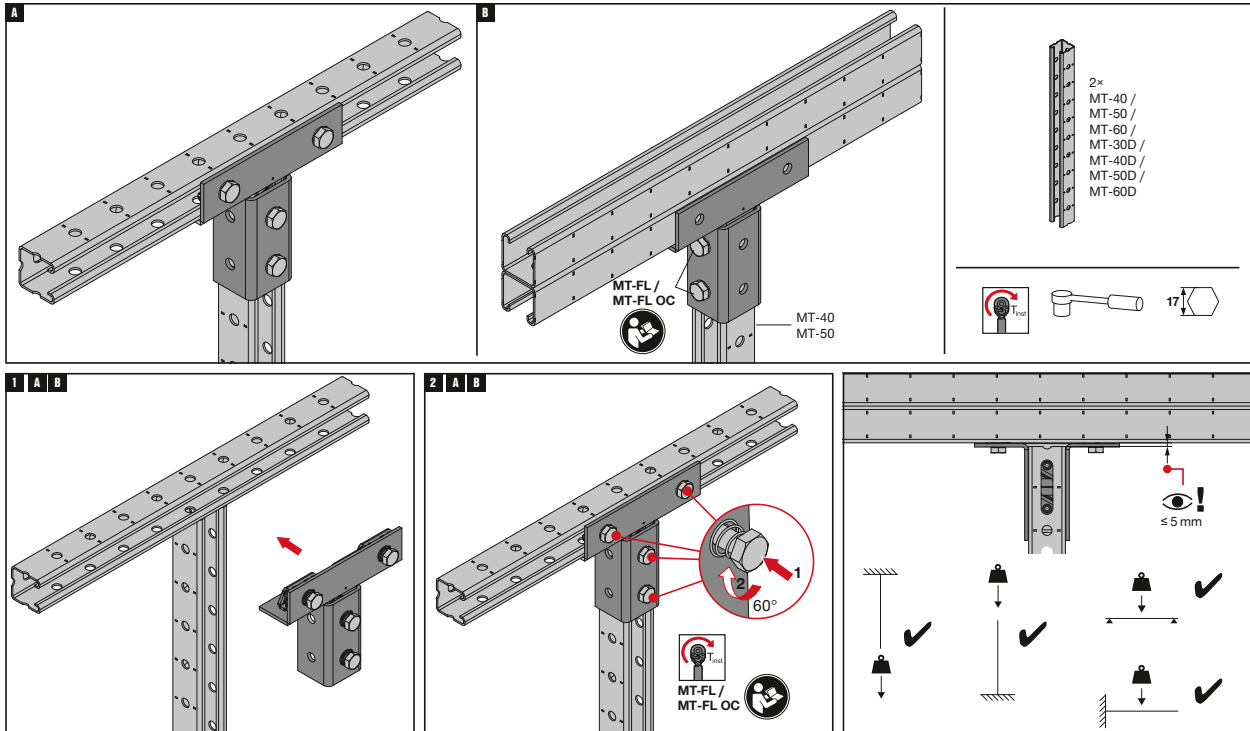

The latest IFU (Instruction for Use) is available on Hilti Online. Please check for any revisions before installing the product.

Operation Instruction

MT-C-Q1 FL / MT-C-Q1 FL OC

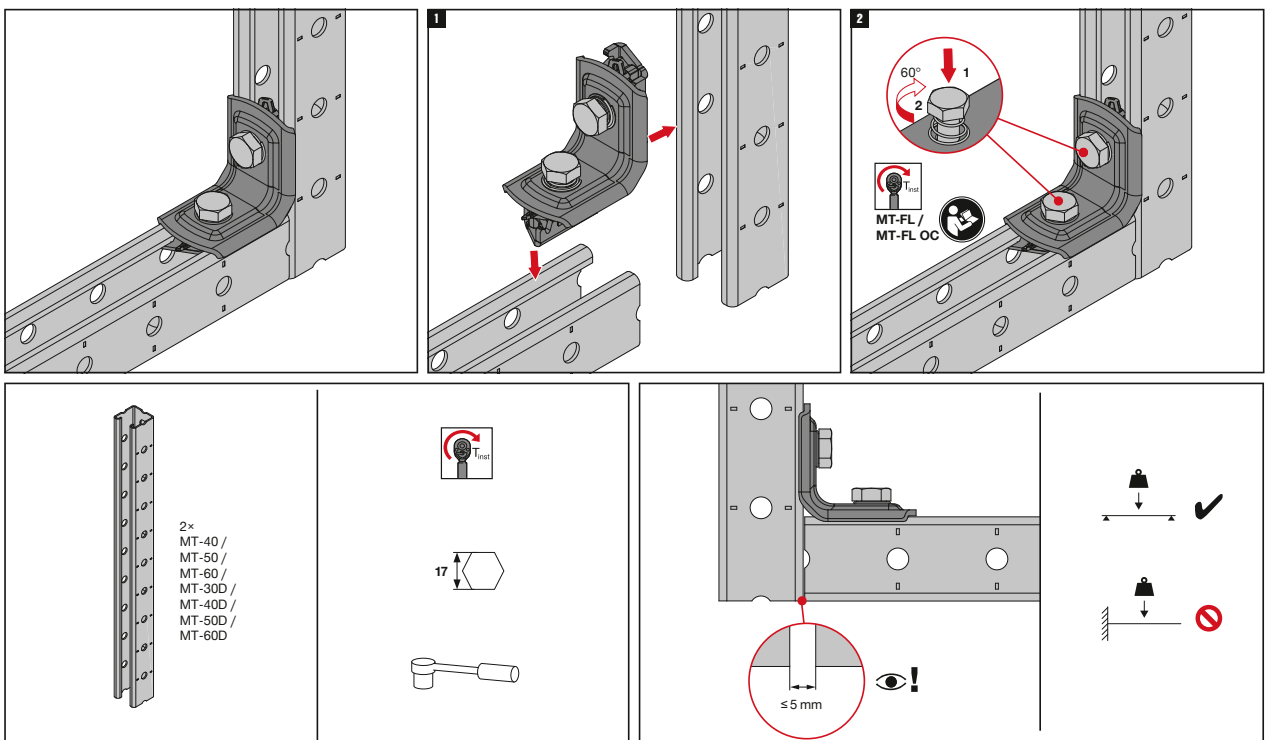

The latest IFU (Instruction for Use) is available on Hilti Online. Please check for any revisions before installing the product.

MT Fast-Lock Components

4 Operation Instruction MT-C-LL1 FL / MT-C-LL1 FL OC

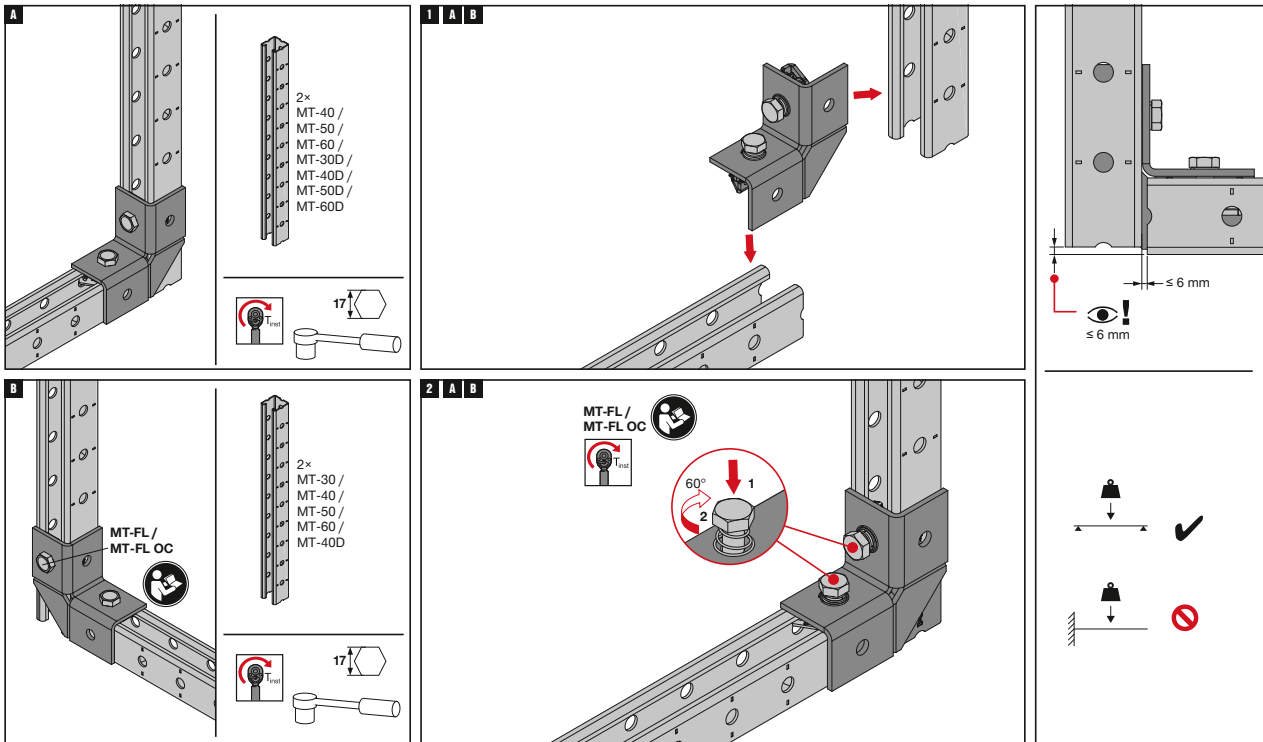

The latest IFU (Instruction for Use) is available on Hilti Online. Please check for any revisions before installing the product.

MT-C-LL2 FL / MT-C-LL2 FL OC

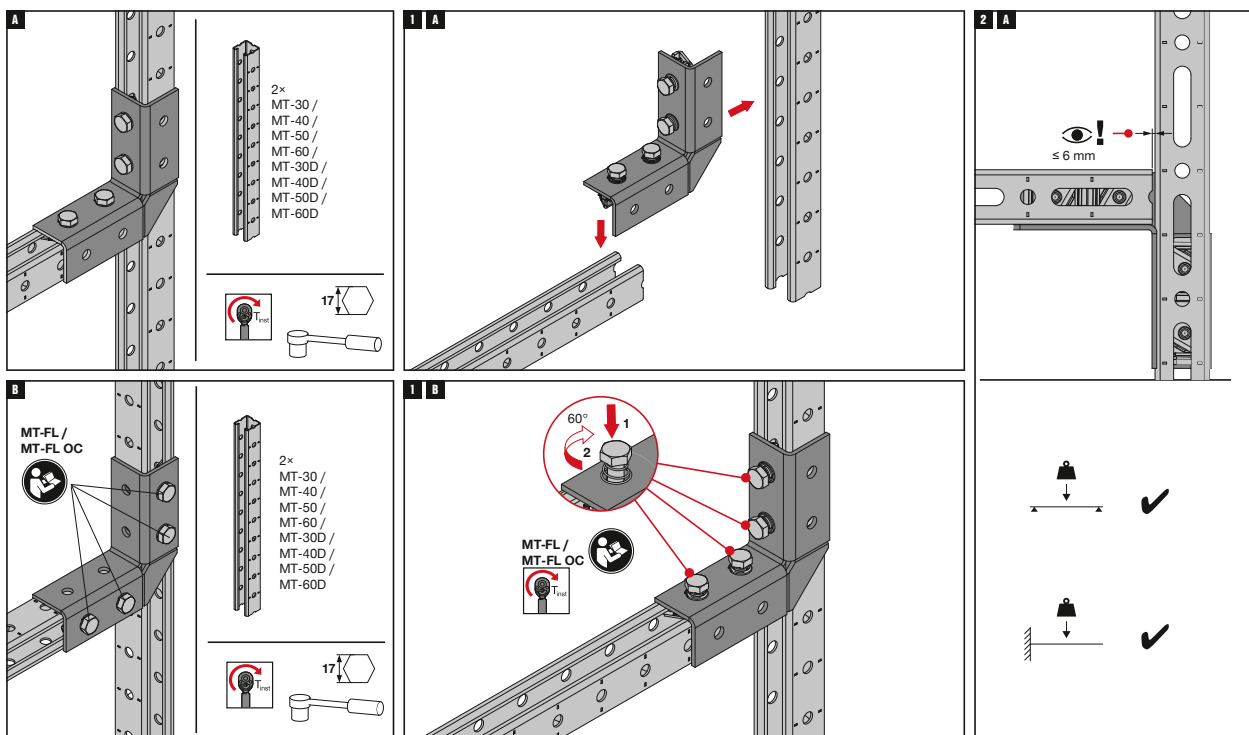

The latest IFU (Instruction for Use) is available on Hilti Online. Please check for any revisions before installing the product.

MT Fast-Lock Components

Operation Instruction

MT-C-L2E FL / MT-C-L2E FL OC

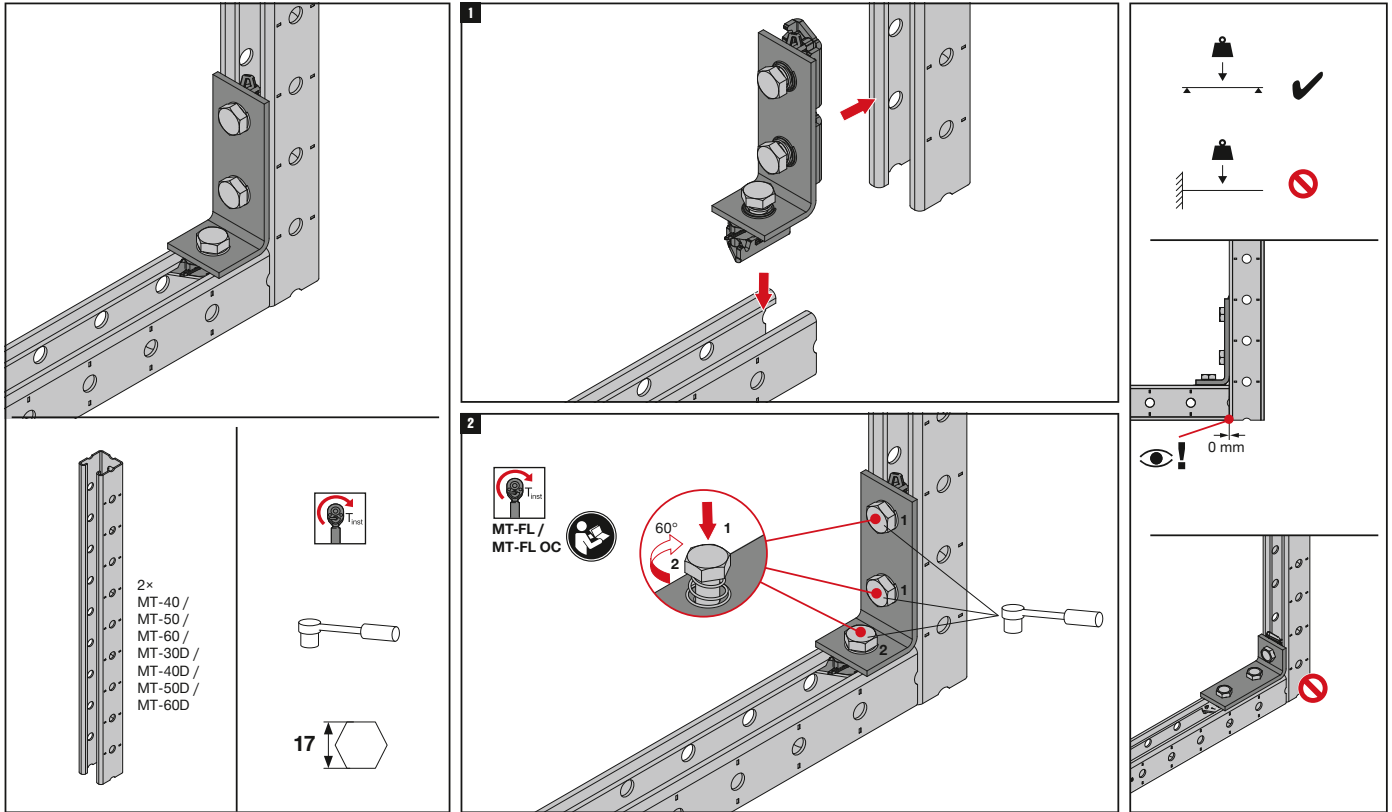

The latest IFU (Instruction for Use) is available on Hilti Online. Please check for any revisions before installing the product.

Operation Instruction

MT-CC-40/50 FL / MT-CC-40/50 FL OC

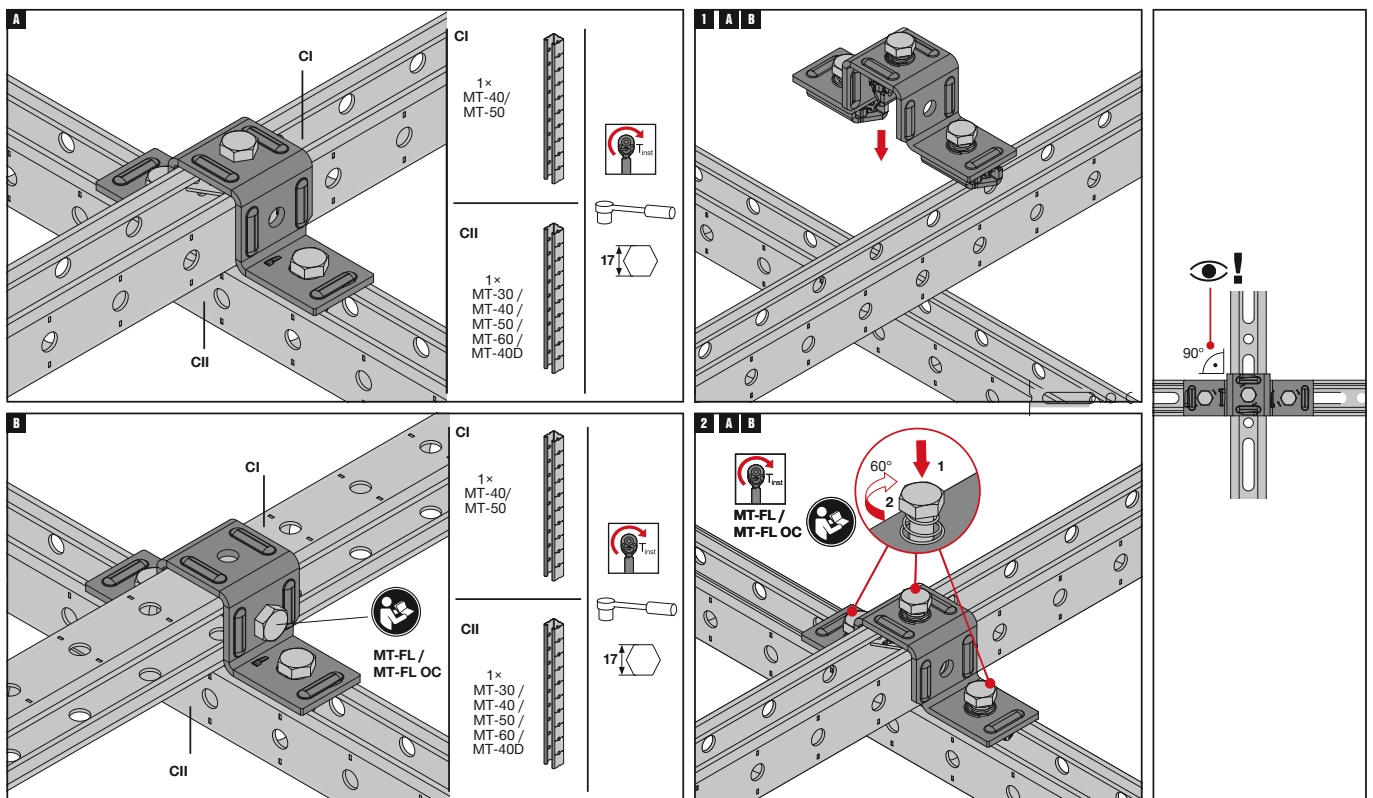

The latest IFU (Instruction for Use) is available on Hilti Online. Please check for any revisions before installing the product.

MT Fast-Lock Components

Operation Instruction MT-B-T FL / MT-B-T FL OC

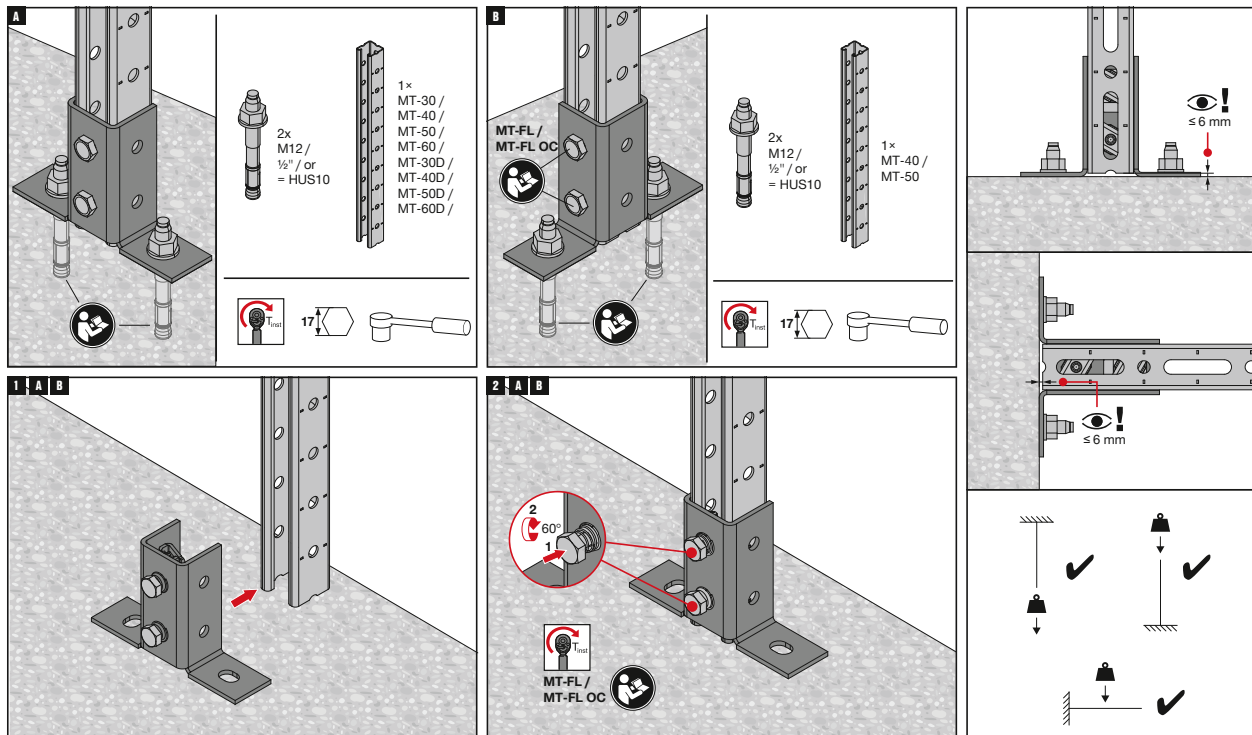

The latest IFU (Instruction for Use) is available on Hilti Online. Please check for any revisions before installing the product.

Operation Instruction MT-B-O2 FL / MT-B-O2 FL OC

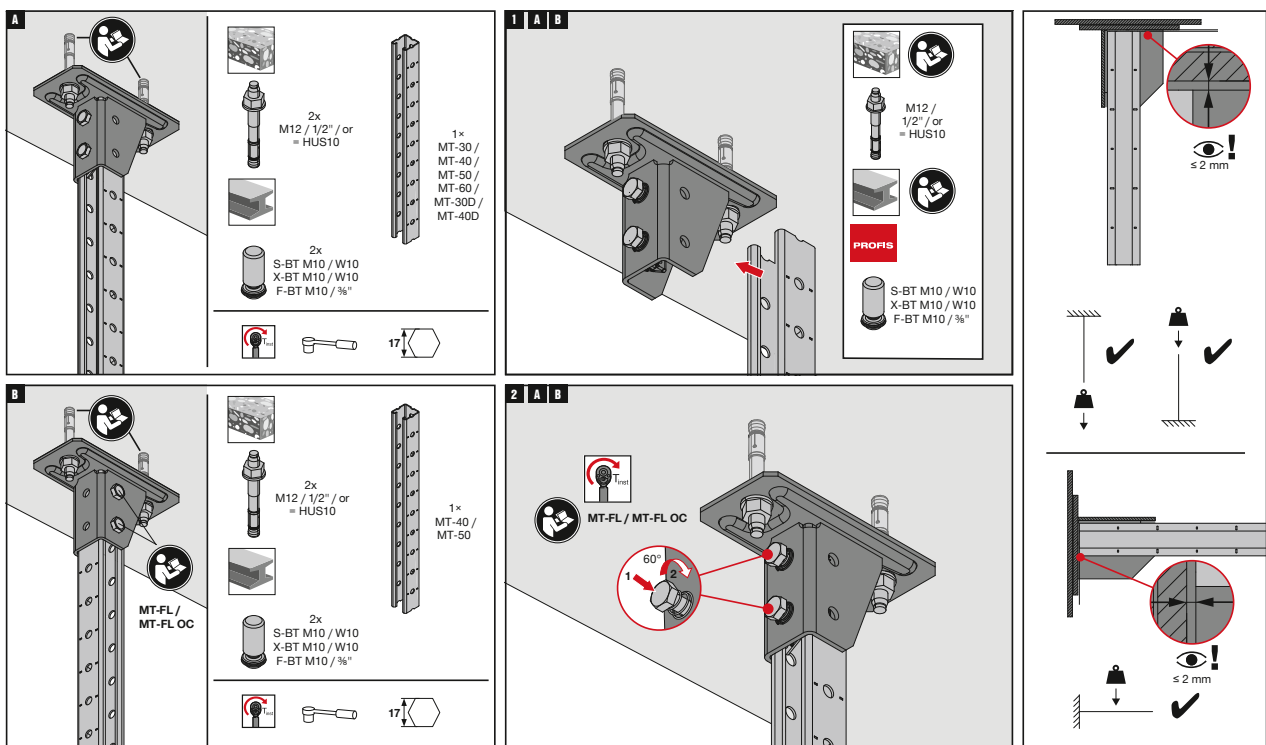

The latest IFU (Instruction for Use) is available on Hilti Online. Please check for any revisions before installing the product.

MT Box Profiles Connectors

90° Connectors - Outdoor

4

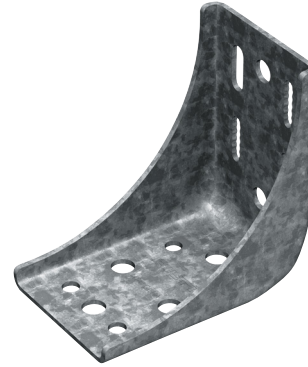

Applications

- Right-angle connections between any MT Box Profiles or Profile Channels
- Assembling metal framing for MEP support structures when resistance to 3D stresses is required
- Fastening MT C-Channel to concrete floors, walls or ceilings

Technical Data

Material composition	Q355 or better steel
Surface finish	Hot-dip galvanized - for outdoor use

Advantages

- Faster to install - with MT T-head bolts (MT-THB OC) or MT thread forming bolts (MT-TFB OC). Compatible with Hilti Adaptive Torque system, to help avoid over- or undertorquing of critical connecting elements (compatible tool and SI-AT module required)
- Versatile and secure connections - use vertical oblong holes to adjust height in 5mm (1/4") increments and cloud holes with thread forming bolts (MT-TFB) for secure connections between MT Box Profiles
- Seamless adjustability - use the anchor holes in the middle of the angle Connector for mounting to MT-90H Profiles, allowing you to attach, adjust and re-adjust at any point along the Profile's seamless groove
- Flexible - angle Connectors can also be used as a base-plate, anchored to concrete, or directly fastened to steel. Combine one, two or four of them, for the best fit to your load requirements

MT-C-GS OC Angle Connector - Outdoor

Order Designation	Technical Data	Sales pack Quantity	Item number	
MT-C-GS OC	Outdoor, low to moderate pollution (C3 / C4 - low)	10 pc	2272064	

MT-C-GS A OC Angle Connector - Outdoor

Order Designation	Technical Data	Sales pack Quantity	Item number	
MT-C-GS A OC	Outdoor, low to moderate pollution (C3 / C4 - low)	10 pc	2272068	

MT Box Profiles Connectors

90° Connectors - Outdoor

4

MT-C-GS HA OC Angle Connector - Outdoor

Order Designation	Technical Data	Sales pack Quantity	Item number	
MT-C-GS HA OC	Outdoor, low to moderate pollution (C3 / C4 - low)	10 pc	2430775	

MT-C-GL OC Angle Connector - Outdoor

Order Designation	Technical Data	Sales pack Quantity	Item number	
MT-C-GL OC	Outdoor, low to moderate pollution (C3 / C4 - low)	10 pc	2272066	

MT-C-GL A OC Angle Connector - Outdoor

Order Designation	Technical Data	Sales pack Quantity	Item number	
MT-C-GL A OC	Outdoor, low to moderate pollution (C3 / C4 - low)	10 pc	2272069	

MT-C-GL HA OC Angle Connector - Outdoor

Order Designation	Technical Data	Sales pack Quantity	Item number	
MT-C-GL HA OC	Outdoor, low to moderate pollution (C3 / C4 - low)	10 pc	2430759	

MT Box Profiles Connectors

90° Connectors - Outdoor

4

Technical Data MT Angle Connectors - Outdoor

Item image	Load drawing	Order Designation	+ Fz	- Fz	± Fx	± Fy
		MT-C-GS OC	11,9 kN	7,6 kN	5,2 kN	2,6 kN
		MT-C-GS A OC	11,9 kN	7,6 kN	5,2 kN	2,6 kN
		MT-C-GS HA OC	11,9 kN	7,6 kN	5,2 kN	2,6 kN

Design notes

- Shown load values are recommended values with partial safety factors for actions and resistance included
- Design value = 1.4 * recommended value
- The design resistance of the products is defined in accordance with EN1993

Technical Data MT Angle Connectors - Outdoor

Item image	Load drawing	Order Designation	+ Fz	- Fz	± Fx	± Fy
		MT-C-GL OC	14,6 kN	13,5 kN	16,5 kN	11,7 kN
		MT-C-GL A OC	14,6 kN	13,5 kN	16,5 kN	11,7 kN
		MT-C-GL HA OC	13,7 kN	4,9 kN	2,0 kN	3,0 kN

Design notes

- Shown load values are recommended values with partial safety factors for actions and resistance included
- Design value = 1.5 * recommended value
- The design resistance of the products is defined in accordance with EN1993

MT Box Profiles Connectors

90° Connectors - Outdoor

4

Operation Instruction

MT-C-GS OC

2290665-06.2020

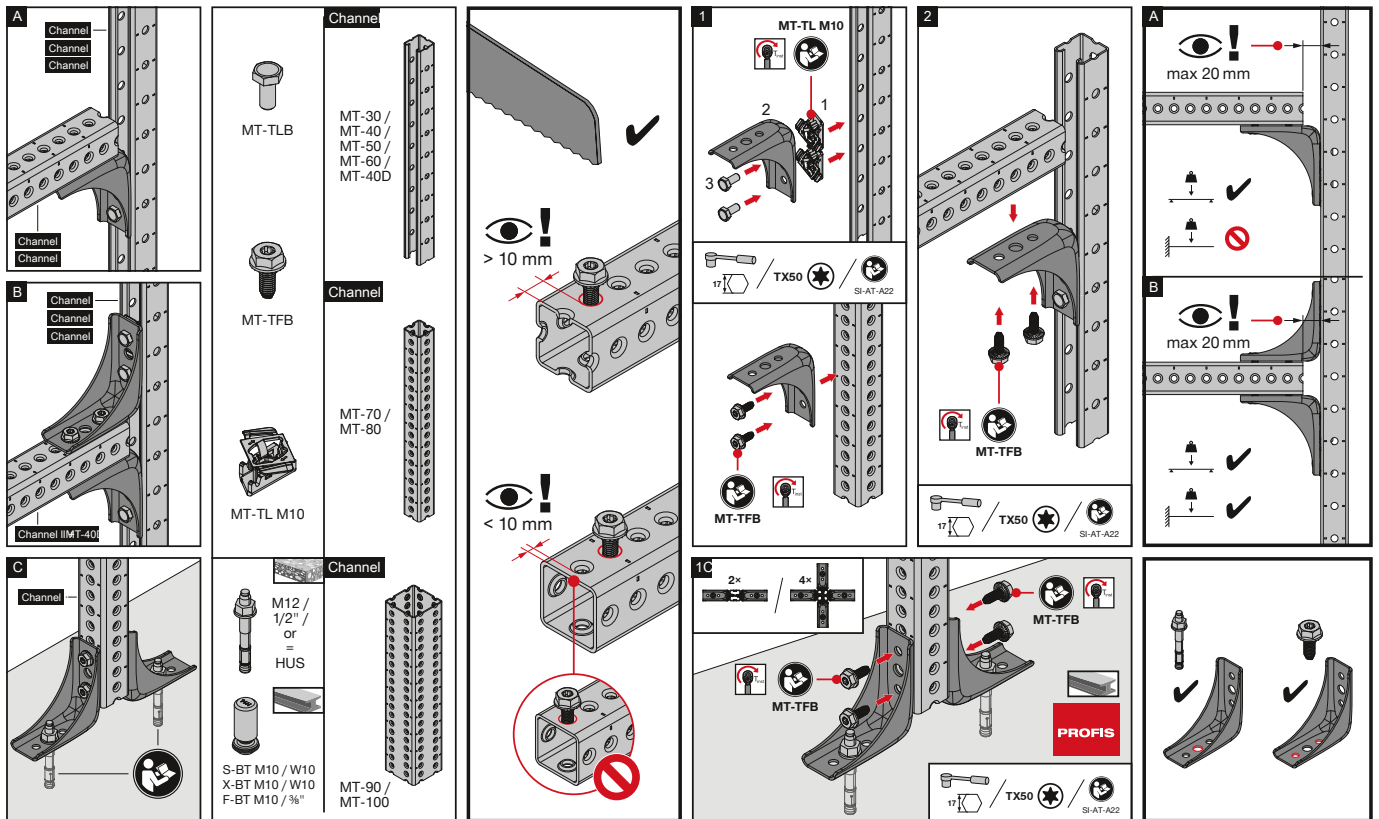

The latest IFU (Instruction for Use) is available on Hilti Online. Please check for any revisions before installing the product.

MT-C-GS A OC

2289567-09.2020

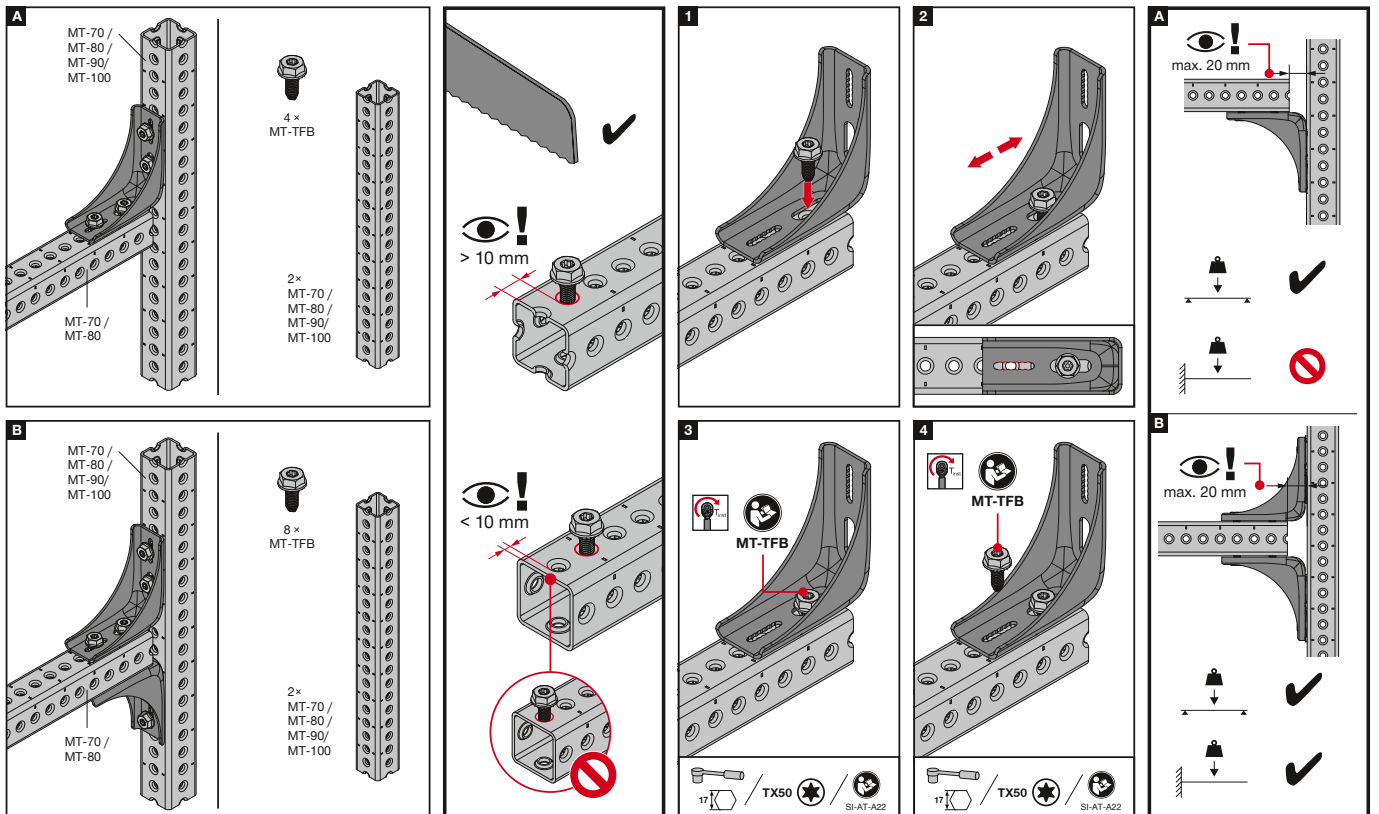

The latest IFU (Instruction for Use) is available on Hilti Online. Please check for any revisions before installing the product.

MT Box Profiles Connectors

90° Connectors - Outdoor

Operation Instruction

MT-C-GL OC

2289566-07.2020

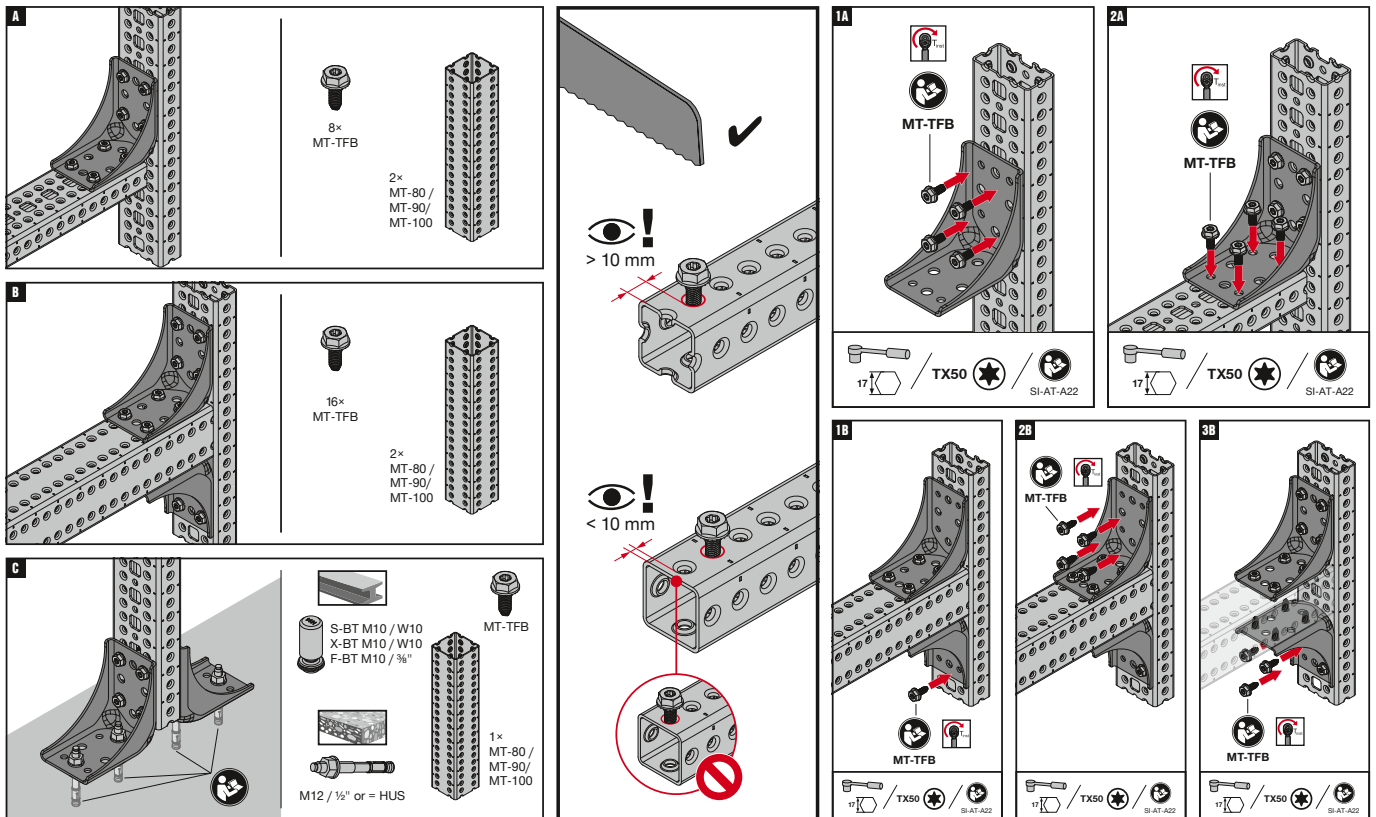

The latest IFU (Instruction for Use) is available on Hilti Online. Please check for any revisions before installing the product.

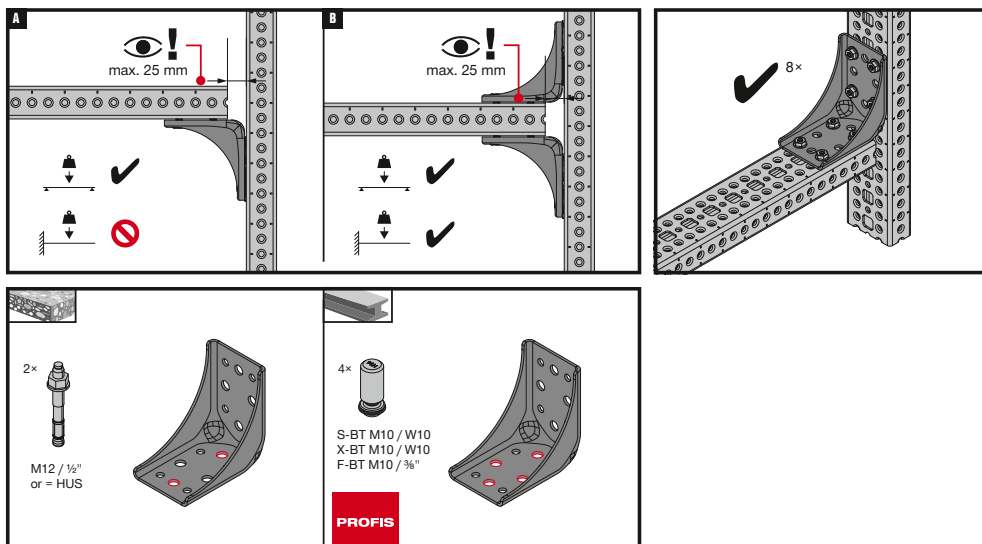
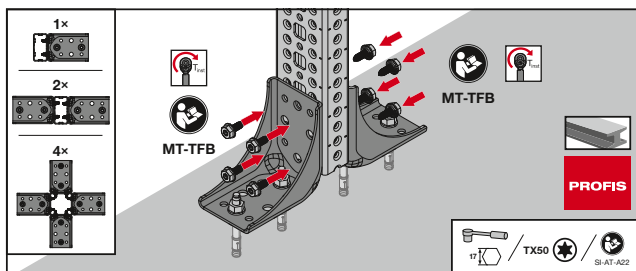

The latest IFU (Instruction for Use) is available on Hilti Online. Please check for any revisions before installing the product.

MT Box Profiles Connectors

90° Connectors - Outdoor

4

Operation Instruction MT-C-GL A OC

2289568-09.2020

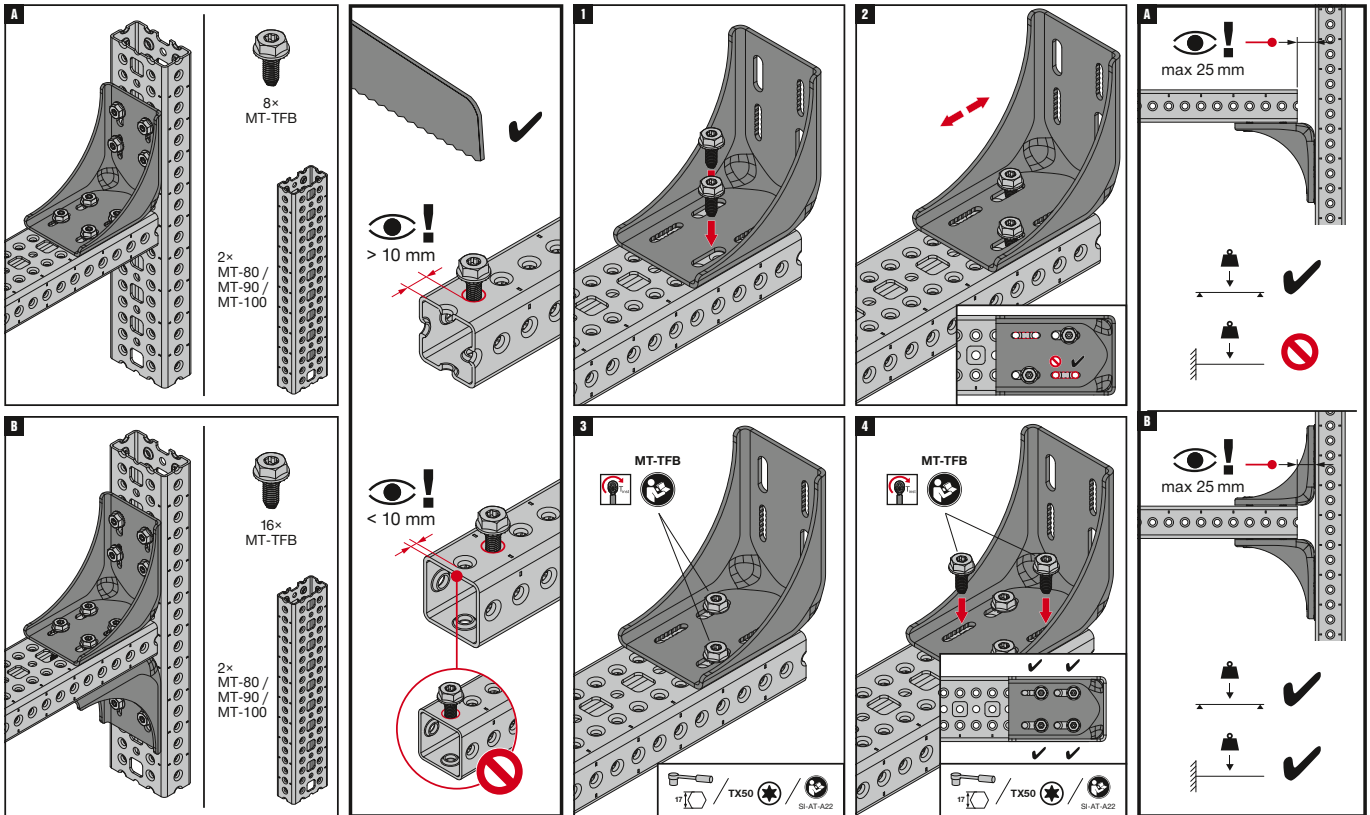

The latest IFU (Instruction for Use) is available on Hilti Online. Please check for any revisions before installing the product.

MT Box Profiles Connectors
90° Connectors - Outdoor

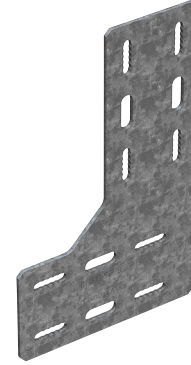

Applications

- Assembling and bracing modular support structures consisting of MT-70, MT-80, MT-90(H) or MT-100 Box Profiles
- Multidisciplinary MEP support structures combining a wide range of Media such as air ducts, cable trays, piping, etc.
- Ceiling-mounted MEP support structures with heavy loads such as ceiling grids and utility piping and drainage

Advantages

- Faster to install – one-step assembly using Hilti MT Thread forming Bolts (MT-TFB) and compatible with the Hilti Adaptive Torque system for hassle-free installations (compatible tool and SI-AT module required)
- Versatile and secure connections - use vertical oblong holes to adjust height in 5mm (1/4") increments and cloud holes with thread forming bolts (MT-TFB) for secure connections between MTheavy Boxed Profiles
- Adaptable – unlike welding, gusset plates allow modular metal framing to be modified during installation and for future MEP requirements
- Part of the Hilti MT System – an economical, all-in-one solution for virtually all modular MEP support structures

Technical Data

Material composition	Q355 or better steel
Surface finish	Hot-dip galvanized - for outdoor use

MT-C-GSP L OC Connector - Outdoor

Order Designation	Technical Data	Sales pack Quantity	Item number	
MT-C-GSP L OC	Outdoor, low to moderate pollution (C3 / C4 - low)	10 pc	2272073	

MT-C-GSP L A OC Connector - Outdoor

Order Designation	Technical Data	Sales pack Quantity	Item number	
MT-C-GSP L A OC	Outdoor, low to moderate pollution (C3 / C4 - low)	10 pc	2332786	

MT Box Profiles Connectors

90° Connectors - Outdoor

4

MT-C-GSP T OC Angle Connector - Outdoor

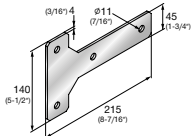
Order Designation	Technical Data	Sales pack Quantity	Item number	
MT-C-GSP T OC	Outdoor, low to moderate pollution (C3 / C4 - low)	10 pc	2272074	

MT-C-GSP T A OC Angle Connector - Outdoor

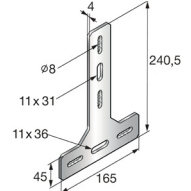
Order Designation	Technical Data	Sales pack Quantity	Item number	
MT-C-GSP T A OC	Outdoor, low to moderate pollution (C3 / C4 - low)	10 pc	2332785	

MT-C-GLP T OC Angle Connector - Outdoor

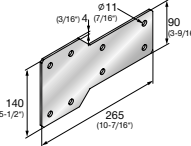
Order Designation	Technical Data	Sales pack Quantity	Item number	
MT-C-GLP T OC	Outdoor, low to moderate pollution (C3 / C4 - low)	8 pc	2272075	

MT-C-GLP T A OC Angle Connector - Outdoor

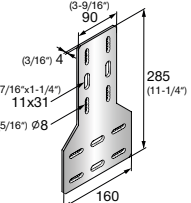
Order Designation	Technical Data	Sales pack Quantity	Item number	
MT-C-GLP T A OC	Outdoor, low to moderate pollution (C3 / C4 - low)	8 pc	2332784	

MT-C-GLP X A OC Angle Connector - Outdoor

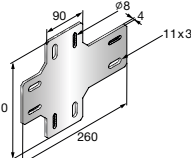
Order Designation	Technical Data	Sales pack Quantity	Item number	
MT-C-GLP X A OC	Outdoor, low to moderate pollution (C3 / C4 - low)	10 pc	2332783	

MT-C-GLP L A OC Angle Connector - Outdoor

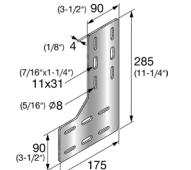
Order Designation	Technical Data	Sales pack Quantity	Item number	
MT-C-GLP L A OC	Outdoor, low to moderate pollution (C3 / C4 - low)	8 pc	2430769	

MT Box Profiles Connectors

90° Connectors - Outdoor

4

Technical Data MT Connectors

Item image	Load drawing	Order Designation	+ Fz	- Fz	± Fx	± Fy
		MT-C-GSP T OC	7,1 kN	7,1 kN	46,7 kN	5,9 kN

Design notes

- Shown load values are recommended values with partial safety factors for actions and resistance included
- Design value = 1,4 * recommended value
- The design resistance of the products is defined in accordance with EN1993

Technical Data MT Connectors

Item image	Load drawing	Order Designation	+ Fz	- Fz	± Fx	± Fy
		MT-C-GSP L A OC	14,0 kN	14,3 kN	19,8 kN	2,6 kN
		MT-C-GSP L OC	10,9 kN	11,1 kN	13,7 kN	3,5 kN
		MT-C-GSP T A OC	16,8 kN	16,8 kN	33,4 kN	2,1 kN
		MT-C-GLP T OC	25,0 kN	25,0 kN	86,7 kN	8,4 kN

Design notes

- Shown load values are recommended values with partial safety factors for actions and resistance included
- Design value = 1,5 * recommended value
- The design resistance of the products is defined in accordance with EN1993

MT Box Profiles Connectors

90° Connectors - Outdoor

4

Technical Data MT Connectors

Item image	Load drawing	Order Designation	+ Fz	- Fz	± Fx	± Fy
		MT-C-GLP T A OC	24,7 kN	24,7 kN	66,1 kN	4,3 kN
		MT-C-GLP X A OC	12,7 kN	12,7 kN	7,8 kN	3,7 kN
		MT-C-GLP L A OC	15,3 kN	15,2 kN	28,2 kN	3,4 kN

Design notes

- Shown load values are recommended values with partial safety factors for actions and resistance included
- Design value = 1,5 * recommended value
- The design resistance of the products is defined in accordance with EN1993

MT Box Profiles Connectors

90° Connectors - Outdoor

4

Operation Instruction MT-C-GSP L OC

2289569-07.2020

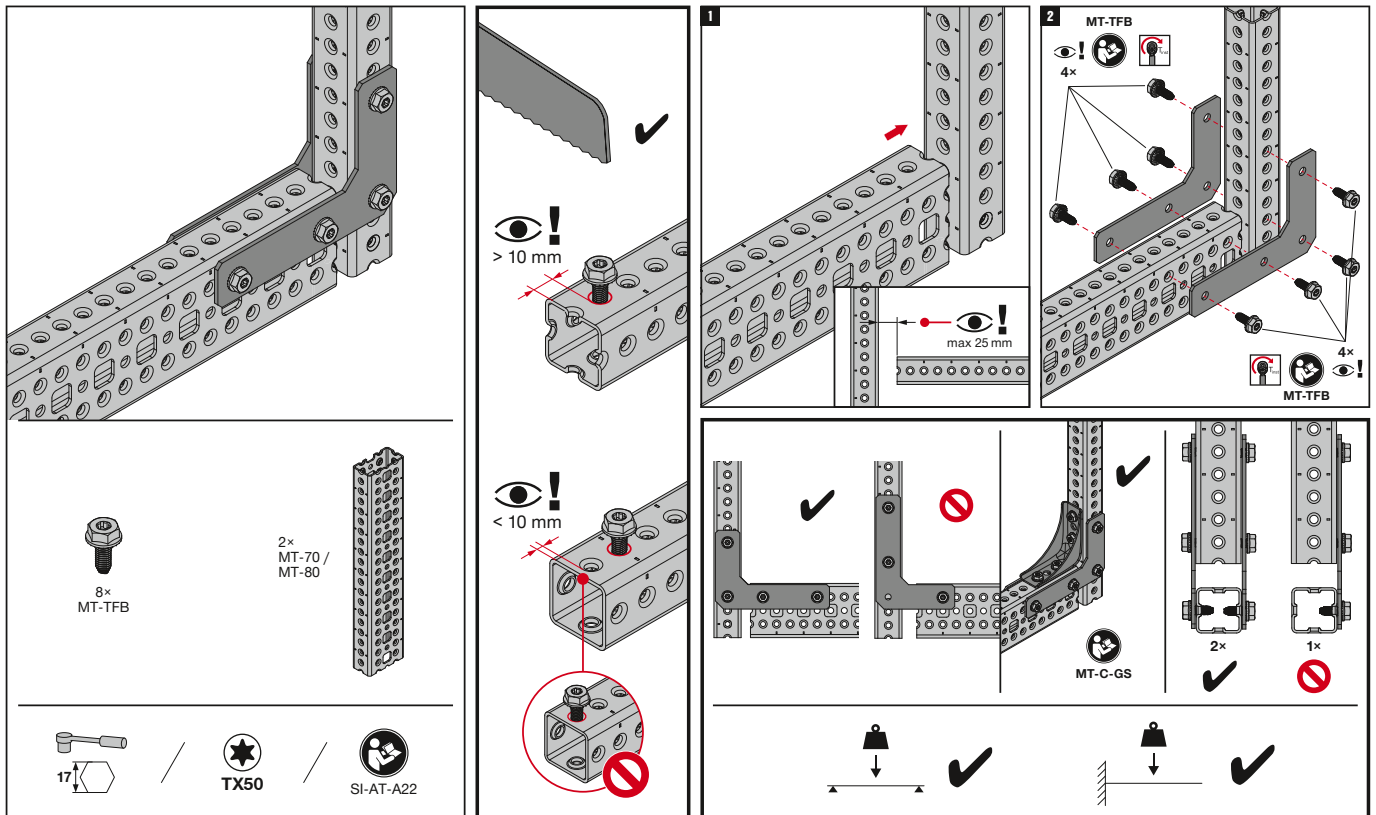

The latest IFU (Instruction for Use) is available on Hilti Online. Please check for any revisions before installing the product.

MT-C-GSP L A OC

2334573-07.2021

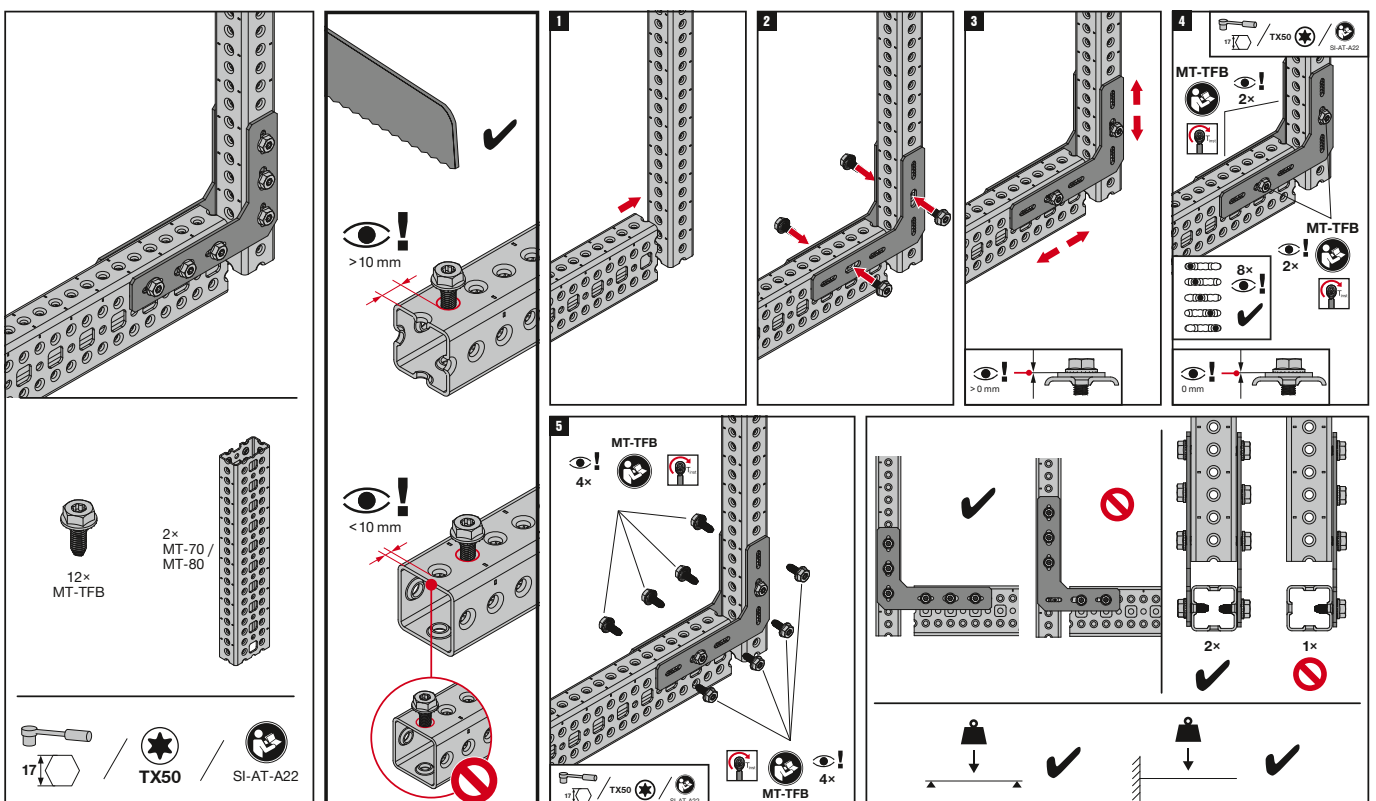

The latest IFU (Instruction for Use) is available on Hilti Online. Please check for any revisions before installing the product.

MT Box Profiles Connectors

90° Connectors - Outdoor

Operation Instruction MT-C-GSP T OC

2290690-06.2020

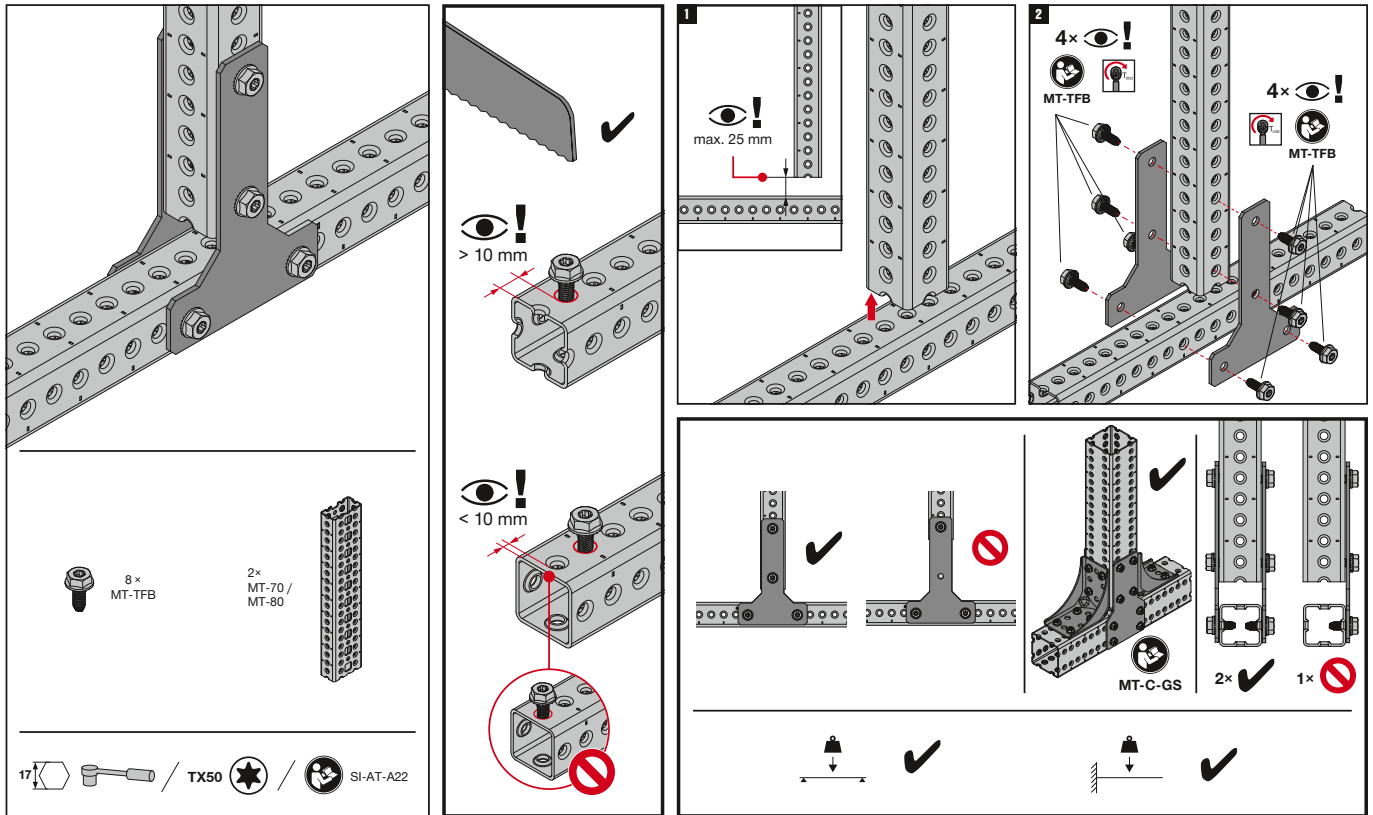

The latest IFU (Instruction for Use) is available on Hilti Online. Please check for any revisions before installing the product.

MT-C-GSP T A OC

2334586-07.2021

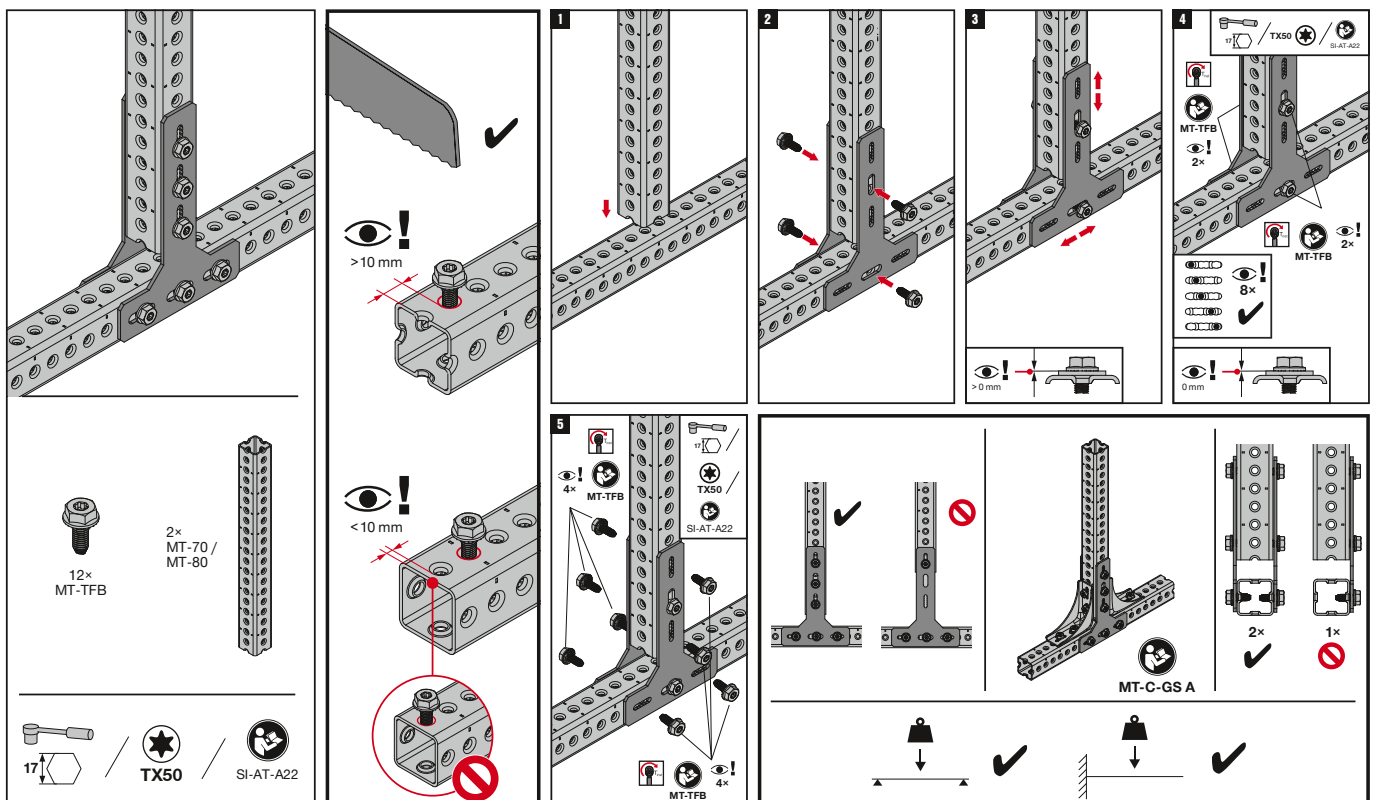

The latest IFU (Instruction for Use) is available on Hilti Online. Please check for any revisions before installing the product.

MT Box Profiles Connectors

90° Connectors - Outdoor

4

Operation Instruction MT-C-GLP T OC

2290691-06.2020

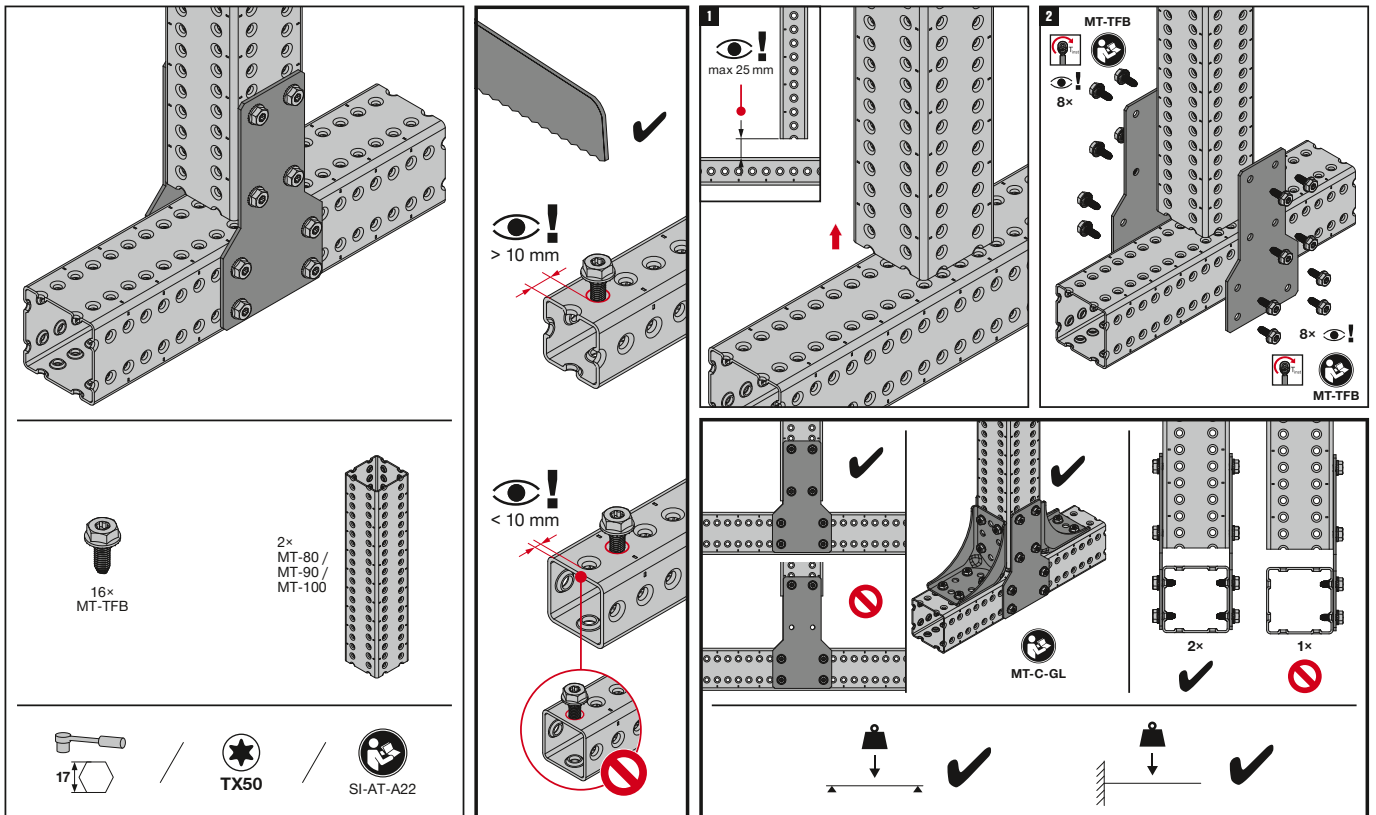

The latest IFU (Instruction for Use) is available on Hilti Online. Please check for any revisions before installing the product.

MT-C-GLP T A OC

2334585-07.2021

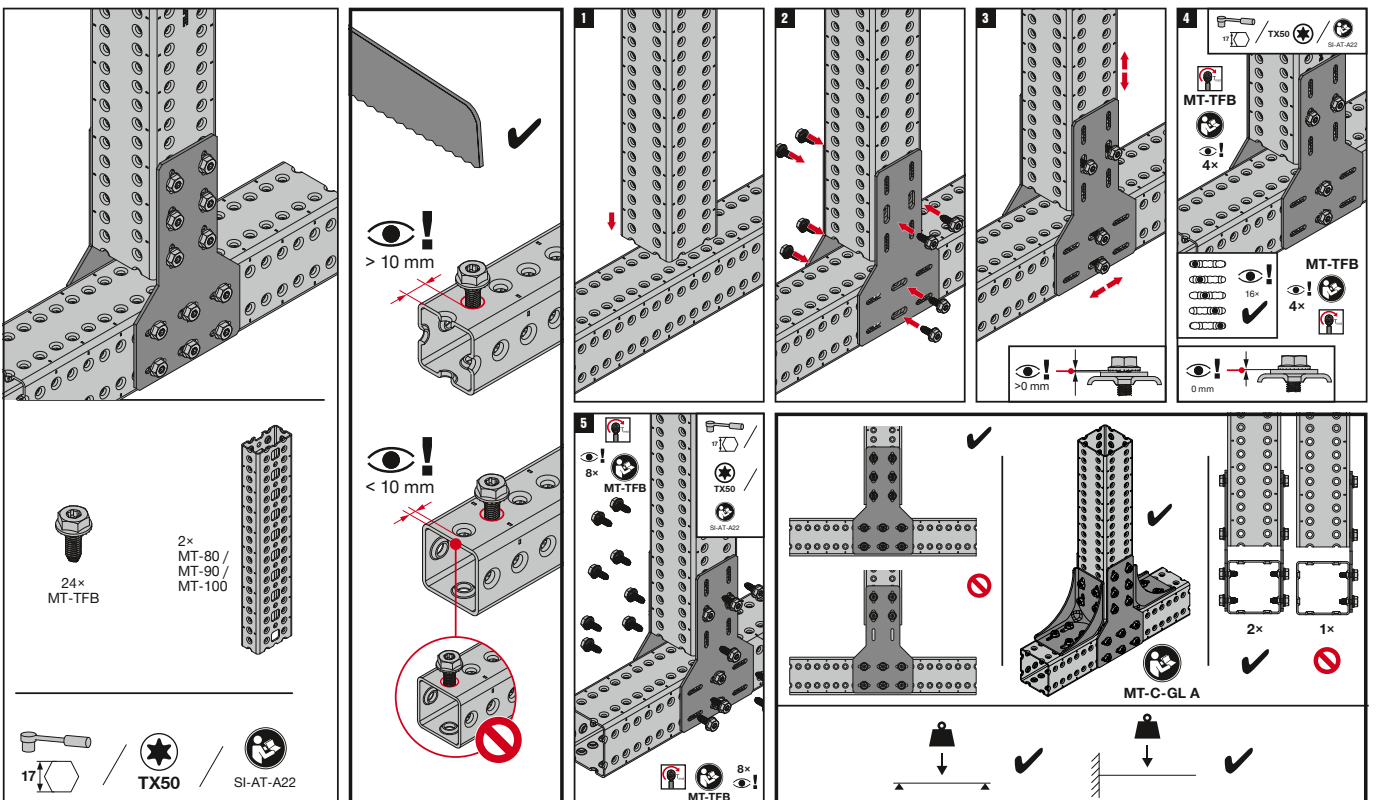

The latest IFU (Instruction for Use) is available on Hilti Online. Please check for any revisions before installing the product.

MT Box Profiles Connectors

90° Connectors - Outdoor

4

Operation Instruction MT-C-GLP X A OC

2334584-07.2021

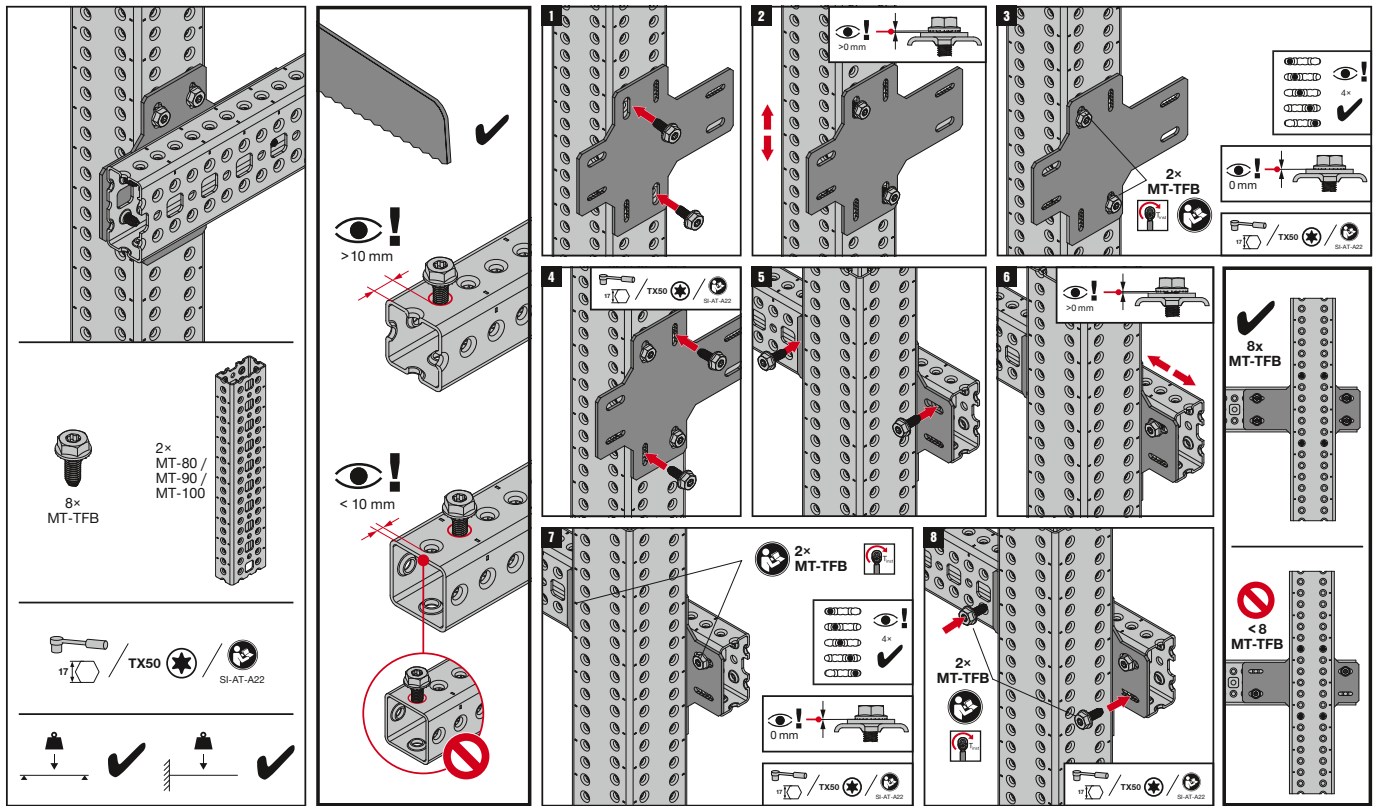

The latest IFU (Instruction for Use) is available on Hilti Online. Please check for any revisions before installing the product.

MT-C-GLP L A OC

2436649-04.2024

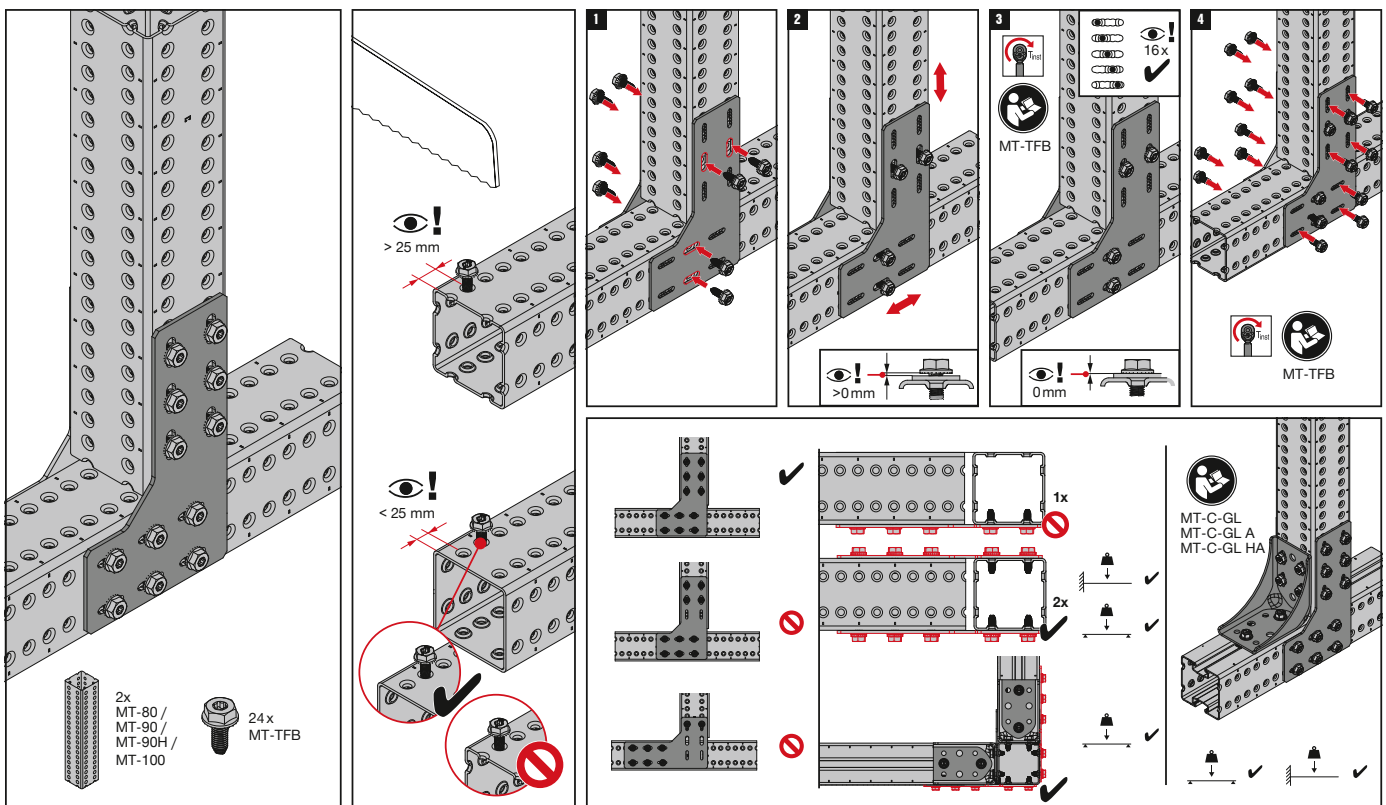

The latest IFU (Instruction for Use) is available on Hilti Online. Please check for any revisions before installing the product.

MT Box Profiles Connectors

90° Connectors - Outdoor

4

Operation Instruction MT-C-GL HA OC

2436827-04.2024

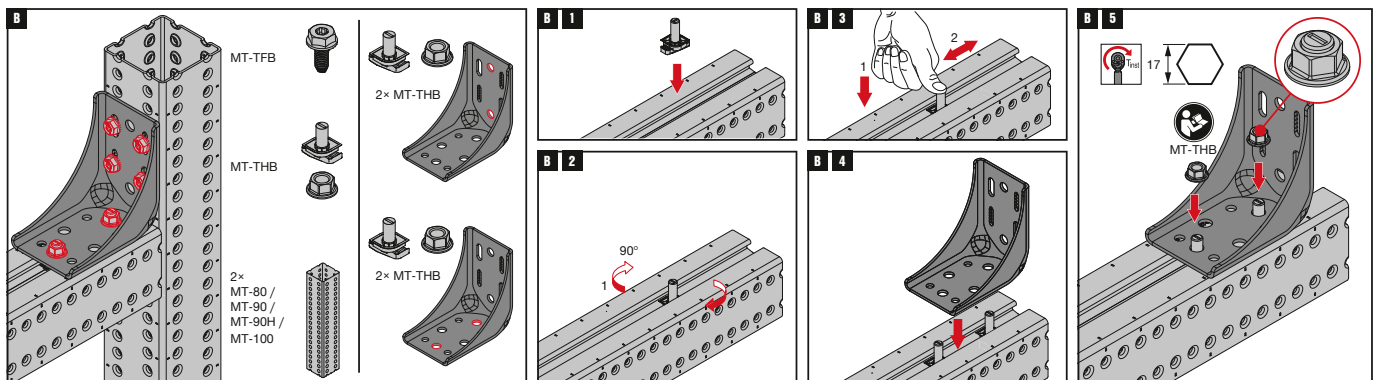
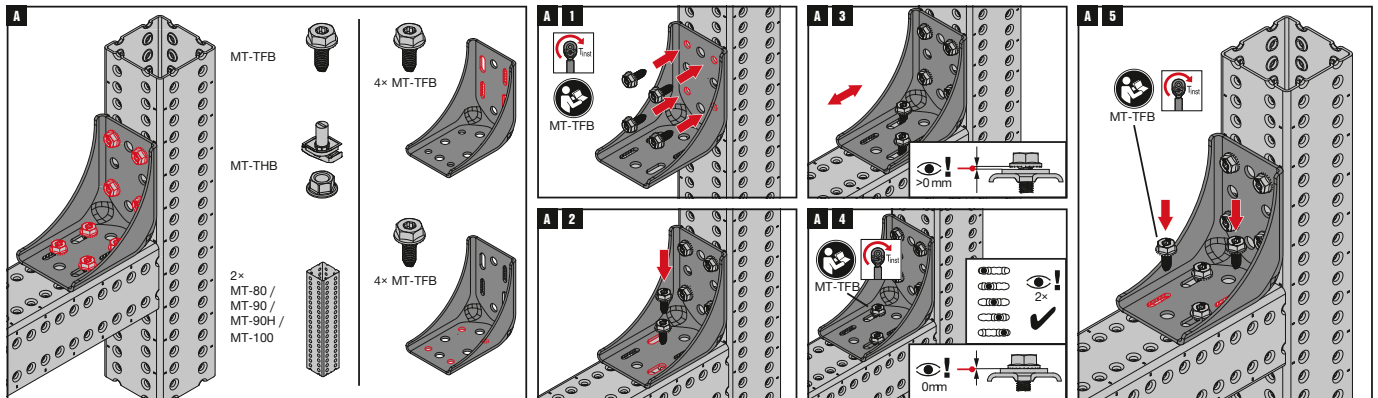

The latest IFU (Instruction for Use) is available on Hilti Online. Please check for any revisions before installing the product.

MT-C-GS HA OC

2436931-05.2024

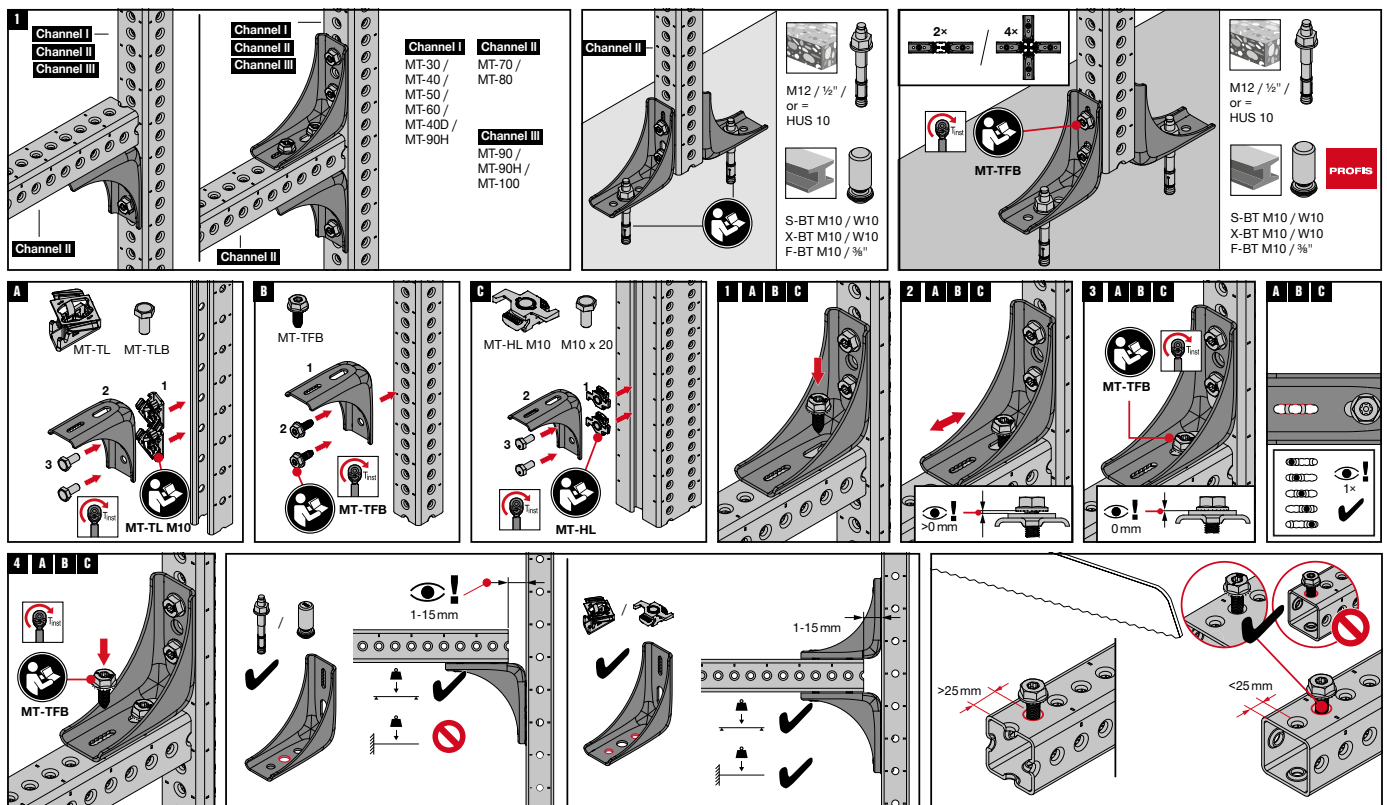

The latest IFU (Instruction for Use) is available on Hilti Online. Please check for any revisions before installing the product.

MT Box Profiles Connectors

Splice Connectors - Outdoor

4

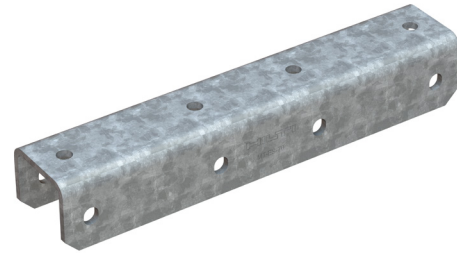

Applications

- Extending MT-70 or MT-80 Box Profiles by fastening them together end-to-end
- Assembling metal framing for MEP support structures when longer spans or increased floor/ceiling clearance are required
- Suitable for use in moderately corrosive environments

Advantages

- Part of the Hilti MT system – an economical, all-in-one solution for virtually all modular MEP support structures
- Easy to install – one-step assembly using Hilti MT-TFB thread-forming bolts
- Adaptable – unlike welding, splice clevises allow modular metal framing to be modified for future MEP requirements

Technical Data

Material composition	Q355 or better steel
Surface finish	Hot-dip galvanized - for outdoor use

MT-ES-70 OC Splice Connector - Outdoor

Order Designation	Technical Data	Sales pack Quantity	Item number	
MT-ES-70 OC	Outdoor, low to moderate pollution (C3 / C4 - low)	8 pc	2272078	

MT-ES-90 OC Splice Connector - Outdoor

Order Designation	Technical Data	Sales pack Quantity	Item number	
MT-ES-90 OC	Outdoor, low to moderate pollution (C3 / C4 - low)	4 pc	2272076	

MT Box Profiles Connectors

Splice Connectors - Outdoor

4

Technical Data MT Splice Connector

Item image	Load drawing	Order Designation	+ Fz	- Fz	± Fx	± Fy	± My
		MT-ES-70 OC	1,7 kN	1,7 kN	26,3 kN	2,3 kN	1,63 kNm
		MT-ES-90 OC	5,0 kN	4,7 kN	44,3 kN	4,7 kN	3,5 kNm

Design notes

- Shown load values are recommended values with partial safety factors for actions and resistance included
- Design value = 1,5 * recommended value
- The design resistance of the products is defined in accordance with EN1993

MT Box Profiles Connectors

Splice Connectors - Outdoor

4

Operation Instruction

MT-ES-70 OC

2290693-06.2020

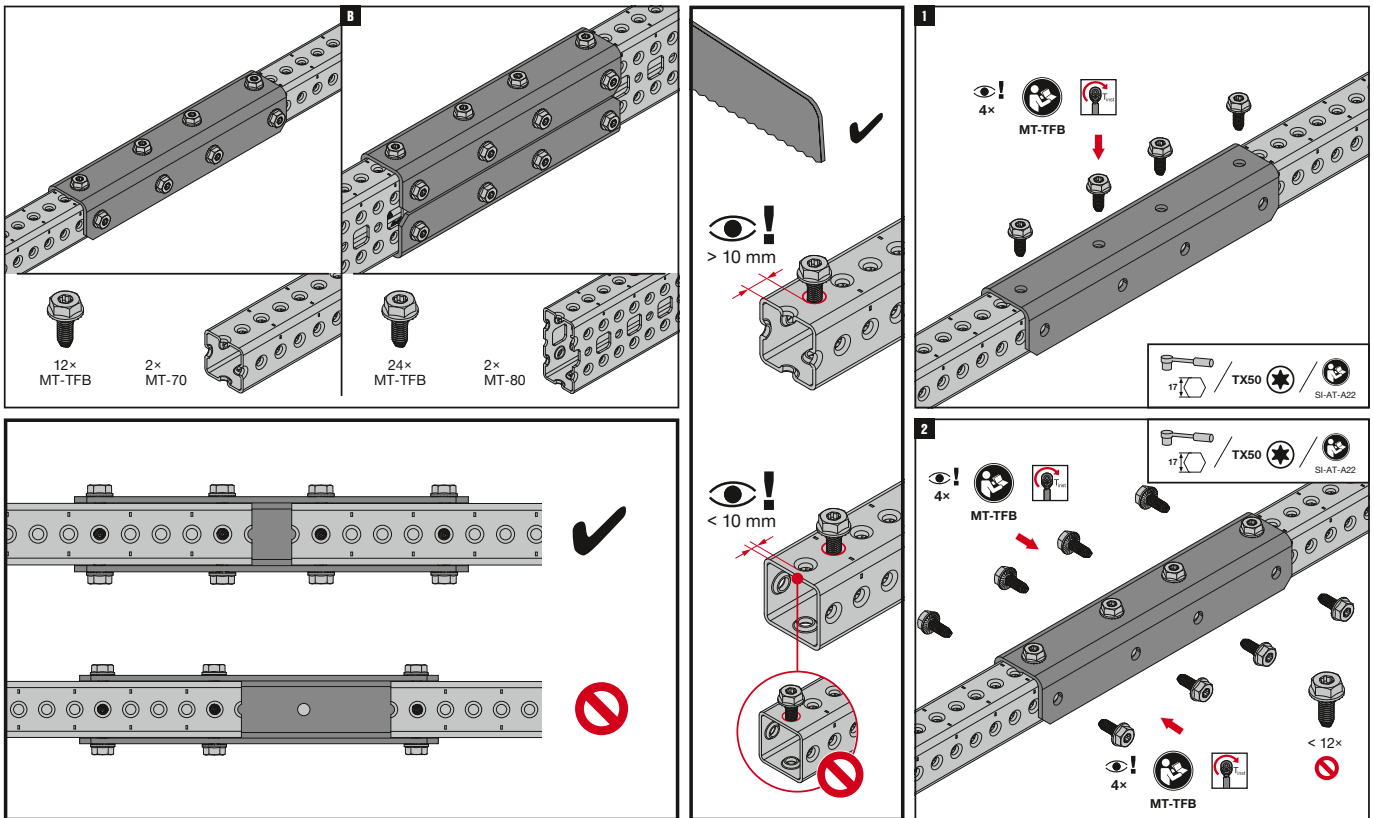

The latest IFU (Instruction for Use) is available on Hilti Online. Please check for any revisions before installing the product.

MT-ES-90 OC

2290692-06.2020

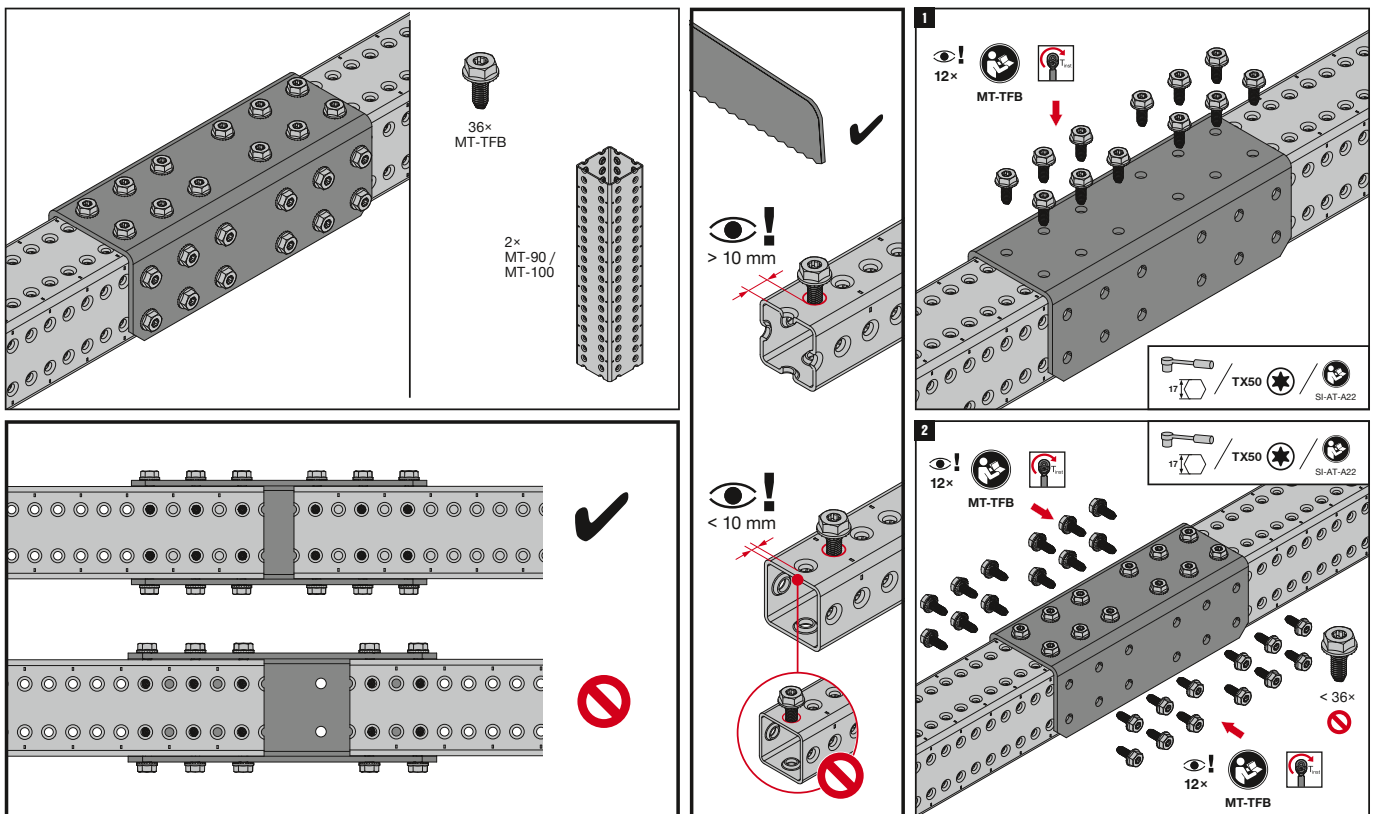

The latest IFU (Instruction for Use) is available on Hilti Online. Please check for any revisions before installing the product.

MT Channel Clamp - Outdoor

4

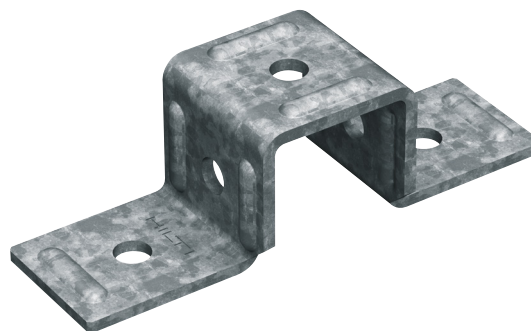
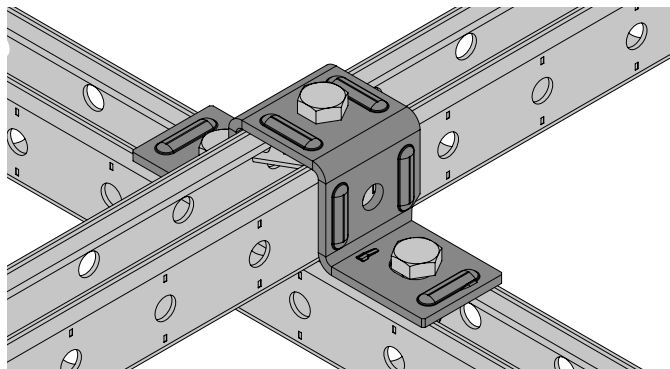

Applications

- Cross-connection of one C-girder to another Channel or girder
- Suitable for use in moderately corrosive environments

Technical Data

Material composition	Q235 or better steel
Surface finish	Hot-dip galvanized - for outdoor use

Advantages

- Compatible with MT Twist-Lock and MT Thread forming Bolt Channel Connectors – for much faster, adaptable assembly
- Universal – complete many different Applications using few parts
- Twist-lock and Thread forming Bolt Channel Connector takes up shear and tensile loads

MT-CC-70 OC Channel Clamp - Outdoor

Order Designation	Technical Data	Sales pack Quantity	Item number	
MT-CC-70 OC	Outdoor, low to moderate pollution (C3 / C4 - low)	16 pc	2322404	

Technical Data Channel Clamp

Item image	Load drawing	Order Designation	+ Fz	- Fz	± Fx	± Fy
		MT-CC-70 OC	-	5,4 kN	2,5 kN	3,6 kN

Design notes

- Shown load values are recommended values with partial safety factors for actions and resistance included
- Design value = 1.4 * recommended value
- The design resistance of the products is defined in accordance with EN1993

MT Channel Clamps - Outdoor

4

Operation Instruction MT-CC-70

232516-04.2021

CC	CI	CII	
MT-CC-30	MT-30	1x MT-TLB	1x MT-TLB
MT-CC-30D	MT-30D		
MT-CC-55	MT-55	1x MT-TL M10	2x MT-TL M10
MT-CC-55D	MT-55D		
MT-CC-60	MT-60	1x MT-TFB	2x MT-TL M10
MT-CC-70	MT-70		

CC	CI	CII	
MT-CC-30	MT-30	1x MT-TLB	2x MT-TFB
MT-CC-30D	MT-30D		
MT-CC-55	MT-55	1x MT-TL M10	1x MT-TFB
MT-CC-55D	MT-55D		
MT-CC-60	MT-60	1x MT-TFB	1x MT-TFB
MT-CC-70	MT-70		

The latest IFU (Instruction for Use) is available on Hilti Online. Please check for any revisions before installing the product.

MT Box Profiles Connectors

Brace Connectors - Outdoor

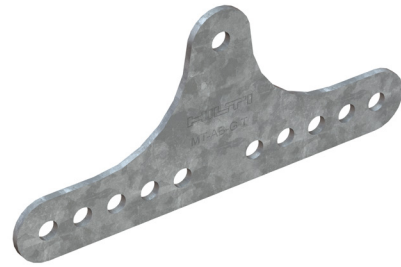
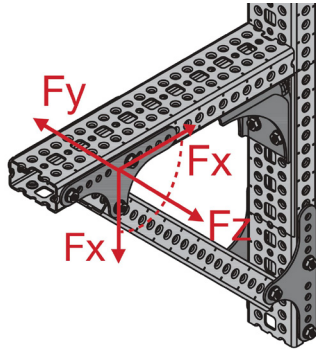

Applications

- Creating a pivoting connection between two MT Box Profiles
- Bracing metal framing and MEP support structures
- Suitable for use in moderately corrosive environments

Advantages

- Part of the Hilti MT system – an economical, all-in-one solution for virtually all modular MEP support structures
- Adaptable – unlike welding, modular metal framing can be modified for future MEP requirements
- Extensive software support – PROFIS Modular Support Engineering, the MEP Support Selector, Revit® families, and plug-ins for Staad Pro® and Smart 3D® are all available to streamline design and ordering

Technical Data

Material composition	Q355 or better steel
Surface finish	Hot-dip galvanized - for outdoor use

MT-AB-G T OC Angle Brace - Outdoor

Order designation	Technical Data	Sales pack Quantity	Item number	
MT-AB-G T OC	Outdoor, low to moderate pollution (C3 / C4 - low)	4 pc	2272116	

Technical Data Angle Brace

Item image	Load drawing	Order Designation	+ Fz	- Fz	± Fx	± Fy
		MT-AB-G T / MT-AB-G T OC	4,3 kN	4,3 kN	21,4 kN	-

Design notes

- Shown load values are recommended values with partial safety factors for actions and resistance included
- Design value = 1.5 * recommended value
- The design resistance of the products is defined in accordance with EN1993

MT Box Profiles Connectors

Brace Connectors - Outdoor

4

Operation Instruction

MT-AB-G T OC

2294697-06.2020

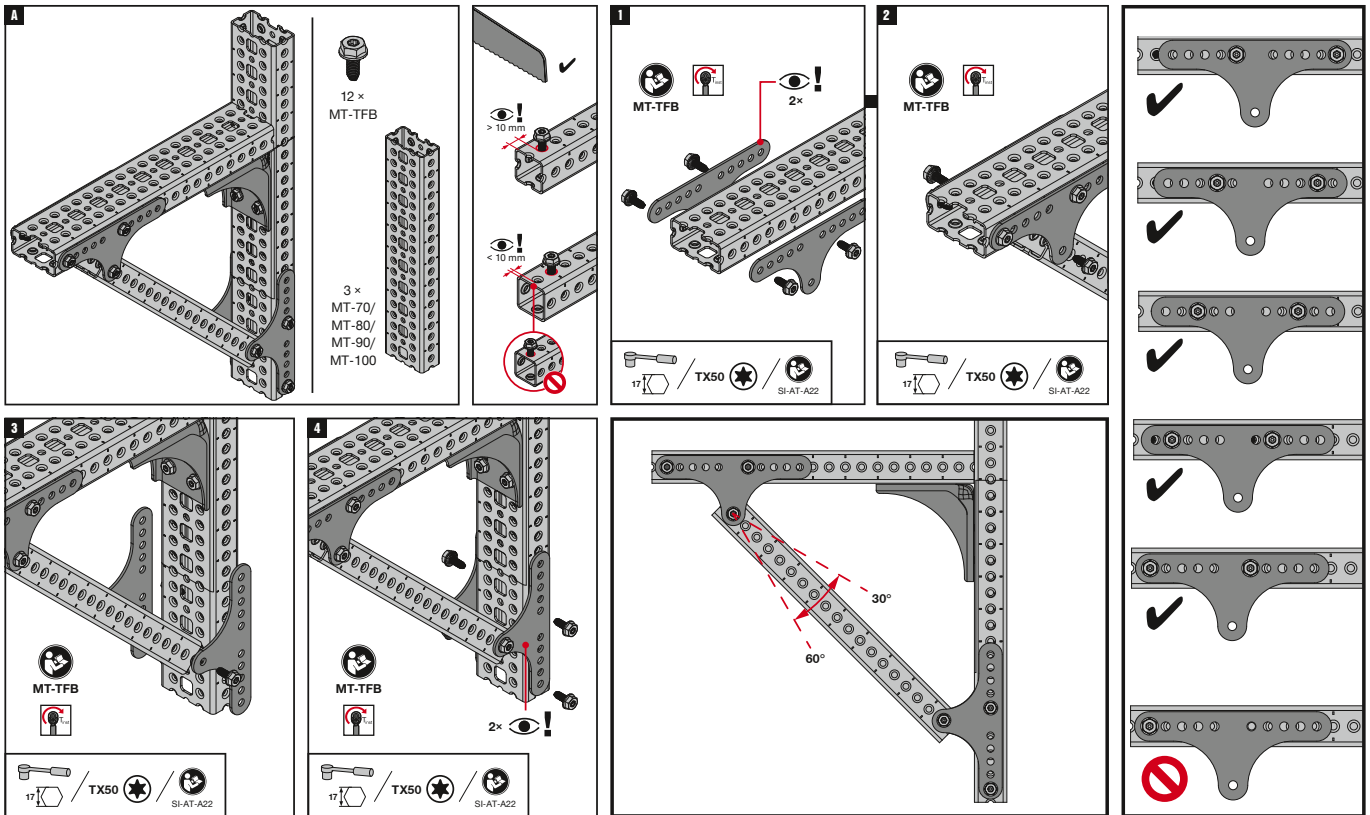

The latest IFU (Instruction for Use) is available on Hilti Online. Please check for any revisions before installing the product.

MT Box Profiles Connectors

T-beam - Outdoor

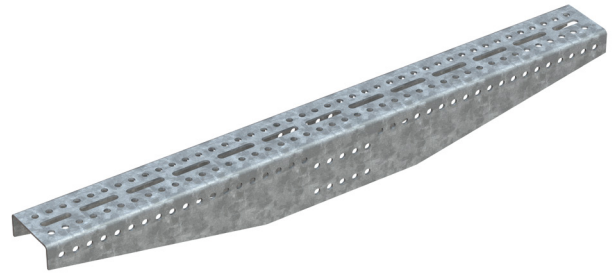

Applications

- Constructing T-beams to support heavy-duty MEP installations by fastening to an upright MT-90 or MT-100 Box Profile
- Suitable for use in moderately corrosive environments

Advantages

- Part of the Hilti MT system – an economical, all-in-one solution for virtually all modular MEP support structures
- Easy to install – one-step assembly using Hilti MT-TFB thread-forming bolts
- Optimized load-to-weight ratio – engineered for maximum pipe ring/cable tray capacity with minimum self-weight

Technical Data

Material composition	Q355 or better steel
Surface finish	Hot-dip galvanized - for outdoor use

MT-U-GL1 OC T-beam - Outdoor

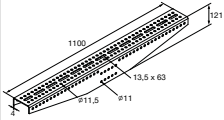
Order Designation	Technical Data	Sales pack Quantity	Item number	
MT-U-GL1 OC	Outdoor, low to moderate pollution (C3 / C4 - low)	2 pc	2272070	

Technical Data T-beam

Item image	Load drawing	Order Designation	+ Fz	- Fz	± Fx	± Fy
		MT-U-GL1 OC	23,8 kN	23,8 kN	68,8 kN	6,8 kN

Design notes

- Shown load values are recommended values with partial safety factors for actions and resistance include
- Design value = 1.5 * recommended value
- The design resistance of the products is defined in accordance with EN1993

MT Box Profiles Connectors

T-beam Outdoor

Operation Instruction

MT-C-U-GL 1 OC

2312252-09.2020

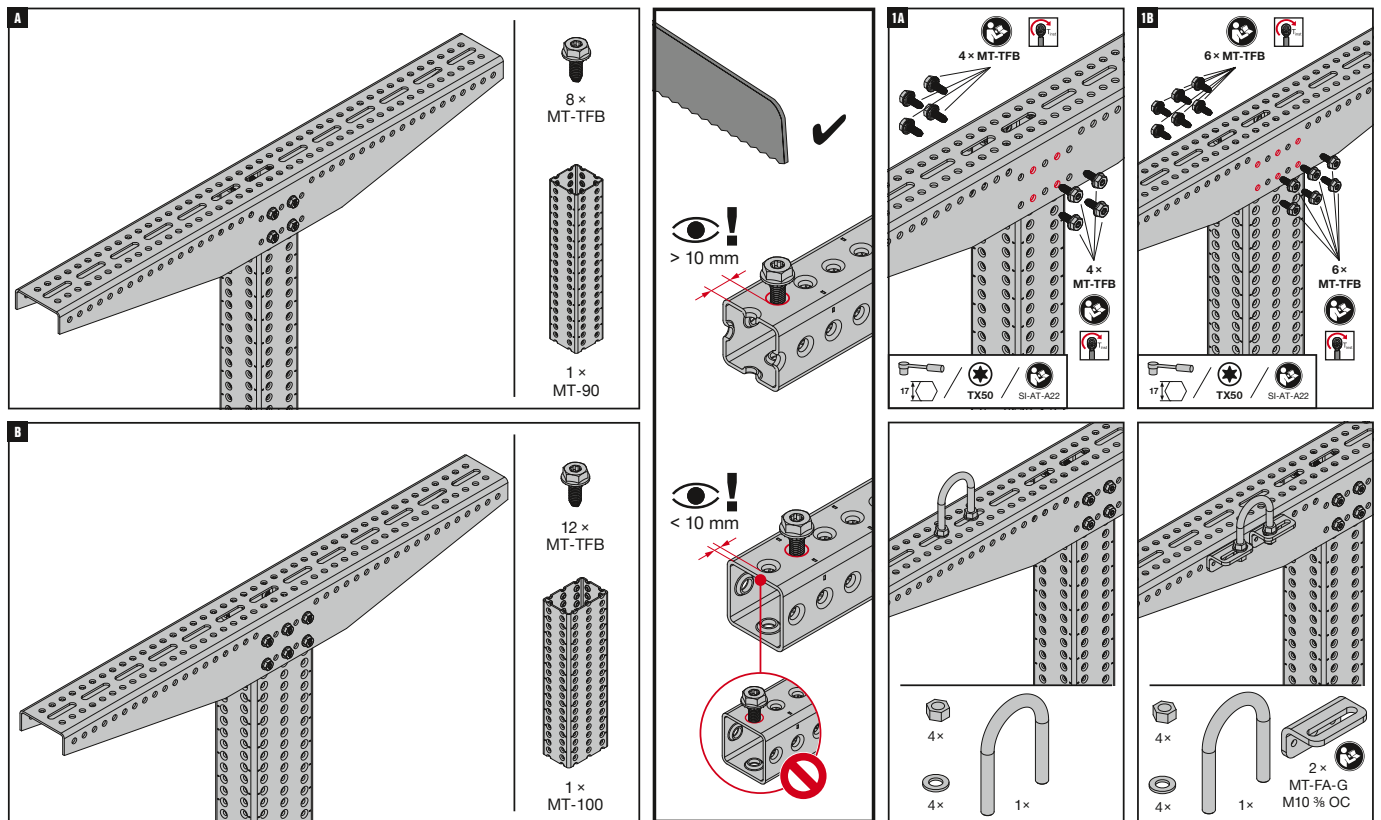

The latest IFU (Instruction for Use) is available on Hilti Online. Please check for any revisions before installing the product.

MT Box Profiles Connectors

Threaded Rod Guide

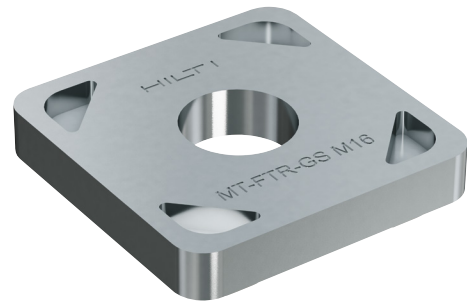
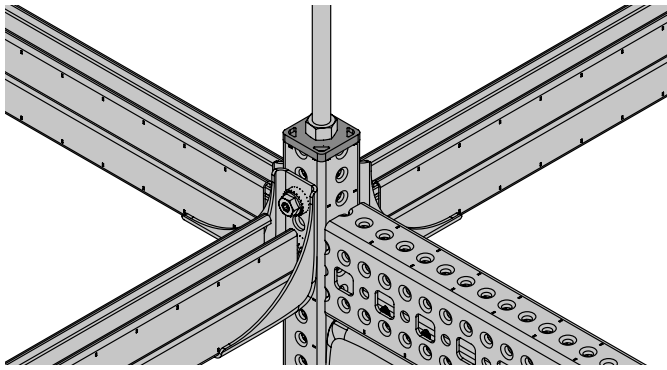

Applications

- Closing the 2 ends of a MT-70 Box Profile
- Building the core of overhead grids
- Suitable for use in dry, indoor environments

Advantages

- Easy to install – adjustable, modular system
- Flexible – overhead grid system offers you high flexibility in terms of number and type of Profiles to be used
- Extensive software support – PROFIS Modular Support Engineering, the MEP Support Selector, Revit® families, and plug-ins for Staad Pro® and Smart 3D® are all available to streamline design and ordering

Technical Data

Material composition	Q235 or better steel
Surface finish	Indoor Coated - Electro galvanized

MT-FTR-GS M12 / M16 Threaded Rod Guide

Order designation	Technical Data	Sales pack Quantity	Item number	
MT-FTR-GS M12	Dry indoor conditions (C1) Indoor with temporary condensation (C2)	15 pc	2322417	
MT-FTR-GS M16		15 pc	2322418	

MT Box Profiles Connectors
Thread forming Bolt Distance Washer

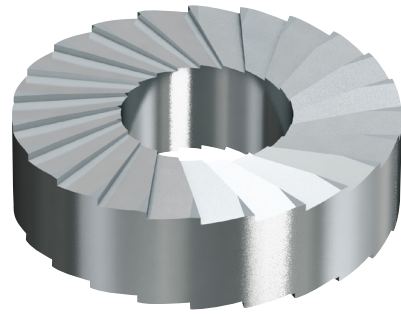
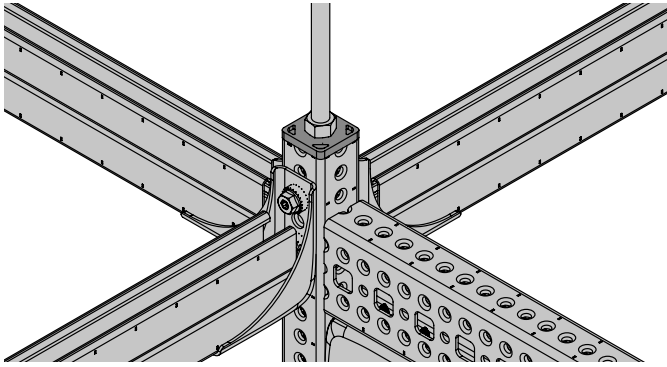

Applications

- Assembling Hilti MT modular MEP support structures

Advantages

- Part of the Hilti MT system – an economical, all-in-one solution for virtually all modular MEP support structures
- Serrated washer – better surface grip to resist loosening over time

Technical Data

Material composition	Q355 or better steel
Surface finish	Indoor Coated - Electro galvanized

MT-FTR-GSW Washer

Order designation	Technical Data	Sales pack Quantity	Item number	
MT-FTR-GSW	Dry indoor conditions (C1) Indoor with temporary condensation (C2)	20 pc	2325248	

MT Box Profiles Connectors

Threaded Rod Fixation - Outdoor

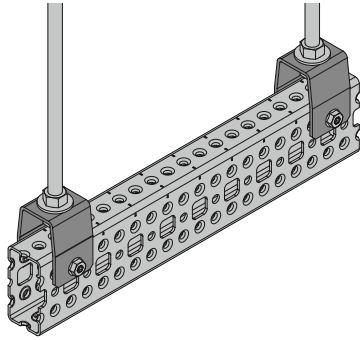

Applications

- Hanger for suspending MT-70 and MT-80 Box Profiles from threaded rod to create heavy-duty MEP and HVAC Trapeze
- Assembling Trapeze for MEP and HVAC installations subject to loads too heavy for C-Channels

Advantages

- Simpler inventory – these hangers make it possible to use standard MT Box Profiles in more situations
- Corrosion resistance – hot-dip galvanized to help protect against moisture and chemical corrosion
- Compatible with MT Thread forming Bolt Channel Connectors – for much faster, adaptable assembly

Technical Data

Material composition	Q355 or better steel
Surface finish	Hot-dip galvanized - for outdoor use

MT-CTR-GS M12 / M16 OC Threaded Rod Fixation - Outdoor

Order Designation	Technical Data	Sales pack Quantity	Item number	
MT-CTR-GS M12 OC	Outdoor, low to moderate pollution (C3 / C4 - low)	16 pc	2332789	
MT-CTR-GS M16 OC		16 pc	2332790	

MT-CTR-GL M12 / M16 OC Threaded Rod Fixation - Outdoor

Order Designation	Technical Data	Sales pack Quantity	Item number	
MT-CTR-GL M12 OC	Outdoor, low to moderate pollution (C3 / C4 - low)	16 pc	2332793	
MT-CTR-GL M16 OC		16 pc	2332796	

MT Box Profiles Connectors

Threaded Rod Guide, Threaded Rod Fixation

4

Technical Data Threaded rod guide

Item image	Load drawing	Order Designation	+ Fz	- Fz	± Fx	± Fy
		MT-FTR-GS + MT-40 D	-	2,0 kN	-	-
		MT-FTR-GS + MT-80	-	5,0 kN	-	-

Design notes

- Shown load values are recommended values with partial safety factors for actions and resistance included
- Design value = 1.4 * recommended value
- The design resistance of the products is defined in accordance with EN1993

Technical Data Threaded rod Fixation

Item image	Load drawing	Order Designation	+ Fz	- Fz	± Fx	± Fy
		MT-CTR GS M12 OC	-	11,0 kN	-	-
		MT-CTR GS M16 OC	-	11,0 kN	-	-
		MT-CTR GL M12 OC	-	15,0 kN	-	-
		MT-CTR GL M16 OC	-	15,0 kN	-	-

Design notes

- Shown load values are recommended values with partial safety factors for actions and resistance included
- Design value = 1.5 * recommended value
- The design resistance of the products is defined in accordance with EN1993

MT Box Profiles Connectors

Threaded Rod Guide

4

Operation Instruction

MT-FTR-GS M12/M16 / MT-FTR-GSW

2325320-04.2020

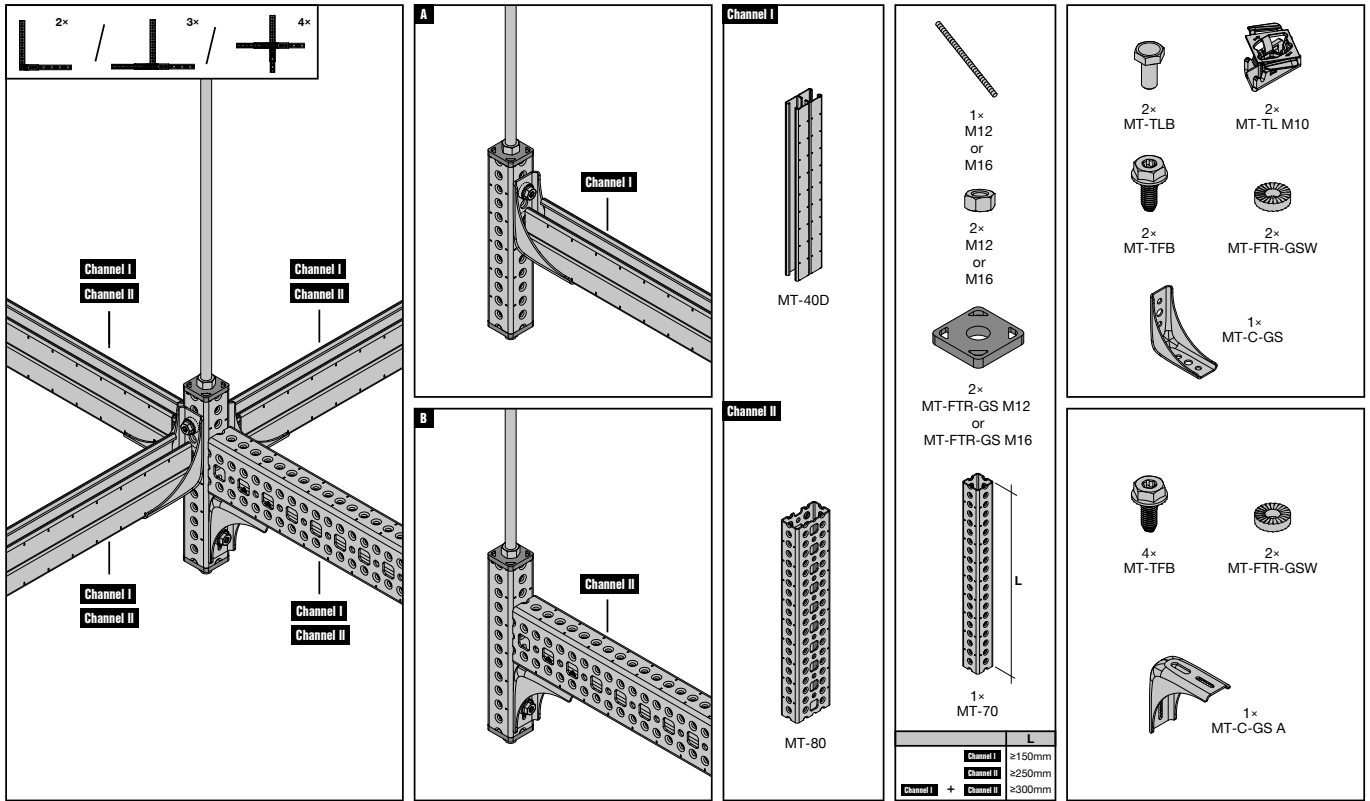

The latest IFU (Instruction for Use) is available on Hilti Online. Please check for any revisions before installing the product.

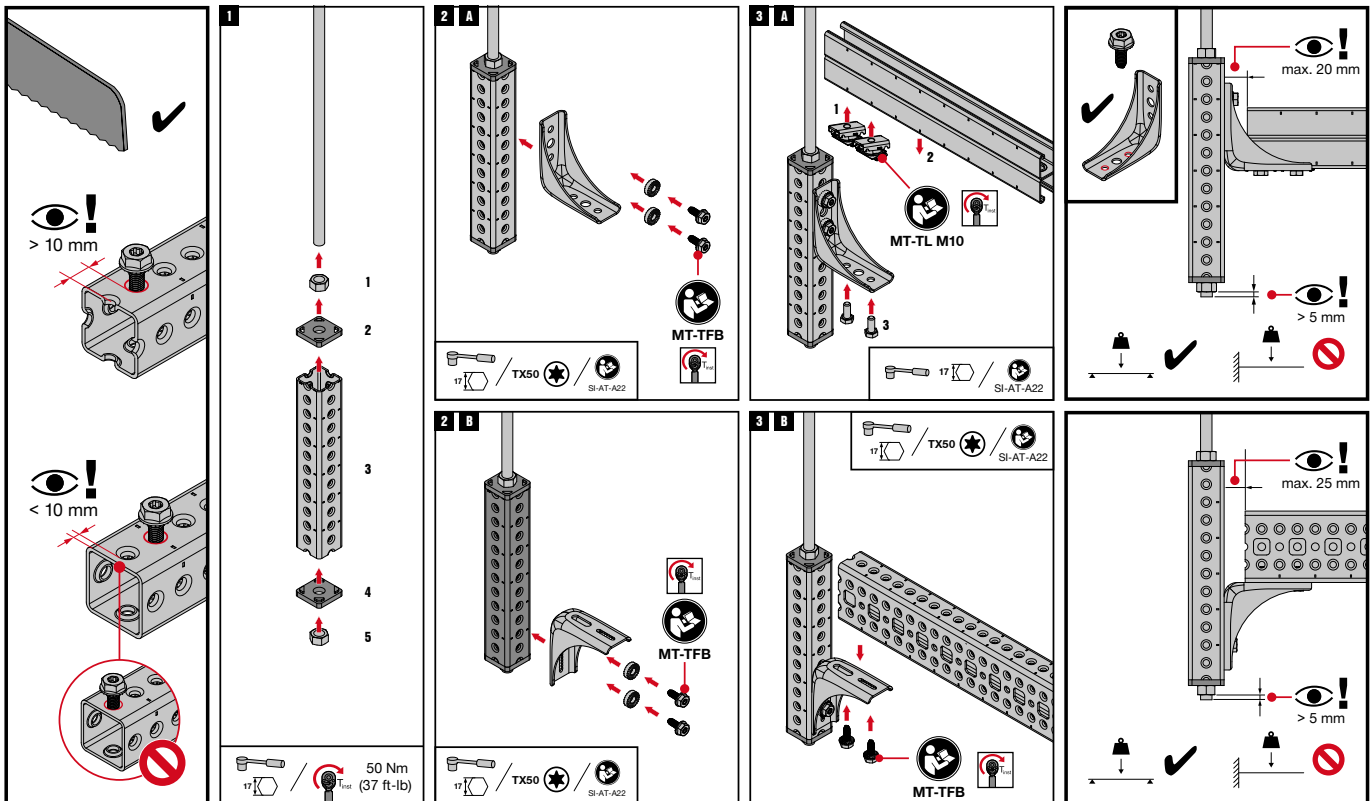

The latest IFU (Instruction for Use) is available on Hilti Online. Please check for any revisions before installing the product.

MT Box Profiles Connectors

Threaded Rod Fixation

4

Operation Instruction MT-CTR GS OC

2334574-07.2021

Set

- 2x MT-CTR GS OC Set
- 2x Nut
- 2x Washer

Extra

- 4x MT-TFB
- 2x M12 / M16 / 1/2" / 5/8"
- 1x MT-70 / MT-80

1 0mm

2

3 > 0mm

4 > 0mm

5 < 10 mm

6 MT-TFB

M12	30 Nm
M16	70 Nm
1/2"	30 Nm
5/8"	70 Nm

TX50
SI-AT-A22

The latest IFU (Instruction for Use) is available on Hilti Online. Please check for any revisions before installing the product.

MT-CTR GL OC

233483-07.2020

Set

- 2x MT-CTR GL OC Set
- 2x Nut
- 2x Washer

Extra

- 4x MT-TFB
- 2x M12 / M16 / 1/2" / 5/8"
- 1x MT-80 / MT-90 / MT-100

1 0mm

2

3 > 0mm

4 > 0mm

5 < 10 mm

6 MT-TFB

M12	30 Nm
M16	70 Nm
1/2"	30 Nm
5/8"	70 Nm

TX50
SI-AT-A22

The latest IFU (Instruction for Use) is available on Hilti Online. Please check for any revisions before installing the product.

MT Box Profiles Connectors

Pipe Stanchion - Outdoor

4

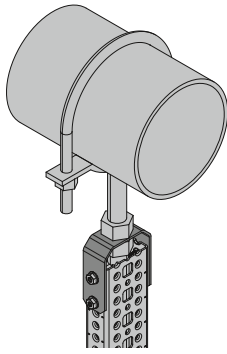

Applications

- Fastening single pipe saddles to the top of a vertical Box Profile
- Suitable for outdoor environments with low to moderate pollution (C3)

Advantages

- Part of the Hilti MT system – an economical, all-in-one solution for virtually all modular MEP support structures
- Simpler installation – full vertical adjustability from the end of the vertical Box Profile
- Easier to transport – lower weight compared to previous versions

Technical Data

Material composition	Q355 or better steel
Surface finish	Hot-dip galvanized - for outdoor use

MT-C-PS 5/8 / 7/8 / 1-1/4 OC Pipe Stanchion - Outdoor

Order Designation	Technical Data	Sales pack Quantity	Item number	
MT-C-PS 5/8 OC	Outdoor, low to moderate pollution (C3 / C4 - low)	10 pc	2343196	
MT-C-PS 7/8 OC		10 pc	2343197	
MT-C-PS 1-1/4 OC		10 pc	2343198	

MT Box Profiles Connectors

Pipe Stanchion - Outdoor

4

Technical Data Pipe Stanchion

Item image	Load drawing	Order Designation	+ Fz	- Fz	± Fy
		MT-C-PS 5/8 OC	-	5,6 kN	1,5 kN
		MT-C-PS 7/8 1 OC	-	5,6 kN	1,5 kN
		MT-C-PS 1-1/4 OC	-	5,6 kN	1,5 kN

Design notes

- Shown load values are recommended values with partial safety factors for actions and resistance included
- Design value = 1.5 * recommended value
- The design resistance of the products is defined in accordance with EN1993

Operation Instruction

MT-C-PS 5/8 OC / MT-C-PS 7/8 OC / MT-C-PS 1-1/4 OC

2347906-10.2021

The latest IFU (Instruction for Use) is available on Hilti Online. Please check for any revisions before installing the product.

5. MT Base Material Connectors

5

MT Open C-Channel Base Material Connectors 90° Connectors

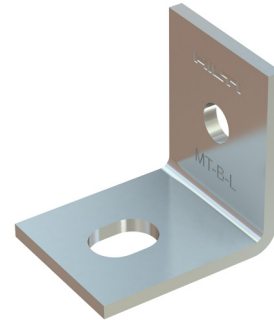

Applications

- Fastening MT C-Channel to concrete floors, walls or ceilings
- Fastening MT C-Channel to structural steel
- Anchoring metal framing and MEP support structures with extra-light loads to a Base Material

Advantages

- Part of the Hilti MT system – an economical, all-in-one solution for virtually all modular MEP support structures
- Easy to install – compatible with the Hilti MT Twist-Lock, a faster alternative to spring nuts for assembling a modular support system
- Adjustable – slotted anchor hole to simplify baseplate positioning and fastening

Technical Data

Material composition	Q235 or better steel
Surface finish	Pre-galvanized - for dry indoor use only

MT-B-L Base Material Connector 1-hole

Order Designation	Technical Data	Sales pack quantity	Item number	
MT-B-L	Dry indoor conditions (C1) Indoor with temporary condensation (C2)	20 pc	2272086	

MT-B-T Base Material Connector 2-hole

Order Designation	Technical Data	Sales pack quantity	Item number	
MT-B-T	Dry indoor conditions (C1) Indoor with temporary condensation (C2)	20 pc	2272090	

MT Open C-Channel Base Material Connectors 90° Connectors

5

MT-B-O2 Base Material Connector - 2 hole

Order Designation	Length	Thickness	Weight	Technical Data	Sals pack quantity	Item number	
MT-B-O2	185 mm	4 mm	1027 g	Dry indoor conditions (C1) Indoor with temporary condensation (C2)	12 pc	2272094	

MT-B-O2B Base Material Connector - 2 hole

Order Designation	Length	Thickness	Weight	Technical Data	Sals pack quantity	Item number	
MT-B-O2B	200 mm	8 mm	2072 g	Dry indoor conditions (C1) Indoor with temporary condensation (C2)	6 pc	2282212	

MT-B-O2B 60D Base Material Connector - double Channel

Order Designation	Length	Thickness	Weight	Technical Data	Sals pack quantity	Item number	
MT-B-O2B 60D	270 mm	8 mm	2572 g	Dry indoor conditions (C1) Indoor with temporary condensation (C2)	6 pc	2358236	

MT-B-O4 Base Material Connector - 4 hole

Order Designation	Length	Thickness	Weight	Technical Data	Sals pack quantity	Item number	
MT-B-O4	200 mm	8 mm	3315 g	Dry indoor conditions (C1) Indoor with temporary condensation (C2)	4 pc	2272098	

MT Open C-Channel Base Material Connectors

90° Connectors - Outdoor

5

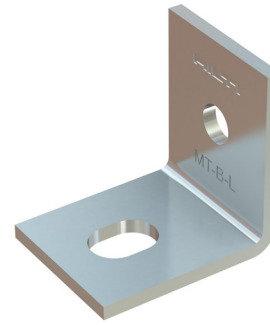
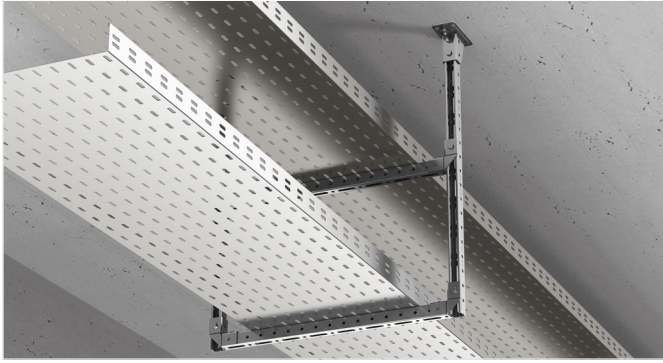

Applications

- Fastening MT C-Channel to concrete floors, walls or ceilings
- Fastening MT C-Channel to structural steel
- Anchoring metal framing and MEP support structures with extra-light loads to a Base Material

Advantages

- Part of the Hilti MT system – an economical, all-in-one solution for virtually all modular MEP support structures
- Easy to install – compatible with the Hilti MT Twist-Lock, a faster alternative to spring nuts for assembling a modular support system
- Adjustable – slotted anchor hole to simplify baseplate positioning and fastening

Technical Data

Material composition	Q235 or better steel
Surface finish	Hot-dip galvanized - for outdoor use

MT-B-L OC Base Material Connector - 1-hole - Outdoor

Order Designation	Length	Thickness	Weight	Technical Data	Sals pack quantity	Item number	
MT-B-L OC	52 mm	4 mm	119 g	Outdoor, low to moderate pollution (C3 / C4 - low)	20 pc	2272088	

MT-B-T OC Base Material Connector - 2-hole - Outdoor

Order Designation	Length	Thickness	Weight	Technical Data	Sals pack quantity	Item number	
MT-B-T OC	112 mm	2 mm	569 g	Outdoor, low to moderate pollution (C3 / C4 - low)	20 pc	2272092	

MT Open C-Channel Base Material Connectors

90° Connectors - Outdoor

5

MT-B-02 OC Base Material Connector - 2-hole - Outdoor

Order Designation	Length	Thickness	Weight	Technical Data	Sals pack quantity	Item number	
MT-B-02 OC	185 mm	4 mm	1031 g	Outdoor, low to moderate pollution (C3 / C4 - low)	12 pc	2272096	

MT-B-02B OC Base Material Connector - 2-hole - Outdoor

Order Designation	Length	Thickness	Weight	Technical Data	Sals pack quantity	Item number	
MT-B-02B OC	200 mm	8 mm	2072 g	Outdoor, low to moderate pollution (C3 / C4 - low)	6 pc	2282213	

MT-B-02B 60D OC Base Material Connector - double Channel - Outdoor

Order Designation	Length	Thickness	Weight	Technical Data	Sals pack quantity	Item number	
MT-B-02B 60D OC	270 mm	8 mm	2572 g	Outdoor, low to moderate pollution (C3 / C4 - low)	6 pc	2358237	

MT-B-04 OC Base Material Connector - 4-hole - Outdoor

Order Designation	Length	Thickness	Weight	Technical Data	Sals pack quantity	Item number	
MT-B-04 OC	200 mm	8 mm	3315 g	Outdoor, low to moderate pollution (C3 / C4 - low)	4 pc	2272099	

MT Fast-Lock Baseplates

with pre-assembled Fast-Lock nut and bolt for anchoring light-duty C-Channel structures to concrete or steel

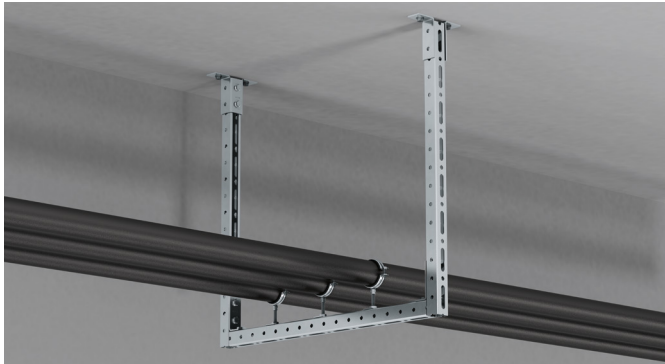

Applications

- Fastening MT C-Channel to concrete floors, walls or ceilings
- Fastening MT C-Channel to structural steel
- Anchoring metal framing and MEP support structures with medium loads to a Base Material
- Suitable for use in dry, indoor environments

Advantages

- Faster installations – pre-assembled with the Hilti MT Fast-Lock, our fastest method for assembling a modular support system with fewer steps
- Simplified stock management – pre-assembly greatly reduces the total number of MT components, for easier purchasing, handling, and storage
- Consistent installation quality – pre-assembly removes additional steps, helping reduce assembly errors for safer installations
- Adjustable – slotted anchor hole to simplify baseplate positioning and fastening
- Part of the Hilti MT system – an economical, all-in-one solution for virtually all modular MEP support structures
- Extensive software support - PROFIS Modular Support Engineering, BIMCAD content, and Revit® families are all available to streamline design and ordering

Technical Data

Material composition	DD11 MOD
Surface finish	Indoor-coated Electro-galvanized

MT-B-T FL Pre-assembled Base plate

Order Designation	Material composition	Technical Data	Sales pack quantity	Item number	
MT-B-T FL	S235JR, Q235B	Dry indoor conditions (C1) Indoor with temporary condensation (C2)	16 pc	2399639	

MT-B-O2 FL Pre-assembled Base plate

Order Designation	Material composition	Technical Data	Sales pack quantity	Item number	
MT-B-O2 FL	S235JR, Q235B	Dry indoor conditions (C1) Indoor with temporary condensation (C2)	16 pc	2399660	

MT-B-L FL Pre-assembled Base plate

Order Designation	Material composition	Technical Data	Sales pack quantity	Item number	
MT-B-L FL	S235JR, Q235B	Dry indoor conditions (C1) Indoor with temporary condensation (C2)	18 pc	2399665	

MT Fast-Lock Baseplates - Outdoors

Base Connector with pre-assembled Fast-Lock nut and bolt for anchoring light-duty C-Channel structures to concrete or steel, for outdoor use with low pollution

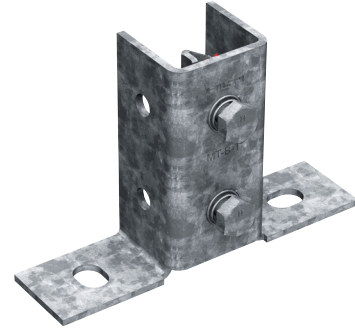

Applications

- Fastening MT C-Channel to concrete floors, walls or ceilings
- Fastening MT C-Channel to structural steel
- Anchoring metal framing and MEP support structures with medium loads to a Base Material
- Suitable for use in moderately corrosive environments

Technical Data

Material composition	DD11 MOD
Surface finish	Hot Dip Galvanized

Advantages

- Faster installations – pre-assembled with the Hilti MT Fast-Lock, our fastest method for assembling a modular support system with fewer steps
- Simplified stock management – pre-assembly greatly reduces the total number of MT components, for easier purchasing, handling, and storage
- Consistent installation quality – pre-assembly removes additional steps, helping reduce assembly errors for safer installations
- Adjustable – slotted anchor hole to simplify baseplate positioning and fastening
- Part of the Hilti MT system – an economical, all-in-one solution for virtually all modular MEP support structures
- Extensive software support - PROFIS Modular Support Engineering, BIMCAD content, and Revit® families are all available to streamline design and ordering

MT-B-T FL OC Pre-assembled Base plate - Outdoors

Order Designation	Material composition	Technical Data	Sales pack quantity	Item number	
MT-B-T FL OC	S235JR, Q235B	Outdoor, low to moderate pollution (C3 / C4 - low)	16 pc	2399674	

MT-B-O2 FL OC Pre-assembled Base plate - Outdoors

Order Designation	Material composition	Technical Data	Sales pack quantity	Item number	
MT-B-O2 FL OC	S235JR, Q235B	Outdoor, low to moderate pollution (C3 / C4 - low)	16 pc	2399675	

MT-B-L FL OC Pre-assembled Base plate - Outdoors

Order Designation	Material composition	Technical Data	Sales pack quantity	Item number	
MT-B-L FL OC	S235JR, Q235B	Outdoor, low to moderate pollution (C3 / C4 - low)	18 pc	2399677	

MT Open C-Channel Base Material Connectors

90° Connectors

5

Technical Data Base Material Connectors

Item image	Load drawing	Order Designation	+ Fz	- Fz	± Fx	± Fy
		MT-B-L / MT-B-L OC	5,0 kN	2,1 kN	2,1 kN	0,0 kN
		MT-B-T / MT-B-T OC	0,6 kN	0,6 kN	6,0 kN	1,2 kN
		MT-B-O2 / MT-B-O2 OC	5,2 kN	5,2 kN	9,0 kN	1,7 kN
		MT-B-O2B / MT-B-O2B OC	19,2 kN	19,2 kN	12,6 kN	3,6 kN
		MT-B-O4B / MT-B-O4B OC	19,2 kN	19,2 kN	12,6 kN	3,6 kN
		MT-B-T FL / MT-B-T FL OC	0,6 kN	0,6 kN	6,0 kN	1,2 kN
		MT-B-O2 FL / MT-B-O2 FL OC	5,2 kN	5,2 kN	9,0 kN	1,7 kN
		MT-B-L FL / MT-B-L FL OC	5,0 kN	2,1 kN	2,1 kN	0,0 kN

Design notes

- Shown load values are recommended values with partial safety factors for actions and resistance included
- Design value = 1.4 * recommended value
- The design resistance of the products is defined in accordance with EN1993

MT Open C-Channel Base Material Connectors

90° Connectors

Operation Instruction

MT-B-L / MT-B-L OC

2288351-04.2020

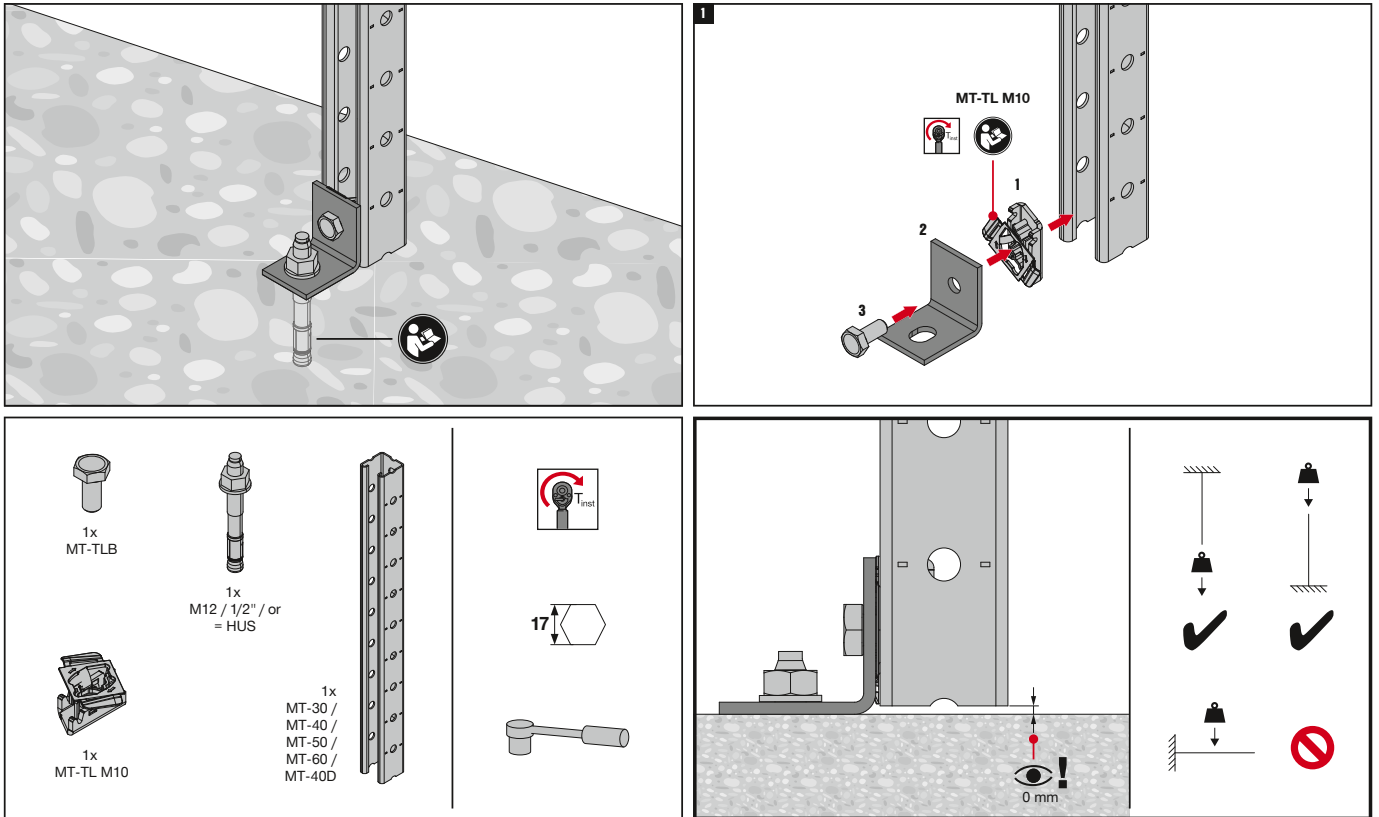

The latest IFU (Instruction for Use) is available on Hilti Online. Please check for any revisions before installing the product.

MT-B-T / MT-B-T OC

2288352-06.2020

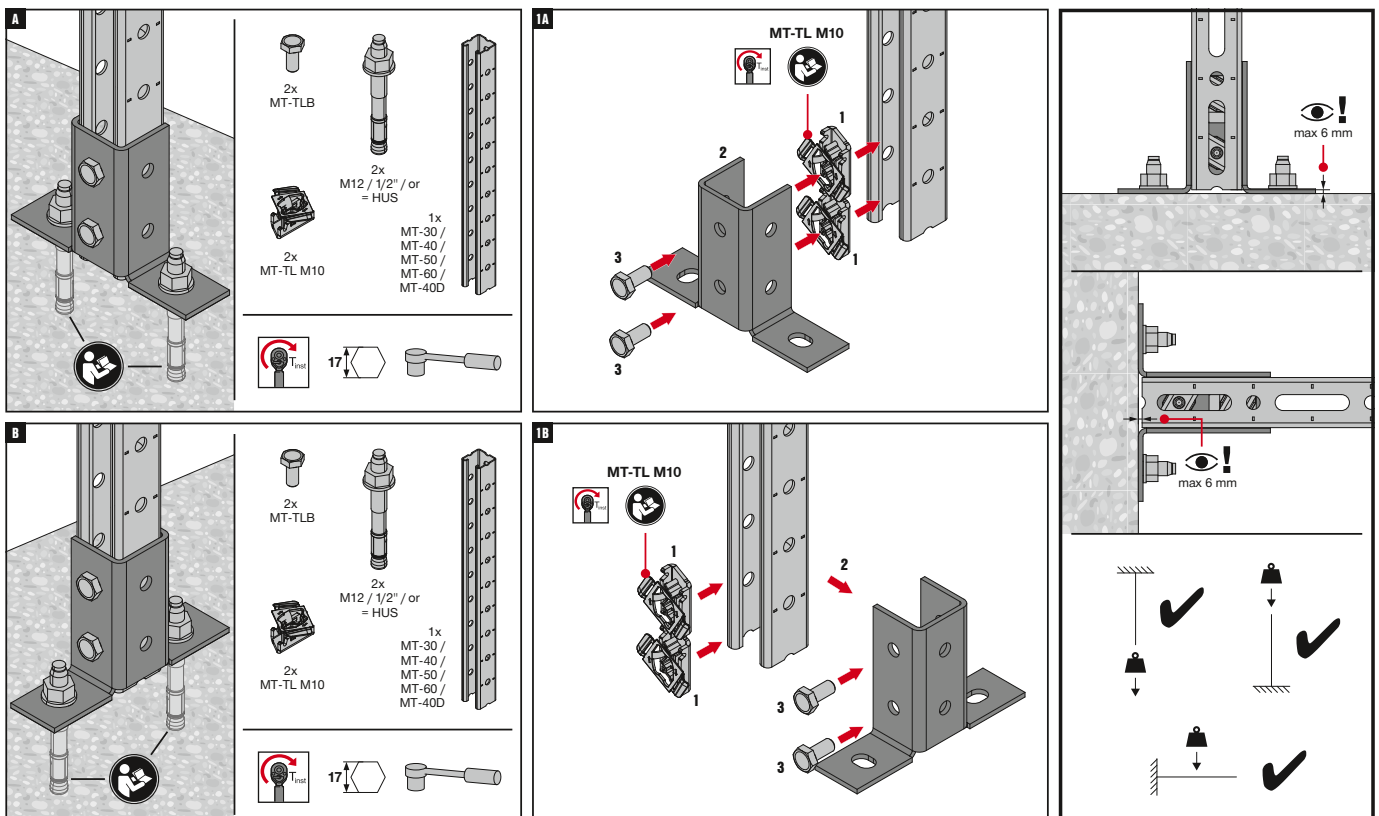

The latest IFU (Instruction for Use) is available on Hilti Online. Please check for any revisions before installing the product.

MT Open C-Channel Base Material Connectors

90° Connectors

Operation Instruction

MT-B-02 / MT-B-02 OC

2288353-09.2020

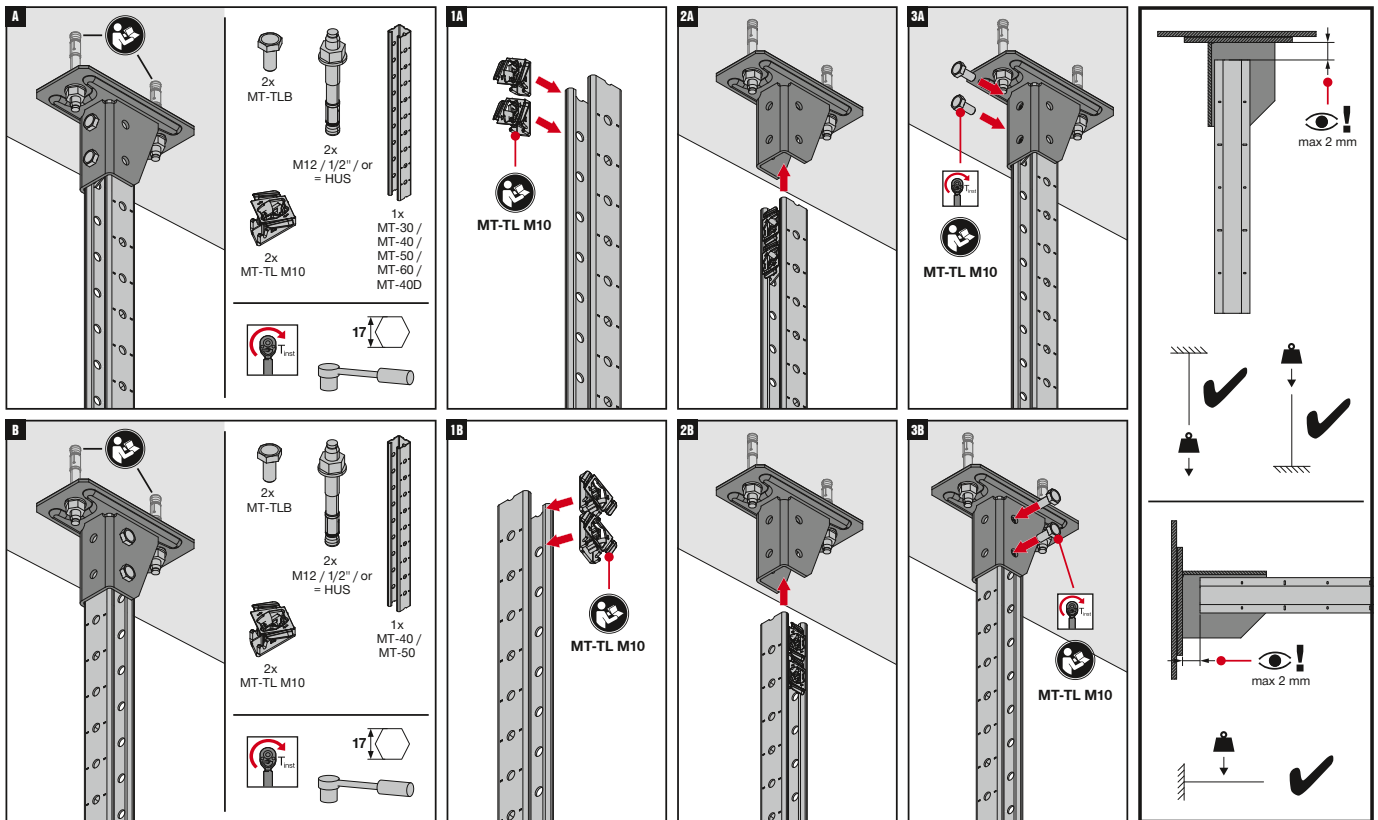

The latest IFU (Instruction for Use) is available on Hilti Online. Please check for any revisions before installing the product.

MT-B-02B / MT-B-02B OC

2288354-09.2020

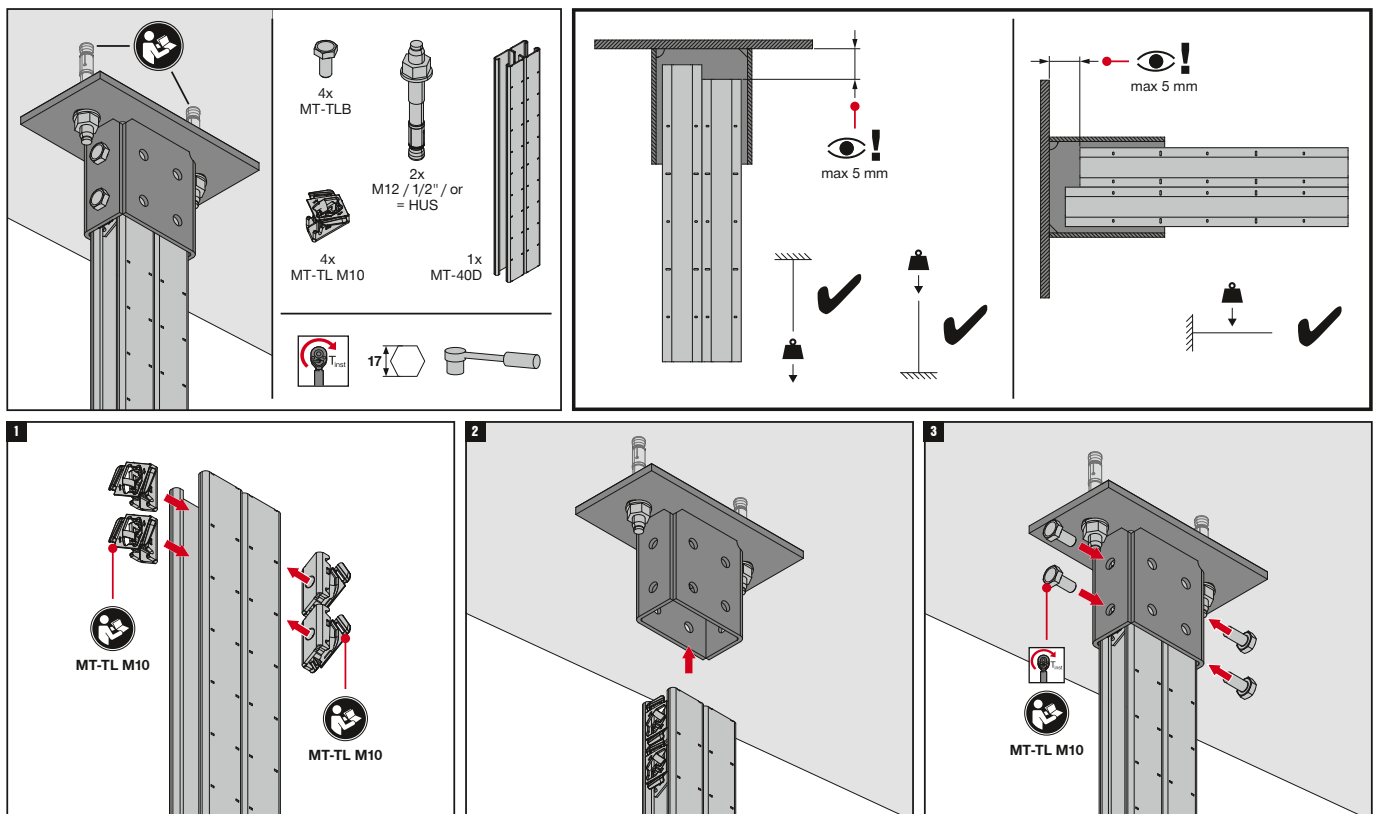

The latest IFU (Instruction for Use) is available on Hilti Online. Please check for any revisions before installing the product.

MT Open C-Channel Base Material Connectors

90° Connectors

5

Operation Instruction

MT-B-04 / MT-B-04 OC

2288355-09.2020

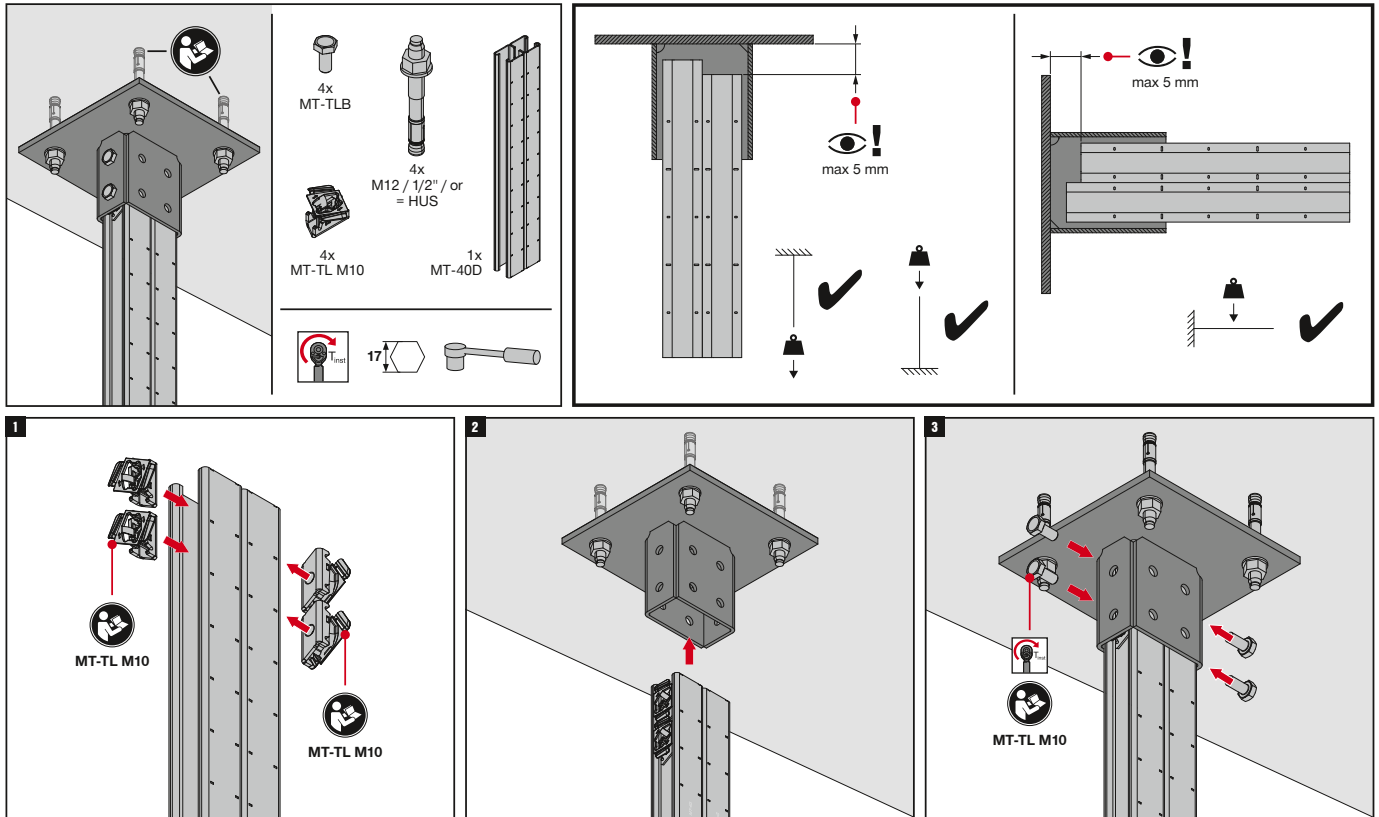

The latest IFU (Instruction for Use) is available on Hilti Online. Please check for any revisions before installing the product.

MT Open C-Channel Base Material Connectors Angle Brace

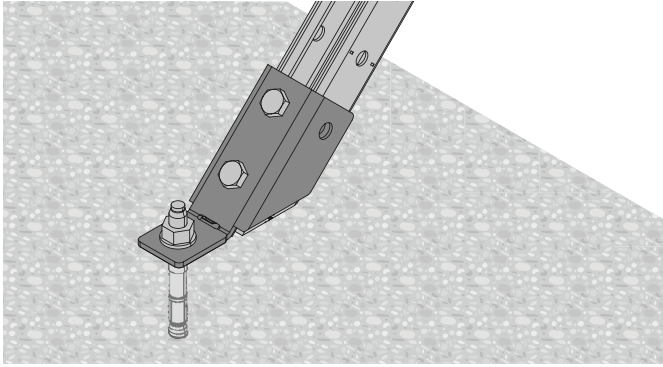

Applications

- Anchoring MT-40 or MT-50 C-Channels to concrete at a 45-degree angle for use as lateral bracing
- Lateral bracing of lightweight metal framing and MEP support structures
- Suitable for use in dry, indoor environments

Advantages

- Part of the Hilti MT system – an economical, all-in-one solution for virtually all modular MEP support structures
- Easy to install – compatible with the Hilti MT Twist-Lock, a faster alternative to spring nuts for assembling a modular support system
- Part of a complete Hilti solution – compatible with our direct fastening and anchoring solutions

Technical Data

Material composition	Q235 or better steel
Surface finish	Pre-galvanized - for dry indoor use only

MT-AB-L 45 Angle Brace

Order Designation	Thickness	Weight	Technical Data	Sales pack quantity	Item number	
MT-AB-L 45	4 mm	427 g	Dry indoor conditions (C1) Indoor with temporary condensation (C2)	10 pc	2272113	

MT-AB-LL2 45 Angle Brace

Order Designation	Thickness	Weight	Technical Data	Sales pack quantity	Item number	
MT-AB-LL2 45	4 mm	553 g	Dry indoor conditions (C1) Indoor with temporary condensation (C2)	10 pc	2272115	

MT-AB set Angle Brace adjustable

Order Designation	Thickness	Weight	Technical Data	Sales pack quantity	Item number	
MT-AB A set	4 mm	441 g	Dry indoor conditions (C1) Indoor with temporary condensation (C2)	12 pc	2346395	

MT Open C-Channel Base Material Connectors

Channel Clamp

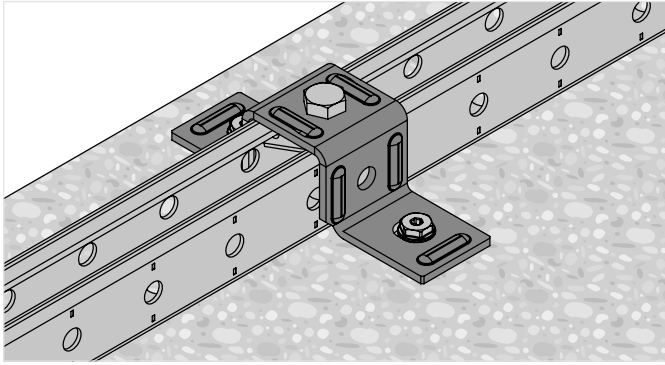

Applications

- Cross-connection of one C-Channel to concrete
- Suitable for use in dry, indoor environments

Technical Data

Material composition	Q235 or better steel
Surface finish	Indoor Coated - Electro galvanized

Advantages

- Compatible with MT Twist-Lock and MT Thread forming Bolt Channel Connectors – for much faster, adaptable assembly
- Universal – complete many different Applications using few parts
- Twist-lock and Thread forming Bolt Channel Connector takes up shear and tensile loads

MT-CC-BC 40/50 Base Material Connector - Channel Clamp

Order Designation	Thickness	Weight	Technical Data	Sales pack quantity	Item number	
MT-CC-BC 40/50	4 mm	326 g	Dry indoor conditions (C1) Indoor with temporary condensation (C2)	20 pc	2322432	

MT-CC-BS 40/50 Base Material Connector - Channel Clamp

Order Designation	Thickness	Weight	Technical Data	Sales pack quantity	Item number	
MT-CC-BS 40/50	4 mm	326 g	Dry indoor conditions (C1) Indoor with temporary condensation (C2)	20 pc	2322402	

MT Open C-Channel Base Material Connectors

Angle Brace - Outdoor

5

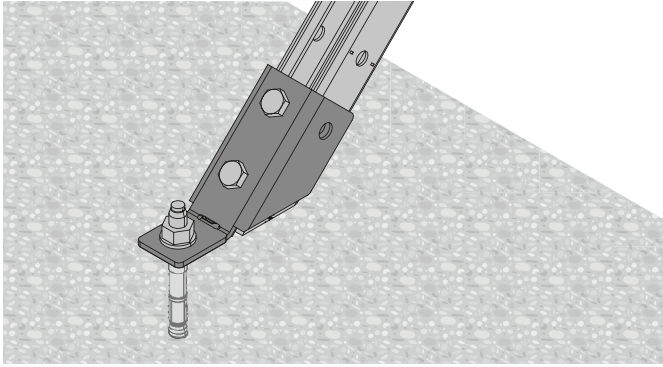

Applications

- Anchoring MT-40 or MT-50 C-Channels to concrete at a 45-degree angle for use as lateral bracing
- Lateral bracing of lightweight metal framing and MEP support structures
- Suitable for use in moderately corrosive environments

Advantages

- Part of the Hilti MT system – an economical, all-in-one solution for virtually all modular MEP support structures
- Easy to install – compatible with the Hilti MT Twist-Lock, a faster alternative to spring nuts for assembling a modular support system
- Part of a complete Hilti solution – compatible with our direct fastening and anchoring solutions

Technical Data

Material composition	Q235 or better steel
Surface finish	Outdoor Coated - HDG

MT-AB-L 45 OC Angle Brace - Outdoor

Order Designation	Thickness	Weight	Technical Data	Sales pack quantity	Item number	
MT-AB-L 45 OC	4 mm	427 g	Outdoor, low to moderate pollution (C3 / C4 - low)	10 pc	2272114	

MT-AB-LL2 45 OC Angle Brace - Outdoor

Order Designation	Thickness	Weight	Technical Data	Sales pack quantity	Item number	
MT-AB-LL2 45 OC	4 mm	553 g	Outdoor, low to moderate pollution (C3 / C4 - low)	10 pc	2273585	

MT-AB A OC Angle Brace Adjustable - Outdoor

Order Designation	Thickness	Weight	Technical Data	Sales pack quantity	Item number	
MT-AB A OC set	4 mm	44 g	Outdoor, low to moderate pollution (C3 / C4 - low)	12 pc	2346396	

MT Open C-Channel Base Material Connectors

Channel Clamp - Outdoor

5

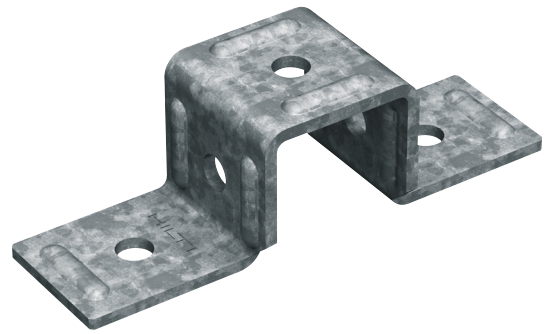
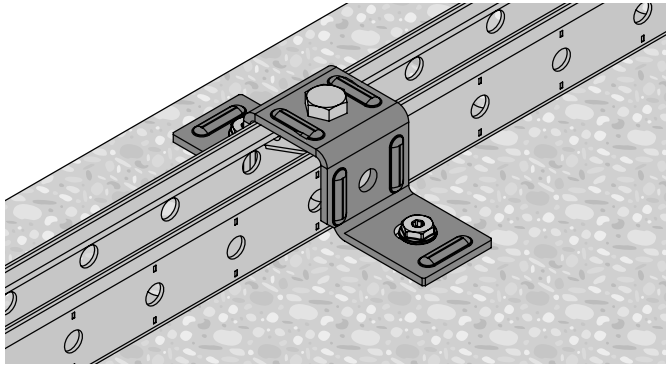

Applications

- Cross-connection of one C-girder to another Channel or girder
- Suitable for use in moderately corrosive environments

Technical Data

Material composition	Q235 or better steel
Surface finish	Outdoor Coated - HDG

Advantages

- Compatible with MT Twist-Lock and MT Thread forming Bolt Channel Connectors – for much faster, adaptable assembly
- Universal – complete many different Applications using few parts
- Twist-lock and Thread forming Bolt Channel Connector takes up shear and tensile loads

MT-CC-BC 40/50 OC Base Material Connector - Channel Clamp - Outdoor

Order Designation	Thickness	Weight	Technical Data	Sales pack quantity	Item number	
MT-CC-BC 40/50 OC	4 mm	326 g	Outdoor, low to moderate pollution (C3 / C4 - low)	20 pc	2322401	

MT-CC-BS 40/50 OC Base Material Connector - Channel Clamp - Outdoor

Order Designation	Thickness	Weight	Technical Data	Sales pack quantity	Item number	
MT-CC-BS 40/50 OC	4 mm	326 g	Outdoor, low to moderate pollution (C3 / C4 - low)	20 pc	2322403	

MT Open C-Channel Base Material Connectors

Channel Clamp - Outdoor

5

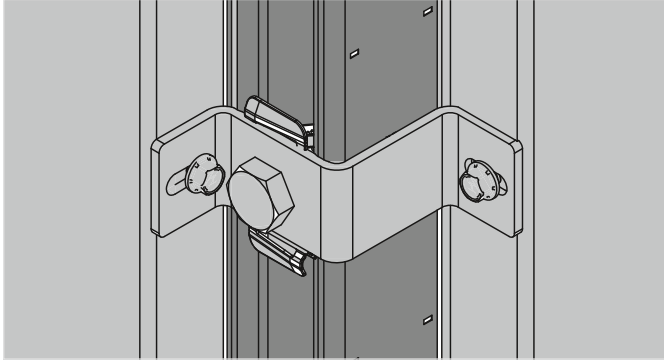

Applications

- Attaching polypanels to a substructure of MT strut/Box Profile
- Hot/cold aisle containment in data centers

Advantages

- Helps lower installation cost – this new solution uses fewer and simpler components than previous Hilti panel Connectors, saving you upfront costs and time on-site
- Compatible with MT Thread forming Bolt Channel Connectors – for much faster, adaptable assembly with higher pull-out and shear resistance
- Corrosion resistance – hot-dip galvanized to help protect against moisture and chemical corrosion

Technical Data

Material composition	Q235 or better steel
Surface finish	Outdoor Coated - HDG

MT-CC-40/50 C OC Channel Clamp - Outdoor

Order Designation	Height	Technical Data	Sales pack quantity	Item number	
MT-CC-40/50 C OC	3 mm	Outdoor, low to moderate pollution (C3 / C4 - low)	8 pc	2353779	

MT-CC-40/50 M OC Channel Clamp - Outdoor

Order Designation	Height	Technical Data	Sales pack quantity	Item number	
MT-CC-40/50 M OC	3 mm	Outdoor, low to moderate pollution (C3 / C4 - low)	16 pc	2353800	

MT Open C-Channel Base Material Connectors

Angle Brace, Channel Clamp

5

Technical Data Angle Brace

Item image	Load drawing	Order Designation	+ Fz	- Fz	± Fx	± Fy
		MT-AB A / MT-AB A OC	-	-	9,9 kN	-
		MT-AB-L 45 / MT-AB-L 45 OC	-	-	3,8 kN	-

Design notes

- Shown load values are recommended values with partial safety factors for actions and resistance included
- Design value = 1.4 * recommended value
- The design resistance of the products is defined in accordance with EN1993

Technical Data Channel Clamp

Item image	Load drawing	Order Designation	+ Fx	- Fx	+ Fy	- Fy	+ Fz	- Fz
		MT-CC-40/50 / MT-CC-40/50 OC	2,50 kN	2,50 kN	5,71 kN	5,71 kN	--	5,36 kN

Design notes

- Shown load values are recommended values with partial safety factors for actions and resistance included
- Design value = 1.4 * recommended value
- The design resistance of the products is defined in accordance with EN1993

MT Open C-Channel Base Material Connectors

Angle Brace

Operation Instruction

MT-AB-L 45 / MT-AB-L 45 OC

2294695-07.2020

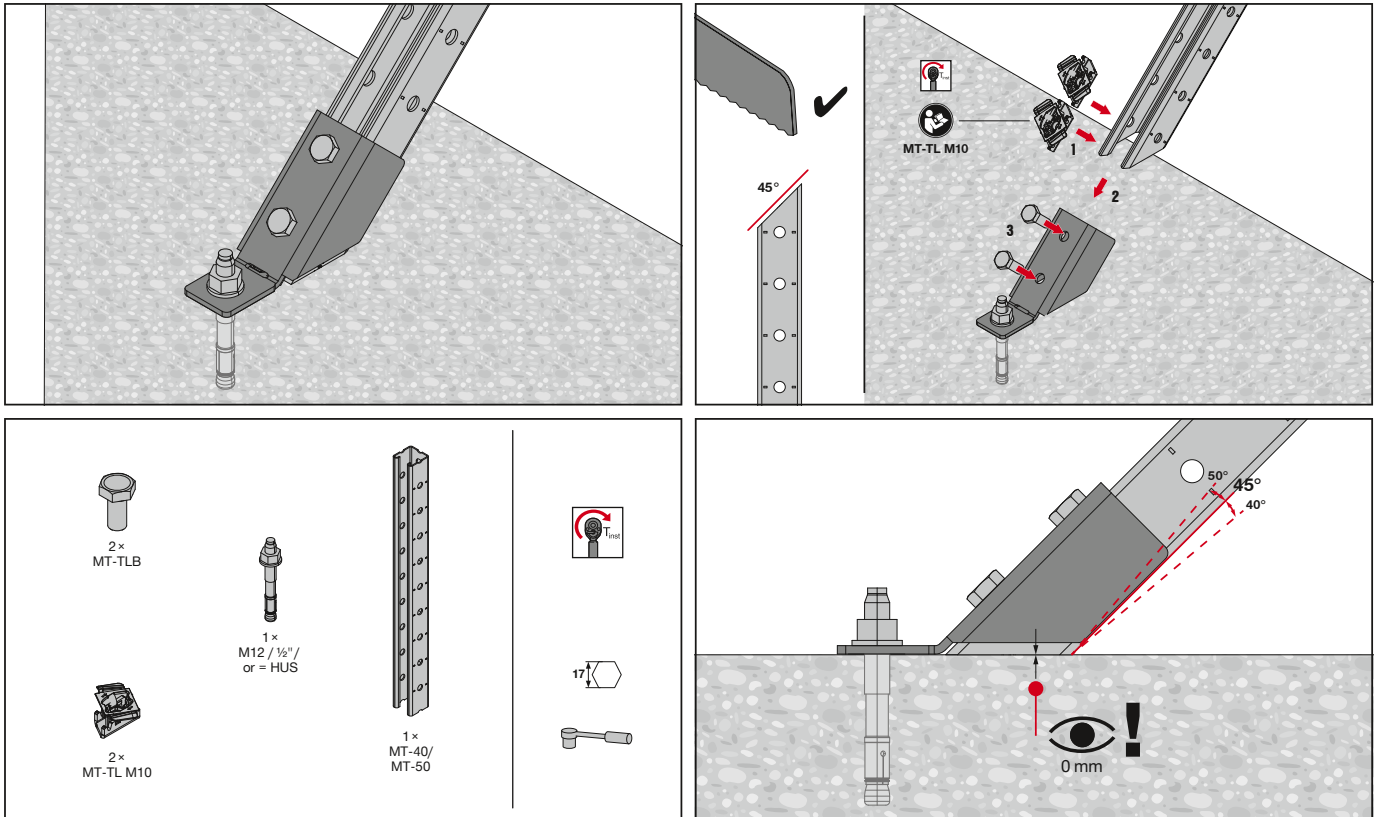

The latest IFU (Instruction for Use) is available on Hilti Online. Please check for any revisions before installing the product.

MT-AB-LL2 45 / MT-AB-LL2 45 OC

2294696-07.2020

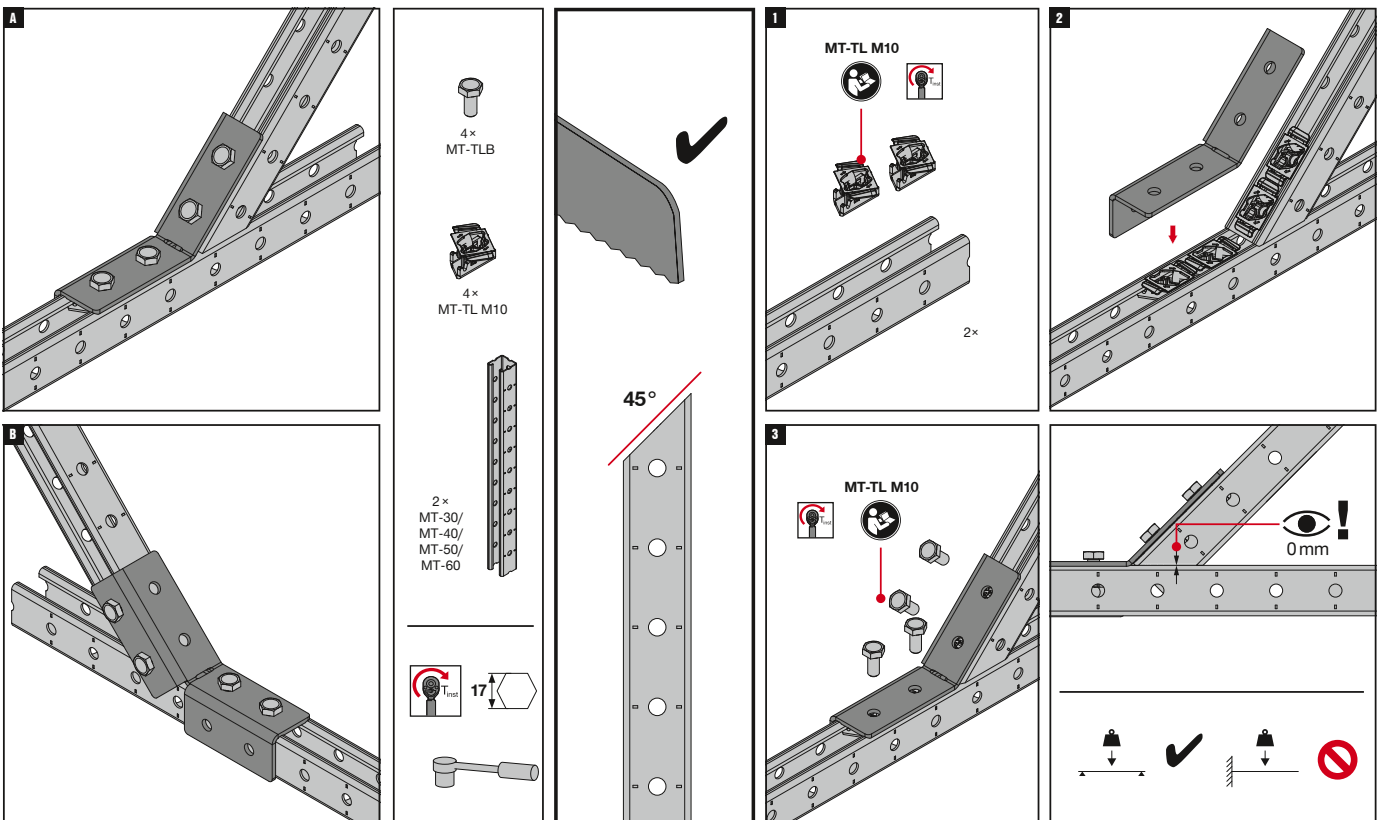

The latest IFU (Instruction for Use) is available on Hilti Online. Please check for any revisions before installing the product.

MT Open C-Channel Base Material Connectors

Angle Brace, Channel Clamp

Operation Instruction MT-AB-A / MT-AB-A OC

2294694-07.2020

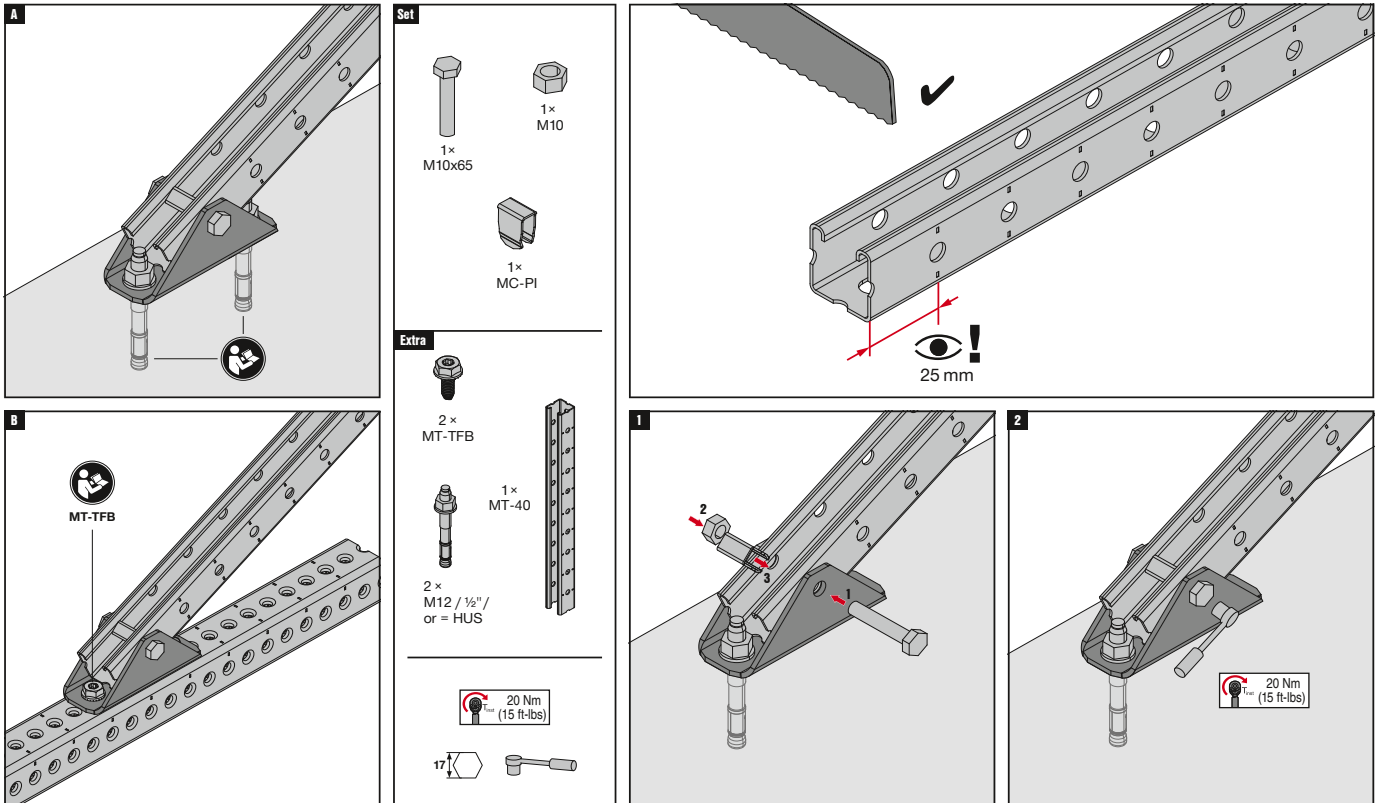

The latest IFU (Instruction for Use) is available on Hilti Online. Please check for any revisions before installing the product.

Operation Instruction

MT-CC-BC 40/50 / MT-CC-BS 40/50 / MT-CC-BC 40/50 OC / MT-CC-BS 40/50 OC

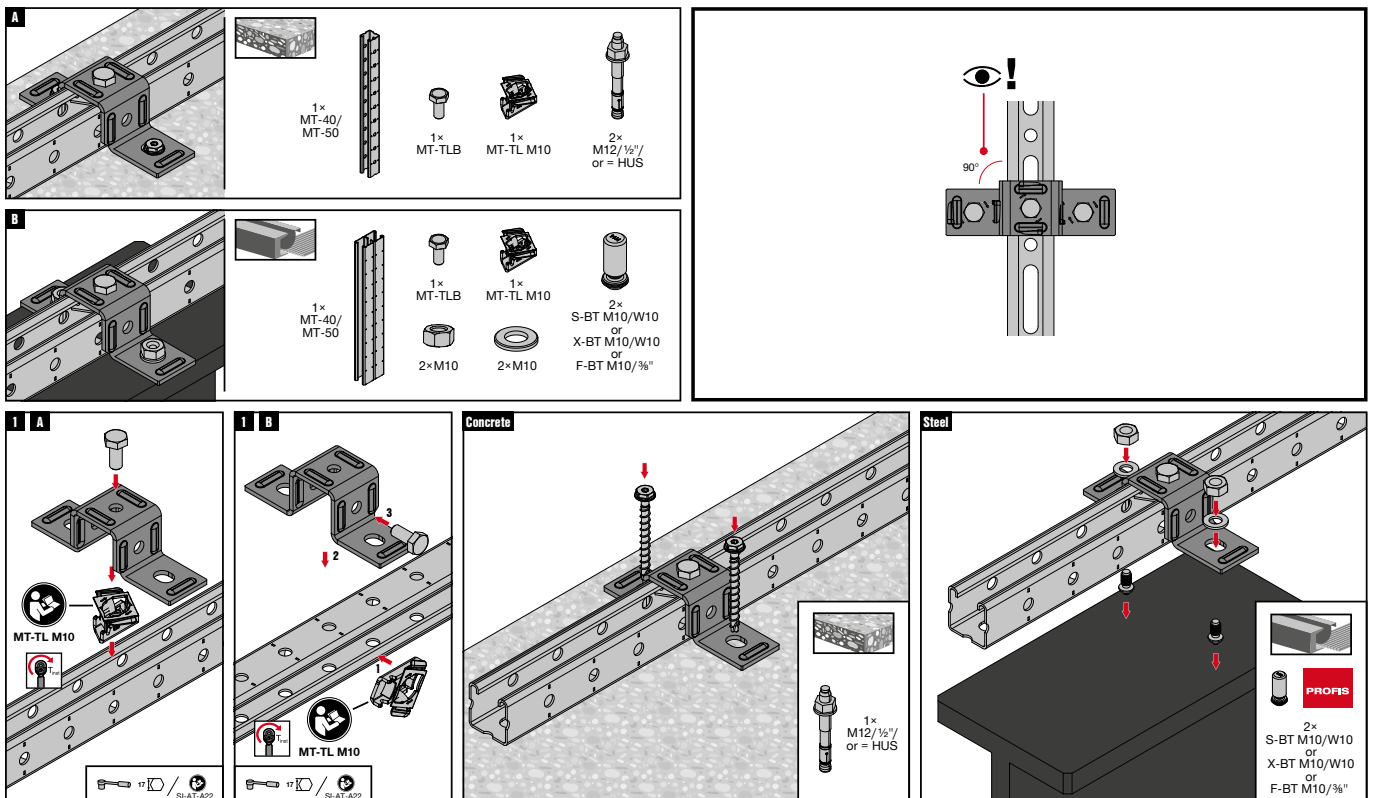

The latest IFU (Instruction for Use) is available on Hilti Online. Please check for any revisions before installing the product.

MT Open C-Channel Base Material Connectors

Channel Clamp

Operation Instruction

MT-CC-40/50 C OC

2359994-04.2022

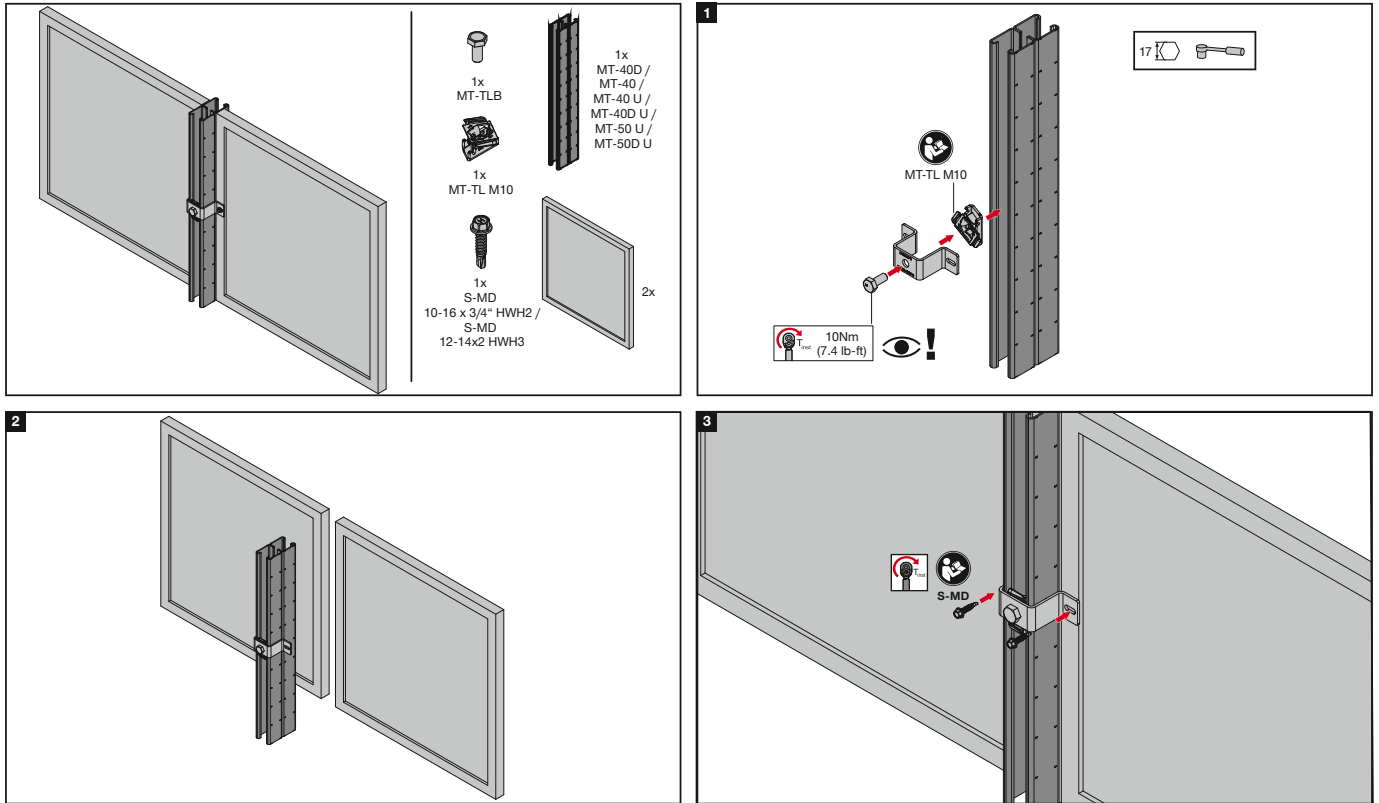

The latest IFU (Instruction for Use) is available on Hilti Online. Please check for any revisions before installing the product.

MT-CC-40/50 M OC

2359995-04.2022

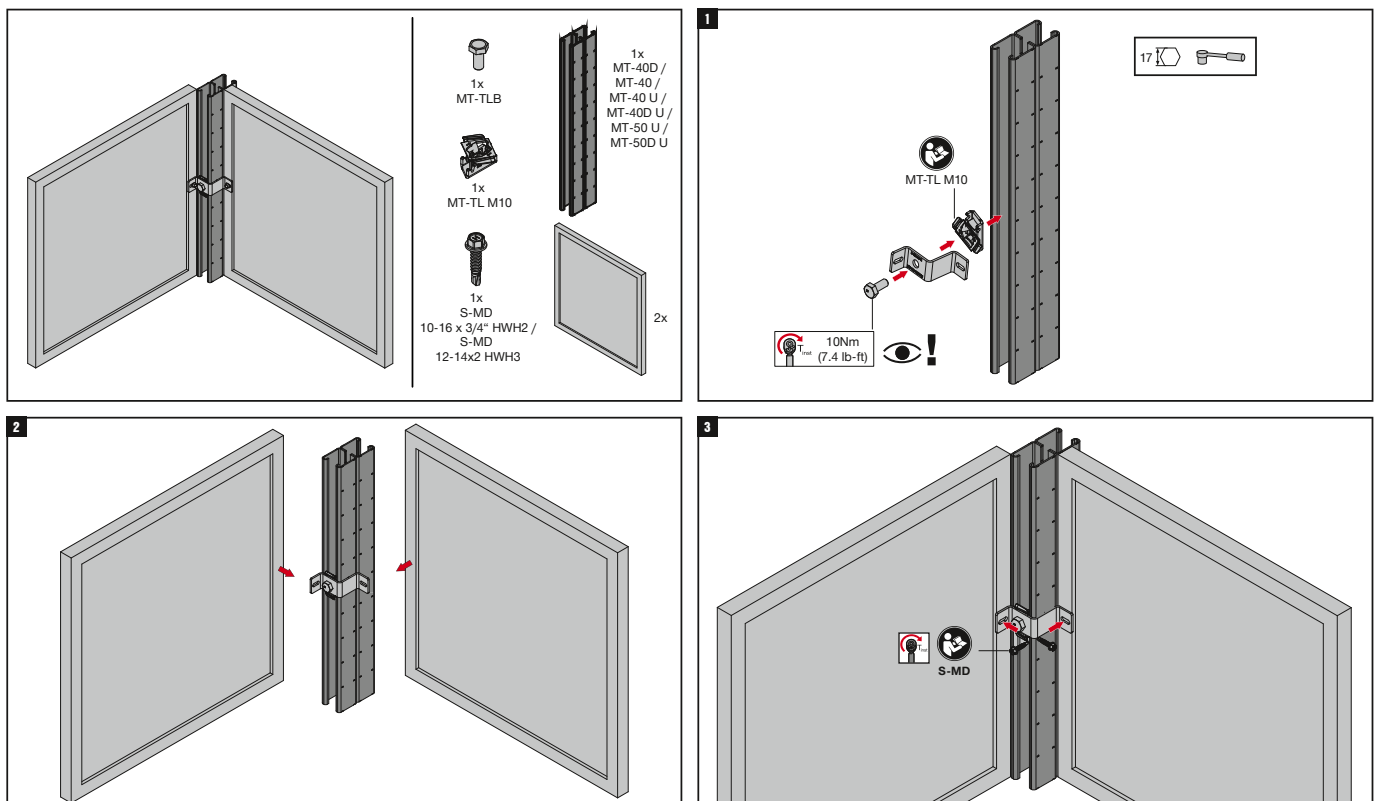

The latest IFU (Instruction for Use) is available on Hilti Online. Please check for any revisions before installing the product.

MT Box Profiles Baseplates

90° Connectors - Outdoor

5

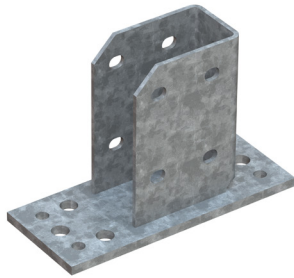

Applications

- Fastening MT-70 and MT-80 Box Profiles to concrete floors, walls or ceilings
- Fastening MT-70 and MT-80 Box Profiles to structural steel
- Anchoring metal framing and MEP support structures with light loads to a Base Material

Advantages

- Part of the Hilti MT system – an economical, all-in-one solution for virtually all modular MEP support structures
- Easy to install – one-step assembly using Hilti MT-TFB thread-forming bolts
- Adaptable – unlike welding, modular metal framing can be modified for future MEP requirements

Technical Data

Material composition	Q235 or better steel
Surface finish	Outdoor Coated - HDG

MT-B-GS T OC Base Material Connector - Outdoor

Order Designation	Weight	Technical Data	Sales pack quantity	Item number	
MT-B-GS T OC	2166 g	Outdoor, low to moderate pollution (C3 / C4 - low)	2 pc	2272100	

MT-B-GS O4U OC Base Material Connector 4-hole - Outdoor

Order Designation	Weight	Technical Data	Sales pack quantity	Item number	
MT-B-GS O4U OC	4730 g	Outdoor, low to moderate pollution (C3 / C4 - low)	4 pc	2272101	

MT Box Profiles Baseplates

90° Connectors - Outdoor

5

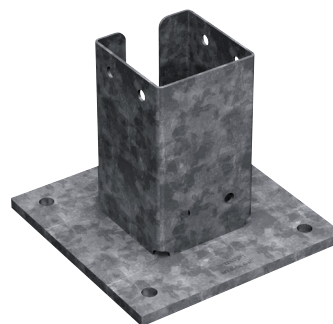
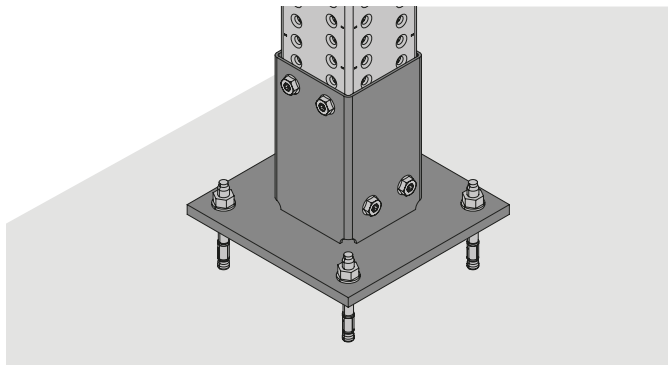

Applications

- Fastening MT-90 Box Profiles to concrete floors, walls or ceilings
- Anchoring metal framing and MEP support structures with heavy loads to a Base Material
- Suitable for outdoor environments with low to moderate pollution (C3)

Advantages

- Part of the Hilti MT system – an economical, all-in-one solution for virtually all modular MEP support structures
- Easy to install – one-step assembly using Hilti MT-TFB thread-forming bolts
- Adaptable – unlike welding, modular post bases allow you to modify metal framing for future MEP requirements

Technical Data

Material composition	Q235 or better steel
Surface finish	Outdoor Coated - HDG

MT-B-GL O4C OC Base Material Connector - Outdoor

Order Designation	Weight	Technical Data	Sales pack quantity	Item number
MT-B-GL O4C OC	6825g	Outdoor, low to moderate pollution (C3 / C4 - low)	2 pc	2343282

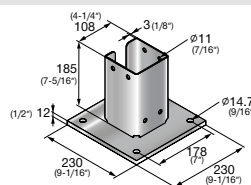

MT Box Profiles Baseplates

90° Connectors - Outdoor

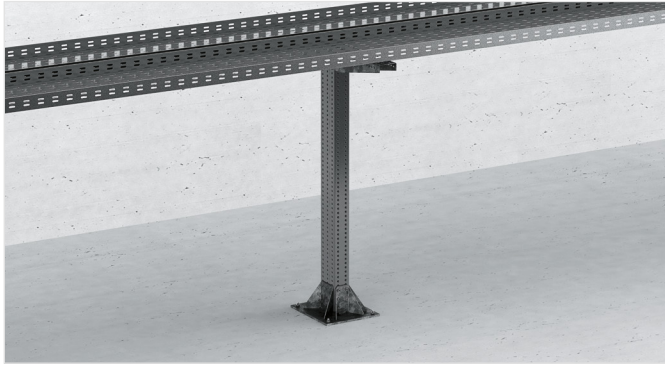

Applications

- Fastening MT-90 Box Profiles to concrete floors, walls or ceilings
- Anchoring metal framing and MEP support structures with heavy loads to a Base Material
- Suitable for use in moderately corrosive environments

Advantages

- Part of the Hilti MT system – an economical, all-in-one solution for virtually all modular MEP support structures
- Easy to install – one-step assembly using Hilti MT-TFB thread-forming bolts
- Adaptable – unlike welding, modular post bases allow you to modify metal framing for future MEP requirements

Technical Data

Material composition	Q235 or better steel
Surface finish	Outdoor Coated - HDG

MT-B-GL O4 OC Base Material Connector 4-hole - Outdoor

Order Designation	Thickness	Weight	Technical Data	Sales pack quantity	Item number	
MT-B-GL O4 OC	12 mm	14949 g	Outdoor, low to moderate pollution (C3 / C4 - low)	1 pc	2272103	

MT-B-GXL O4 OC Base Material Connector 4-hole - Outdoor

Order Designation	Thickness	Weight	Technical Data	Sales pack quantity	Item number	
MT-B-GXL O4 OC	12 mm	17070 g	Outdoor, low to moderate pollution (C3 / C4 - low)	1 pc	2272104	

MT Box Profiles Baseplates

90° Connectors - Outdoor

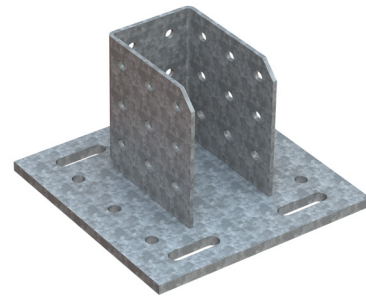
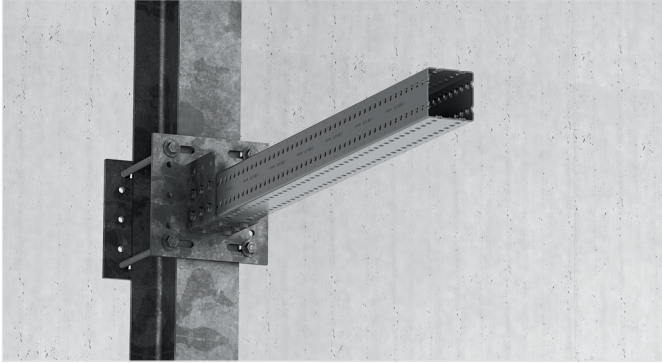

Applications

- Fastening MT-90 and MT-100 Box Profiles to structural steel
- Anchoring metal framing and MEP support structures with light loads to a Base Material
- Suitable for use in moderately corrosive environments

Advantages

- Part of the Hilti MT system – an economical, all-in-one solution for virtually all modular MEP support structures
- Easy to install – one-step assembly using Hilti MT-TFB thread-forming bolts
- Adjustable – four slotted anchor holes to simplify baseplate positioning and fastening

Technical Data

Material composition	Q355 or better steel
Surface finish	Outdoor Coated - HDG

MT-B-GXL S1 OC Base Material Connector To Steel - Outdoor

Order designation	Thickness	Weight	Technical Data	Sales pack quantity	Item number	
MT-B-GXL S1 OC	15 mm	9402 g	Outdoor, low to moderate pollution (C3 / C4 - low)	2 pc	2272106	

MT-B-GXL S2 OC Base Material Connector To Steel - Outdoor

Order designation	Thickness	Weight	Technical Data	Sales pack quantity	Item number	
MT-B-GXL S2 OC	15 mm	9366 g	Outdoor, low to moderate pollution (C3 / C4 - low)	2 pc	2272107	

MT-B-GXL S3 OC Base Material Connector To Steel - Outdoor

Order designation	Thickness	Weight	Technical Data	Sales pack quantity	Item number	
MT-B-GXL S3 OC	15 mm	10816 g	Outdoor, low to moderate pollution (C3 / C4 - low)	2 pc	2272108	

MT Box Profiles Baseplates Angle Brace - Outdoor

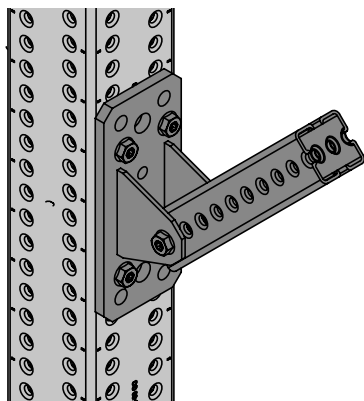

Applications

- Assembling and bracing modular support structures consisting of MT-70 and MT-80 Box Profiles
- Fastening modular support structures to concrete and steel
- Suitable for use in moderately corrosive environments

Advantages

- Versatile – use it as a Box Profile-to-Box Profile Connector, for angle braces or for fastening modular support structures to concrete and steel
- Compatible with powder-actuated threaded studs for steel and MT Thread forming Bolt Channel Connectors – for much faster, adaptable assembly
- Corrosion resistance – hot-dip galvanized to help protect against moisture and chemical corrosion

Technical Data

Material composition	Q355 or better steel
Surface finish	Outdoor Coated - HDG

MT-B-GS AB OC Angle Brace - Outdoor

Order Designation	Thickness	Weight	Technical Data	Sales pack quantity	Item number	
MT-B-GS AB OC	10 mm	1640 g	Outdoor, low to moderate pollution (C3 / C4 - low)	8 pc	2332787	

MT Box Profiles Baseplates
Angle Brace - Outdoor

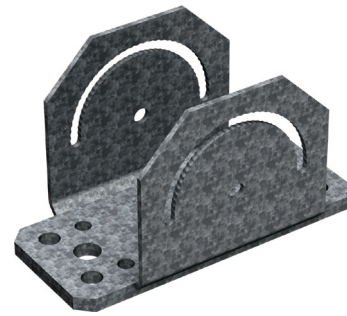
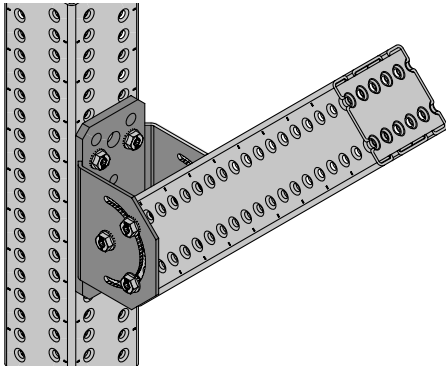

Applications

- Mounting MT-80, MT-90 and MT-100 Box Profiles on inclined steel surfaces
- Mounting MT-80, MT-90 and MT-100 at an angle ranging from +/- 90 degrees for bracing or long span supports
- Fastening heavy-duty, floor-mounted single pipe supports

Advantages

- Higher load resistance – more bolting points and stronger construction than previous Hilti Base Material Connectors
- Corrosion resistance – hot-dip galvanized to help protect against moisture and chemical corrosion
- Part of the Hilti MT system – an economical, all-in-one solution for virtually all modular MEP support structures

Technical Data

Material composition	Q355 or better steel
Surface finish	Outdoor Coated - HDG

MT-B GL AB OC Angle Brace - Outdoor

Order Designation	Thickness	Technical Data	Sales pack quantity	Item number
MT-B GL AB OC	10 mm	Outdoor, low to moderate pollution (C3 / C4 - low)	6 pc	2353811

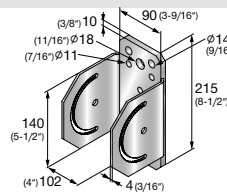

MT Box Profiles Baseplates

Starter Bracket - Outdoor

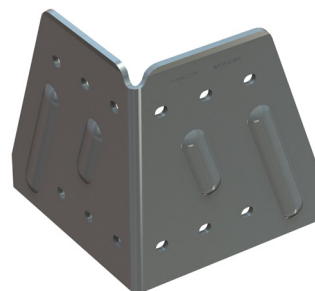
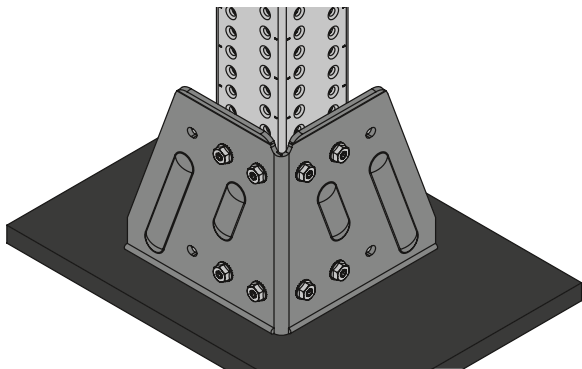

Applications

- Creating base Connectors for MT-70, MT-80, MT-90 and MT-100 Box Profiles on structural steel

Technical Data

Material composition	Q355 or better steel
Surface finish	Not Galvanized

Advantages

- Part of the Hilti MT system – an economical, all-in-one solution for virtually all modular MEP support structures
- Versatile – creates a post base connection at any location on structural steel
- Simplicity – one WS Bracket can be used for all MT Box Profiles: MT-70, 80, 90 and 100

MT-B-G WS NC Starter Bracket

Order Designation	Thickness	Weight	Technical Data	Sales pack quantity	Item number	
MT-B-G WS NC	6 mm	4345 g	Outdoor, low to moderate pollution (C3 / C4 - low)	4 pc	2272109	

MT Box Profiles Baseplates

Angle Connector - Outdoor

5

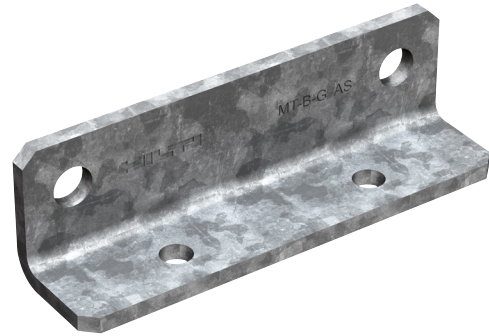
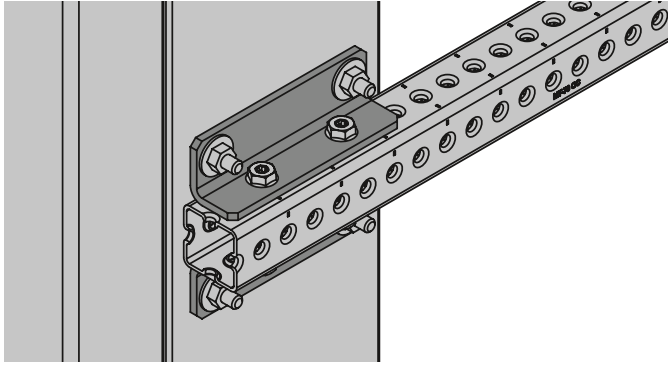

Applications

- Fastening MT-70 and MT-80 Box Profiles to steel beams
- Suitable for use in moderately corrosive environments

Advantages

- A faster and more economical solution for installing Box Profile cantilevers directly to steel beams
- Compatible with powder-actuated threaded studs for steel and MT Thread forming Bolt Channel Connectors – for much faster, adaptable assembly
- Corrosion resistance – hot-dip galvanized to help protect against moisture and chemical corrosion

Technical Data

Material composition	Q355 or better steel
Surface finish	Outdoor Coated - HDG

MT-B-G AS OC Base Connector (outdoor)

Order Designation	Thickness	Weight	Technical Data	Sales pack quantity	Item number	
MT-B-G AS OC	6 mm	560 g	Outdoor, low to moderate pollution (C3 / C4 - low)	10 pc	2332781	

MT Box Profiles Baseplates

90° Connectors - Outdoor

5

Technical Data Baseplate

Item image	Load drawing	Order Designation	+ Fz	- Fz	± Fx	± Fy
		MT-B-GS T OC	25,9 kN	15,0 kN	20,4 kN	8,5 kN
		MT-B-GS O4U OC	26,4	18,0 kN	53,9 kN	16,0 kN
		MT-B-GL O4C OC	14,7 kN	14,47 kN	44,3 kN	10,1 kN
		MT-B-GL O4 OC	55,2 kN	55,2 kN	122,4 kN	55,2 kN
		MT-B-GXL O4 OC	93,4 kN	93,4 kN	145,7 kN	87,7 kN
		MT-B-GXL S1 OC	14,9 kN	14,9 kN	74,7 kN	14,9 kN
		MT-B-GXL S2 OC	14,9 kN	14,9 kN	66,1 kN	14,9 kN

Design notes

- Shown load values are recommended values with partial safety factors for actions and resistance included
- Design value = 1.5 * recommended value
- The design resistance of the products is defined in accordance with EN1993

MT Box Profiles Baseplates

90° Connectors, Angle Brace, Starter Bracket - Outdoor

5

Technical Data Base Connector

Item image	Load drawing	Order Designation	+ Fz	- Fz	± Fx	± Fy
		MT-B-GXL S3 OC	14,9 kN	14,9 kN	40,2 kN	14,9 kN

Design notes

- Shown load values are recommended values with partial safety factors for actions and resistance included
- Design value = 1.5 * recommended value
- The design resistance of the products is defined in accordance with EN1993

Technical Data Angle Brace

Item image	Load drawing	Order Designation	+ Fz	± Fx	± Fy
		MT-B-GS AB OC	3,0 kN	18,1 kN	18,1 kN

Design notes

- Shown load values are recommended values with partial safety factors for actions and resistance included
- Design value = 1.5 * recommended value
- The design resistance of the products is defined in accordance with EN1993

Technical Data Starter Bracket

Item image	Load drawing	Order Designation	+ Fz	- Fz	± Fx	± Fy
		MT-B-GS WS NC	84,7 kN	84,7 kN	22,2 kN	22,2 kN

Design notes

- Load values are only valid if MT-90 Box Profile are used.
- Shown load values are recommended values with partial safety factors for actions and resistance included
- Design value = 1.5 * recommended value
- The design resistance of the products is defined in accordance with EN1993

Technical Data Base Connector

Item image	Load drawing	Order Designation	+ Fz	± Fx	± Fy
		MT-B-G AS OC	23,9 kN	47,1 kN	7,1 kN

Design notes

- Shown load values are recommended values with partial safety factors for actions and resistance included
- Design value = 1.5 * recommended value
- The design resistance of the products is defined in accordance with EN1993

MT Box Profiles Baseplates

90° Connector - Outdoor

Operation Instruction

MT-B-GS T OC

2294558-07.2020

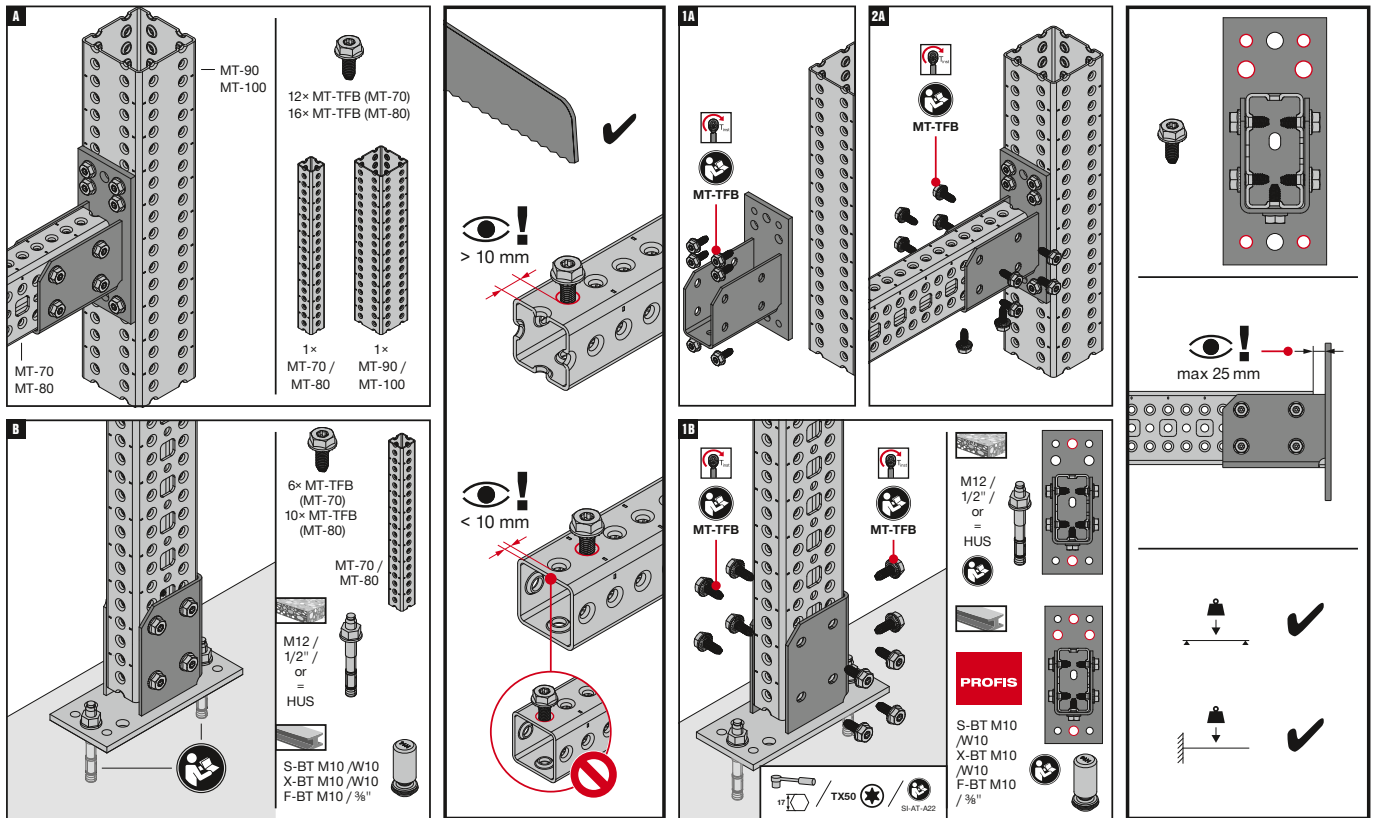

The latest IFU (Instruction for Use) is available on Hilti Online. Please check for any revisions before installing the product.

MT-B-GS O4U OC

2294559-06.2020

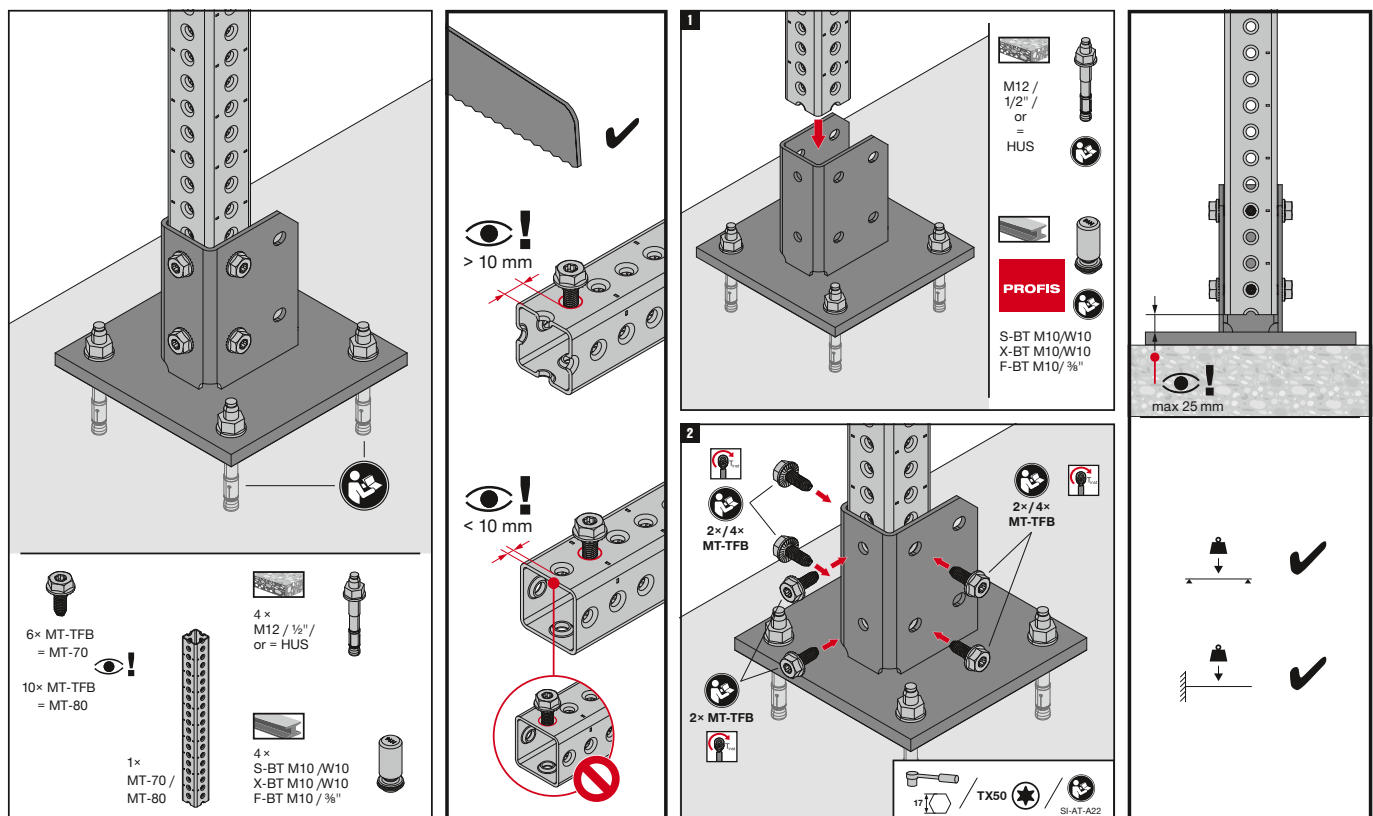

The latest IFU (Instruction for Use) is available on Hilti Online. Please check for any revisions before installing the product.

MT Box Profiles Baseplates

90° Connector - Outdoor

Operation Instruction

MT-B-GL O4C OC

2347956-12.2021

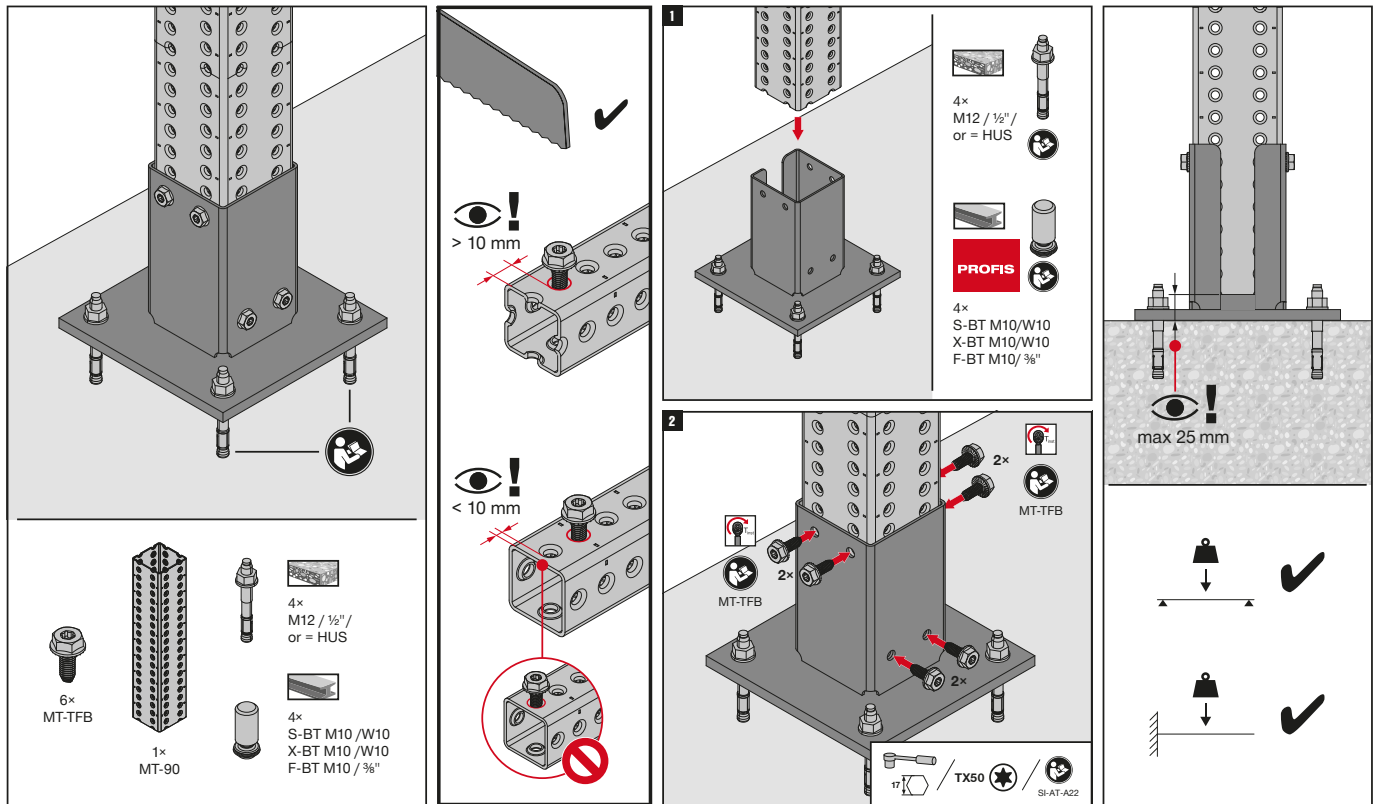

The latest IFU (Instruction for Use) is available on Hilti Online. Please check for any revisions before installing the product.

MT-B-GL O4 OC / MT-B-GXL O4 OC

2294690-05.2020

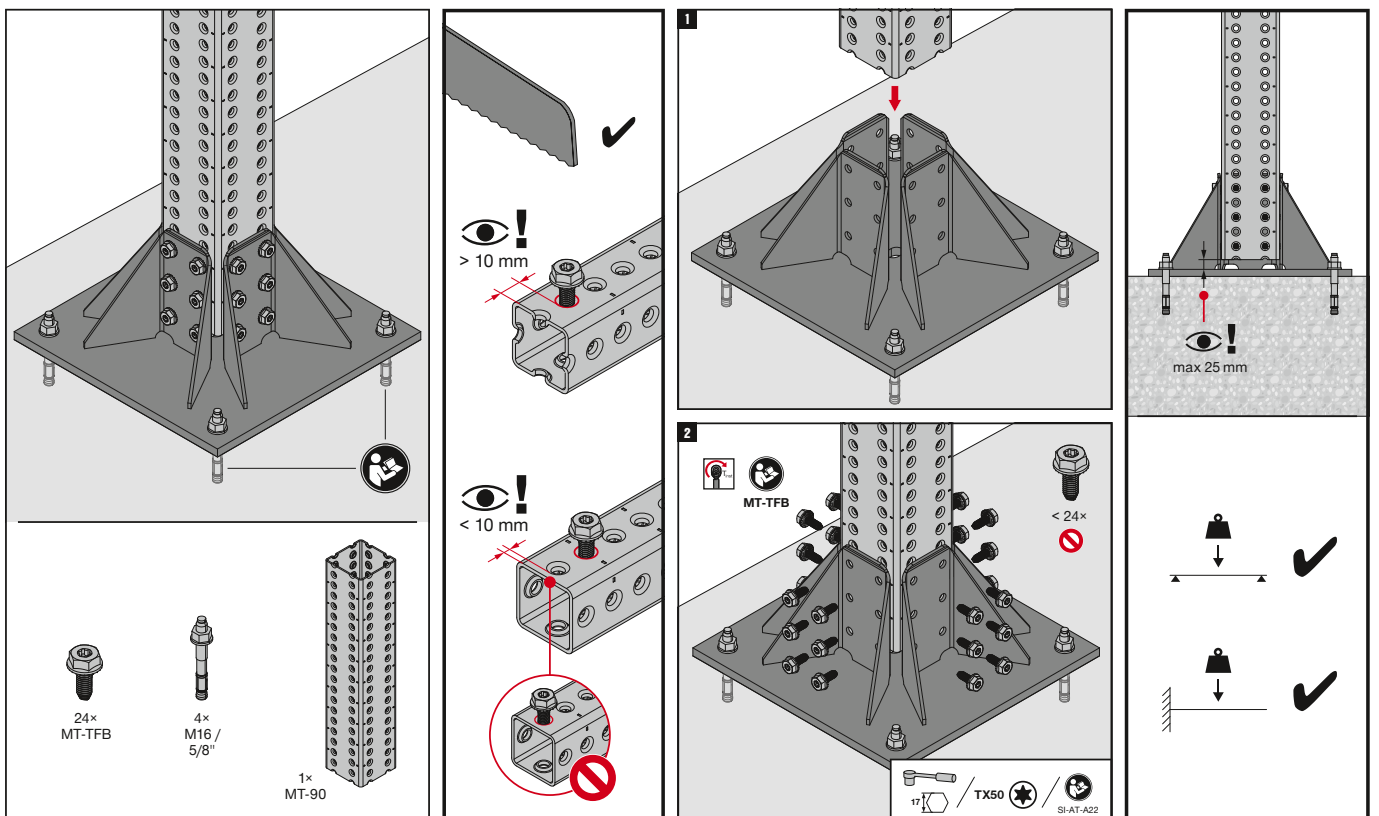

The latest IFU (Instruction for Use) is available on Hilti Online. Please check for any revisions before installing the product.

MT Box Profiles Baseplates

90° Connector, Angle Brace - Outdoor

Operation Instruction

MT-B-GXL S1 OC / MT-B-GXL S2 OC / MT-B-GXL S3 OC

2294692-09.2020

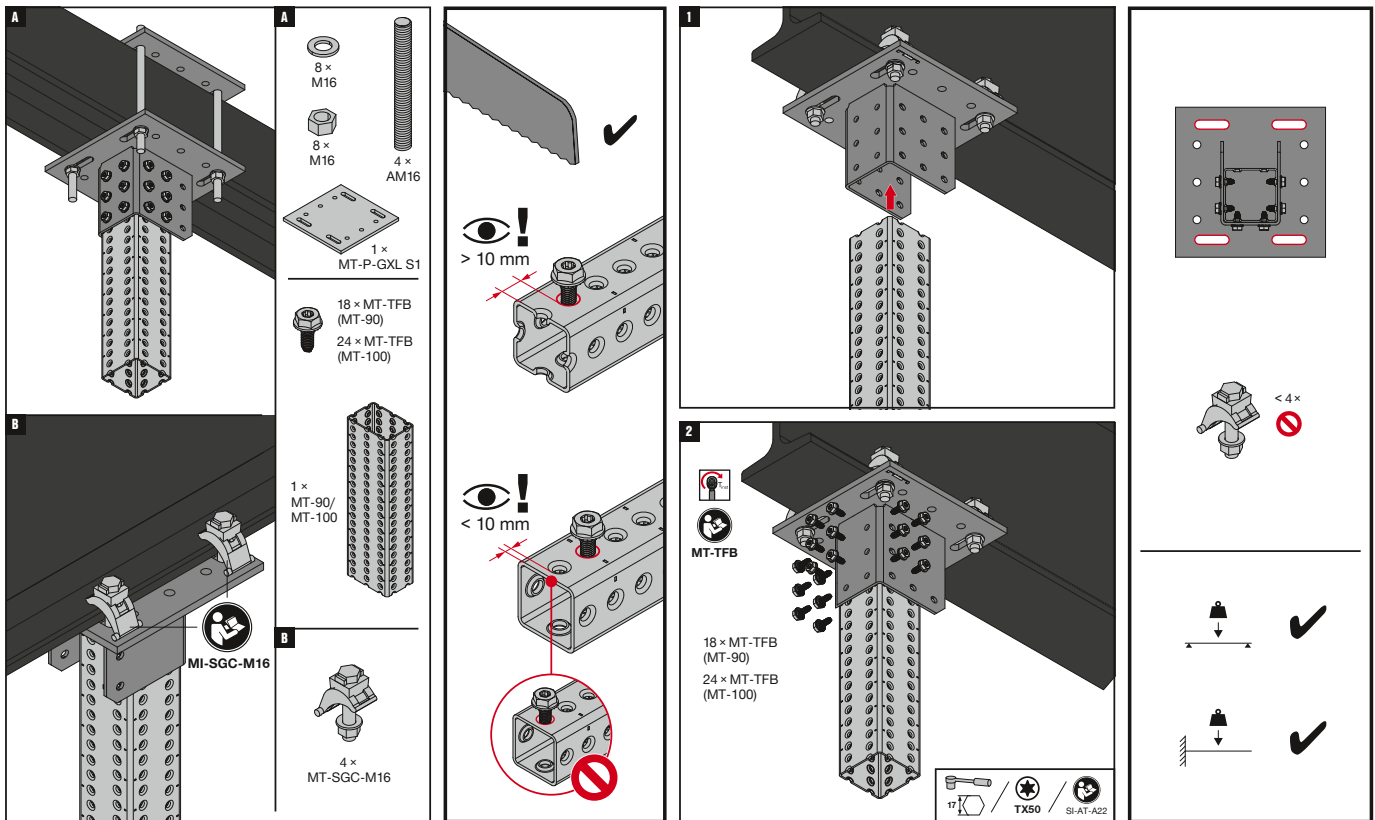

The latest IFU (Instruction for Use) is available on Hilti Online. Please check for any revisions before installing the product.

MT-B-GS AB OC

2334522-06.2021

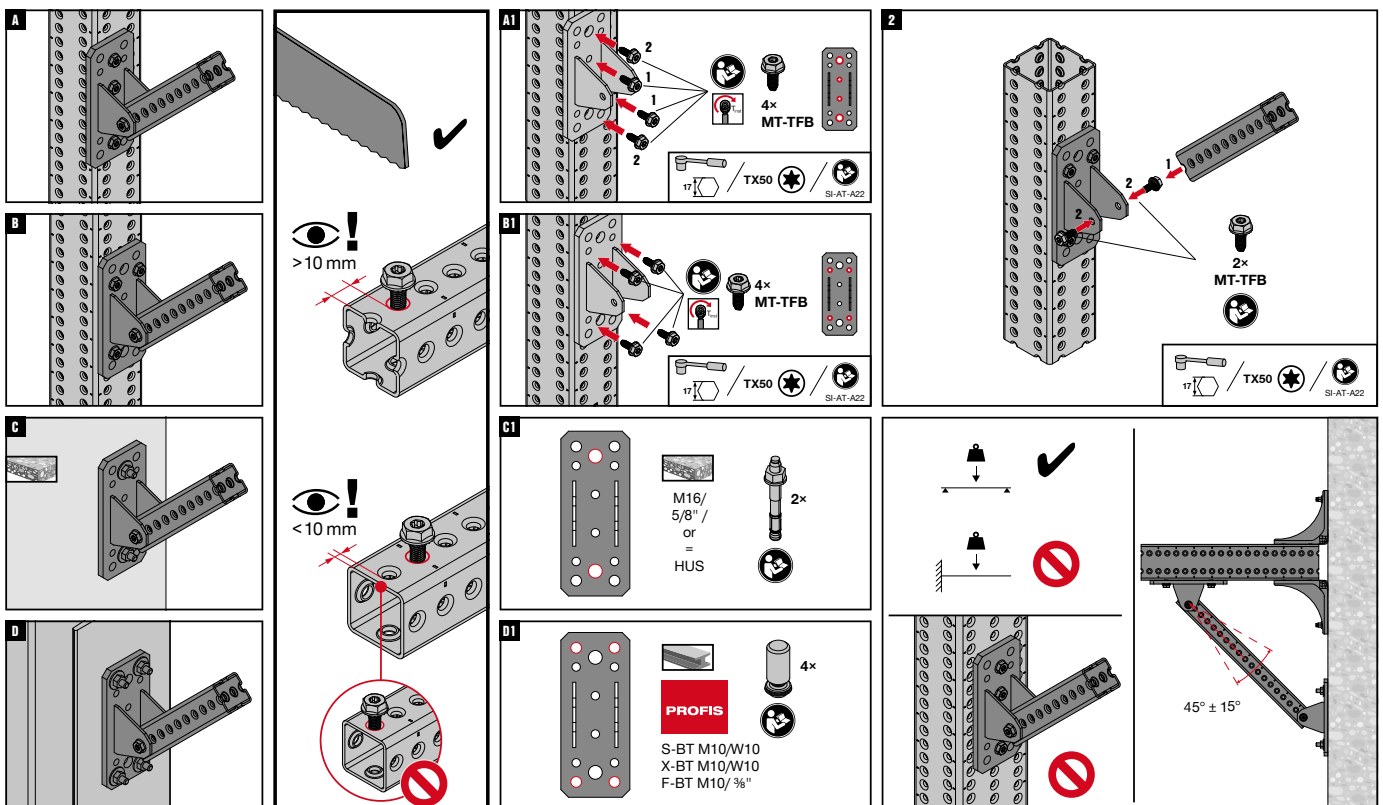

The latest IFU (Instruction for Use) is available on Hilti Online. Please check for any revisions before installing the product.

MT Box Profiles Baseplates
Angle Brace, Starter Bracket - Outdoor

Operation Instruction
MT-B-GL AB OC

2359996-04.2022

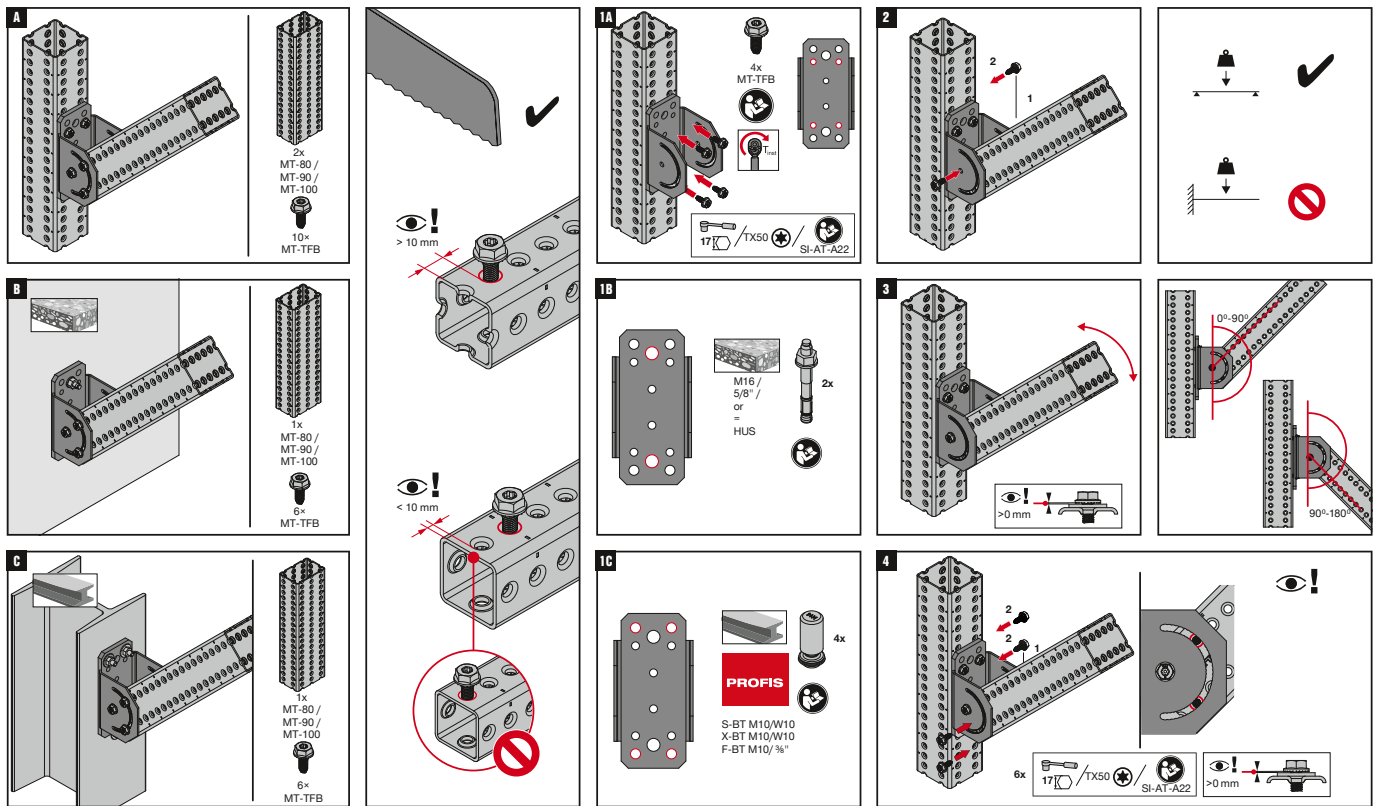

The latest IFU (Instruction for Use) is available on Hilti Online. Please check for any revisions before installing the product.

MT-B-G WS NC

2294693-07.2020

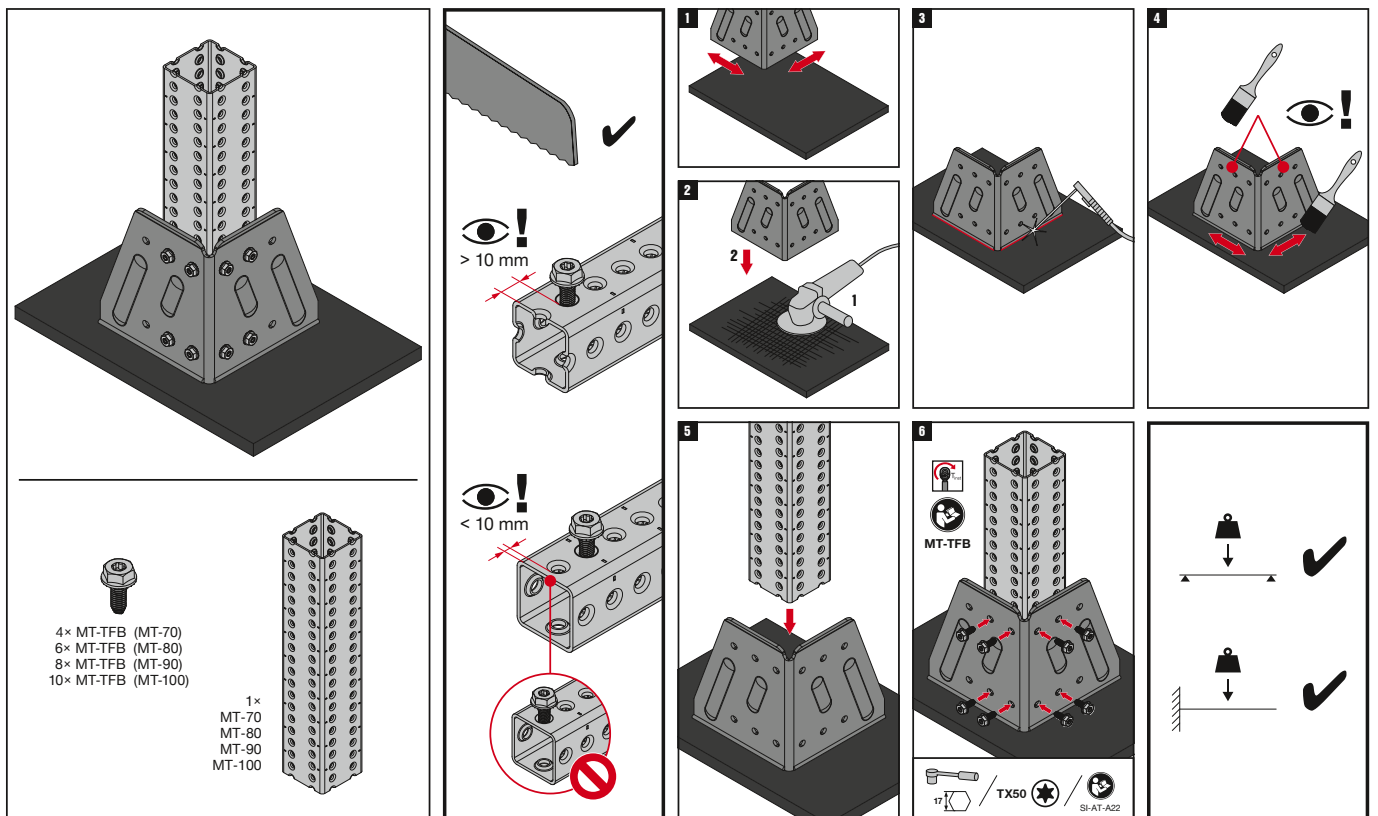

The latest IFU (Instruction for Use) is available on Hilti Online. Please check for any revisions before installing the product.

MT Box Profiles Baseplates

Angle Connector - Outdoor

Operation Instruction

MT-B-G AS OC

2334552-07 2020

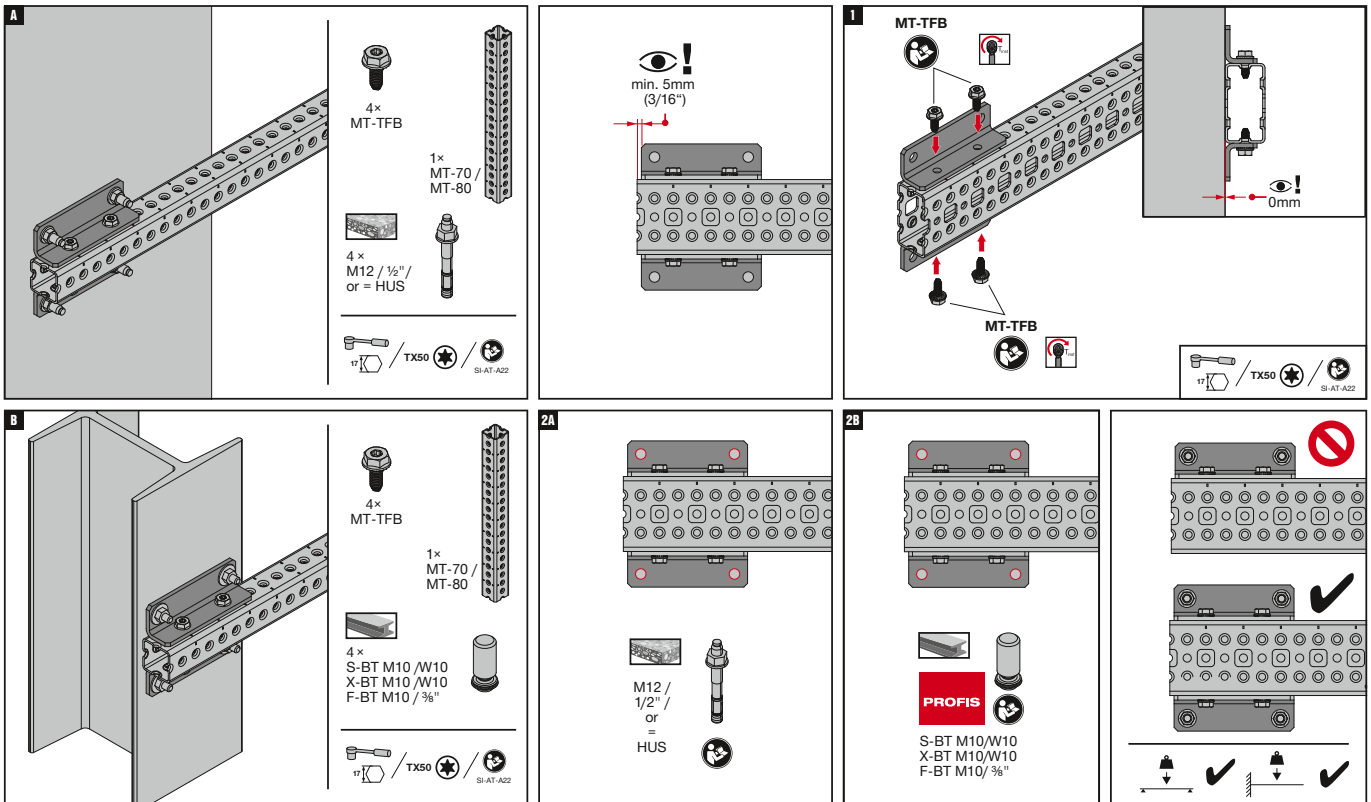

The latest IFU (Instruction for Use) is available on Hilti Online. Please check for any revisions before installing the product.

MT Box Profiles Baseplates
Modular Base plate - Outdoor

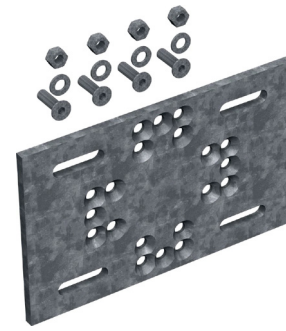
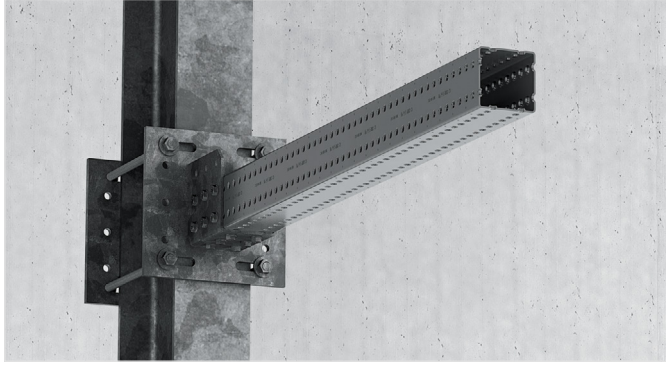

Applications

- Attaching triangular bracing and grid Base Material Connectors to structural steel without the need for direct fastening
- Bracing connections to steel, Box Profile cantilevers with MT-70/80 to steel and back plates for sandwich connections

Advantages

- Part of the Hilti MT system – an economical, all-in-one solution for virtually all modular MEP support structures
- Lighter MEP support structures – save weight compared with MI and welded solutions
- Compatible with the Hilti Adaptive Torque system – use a cordless impact wrench to tighten nuts to the correct pretension more economically (compatible tool and SI-AT module required)

Technical Data

Material composition	Q355 or better steel
Surface finish	Outdoor Coated - HDG

MT-P-G S1 / S2 / S3 OC Modular Base plate - Outdoor

Order Designation	Thickness	Weight	Technical Data	Sales pack quantity	Item number	
MT-P-G S1 OC	12 mm	3368g	Outdoor, low to moderate pollution (C3 / C4 - low)	2 Base Material Connectors, 8 bolts, 8 washers and 8 nuts	2343199	
MT-P-G S2 OC	12 mm	3302g		2 Base Material Connectors, 8 bolts, 8 washers and 8 nuts	2343280	
MT-P-G S3 OC	12 mm	4131g		2 Base Material Connectors, 8 bolts, 8 washers and 8 nuts	2343281	

MT Box Profiles Baseplates

Modular Base plate - Outdoor

5

MT-P-GM S1 / S2 / S3 OC Modular Base plate - Outdoor

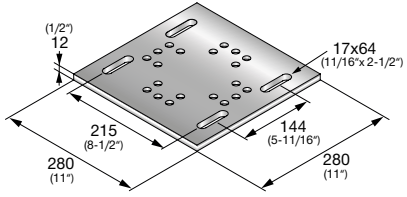
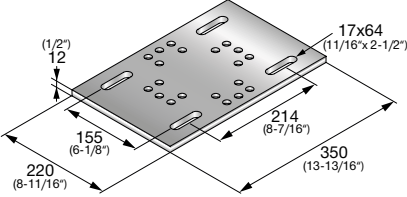
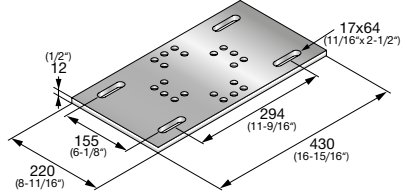
Order Designation	Thickness	Weight	Technical Data	Sales pack quantity	Item number	
MT-P-GM S1 OC set	12 mm	6550g	Outdoor, low to moderate pollution (C3 / C4 - low)	1 Base Material Connectors, 4 bolts, 4 washers and 4 nuts	2345353	
MT-P-GM S2 OC set	12 mm	6450g		1 Base Material Connectors, 4 bolts, 4 washers and 4 nuts	2345354	
MT-P-GM S3 OC set	12 mm	8100g		1 Base Material Connectors, 4 bolts, 4 washers and 4 nuts	2345355	

MT Box Profiles Baseplates

Connections To Steel - Outdoor

Operation Instruction

MT-B-GXL S1 OC / MT-B-GXL S2 OC / MT-B-GXL S3 OC

2294692-09 2020

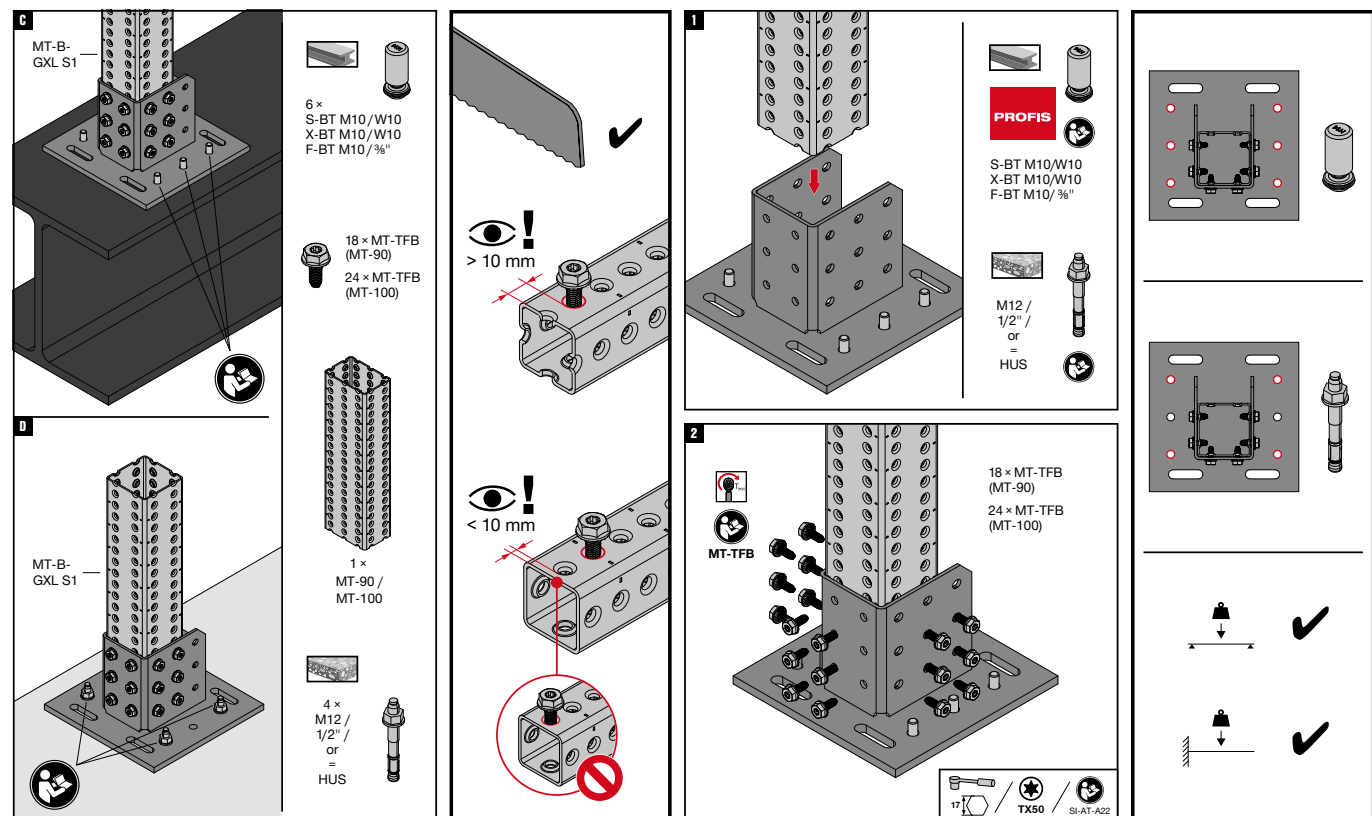
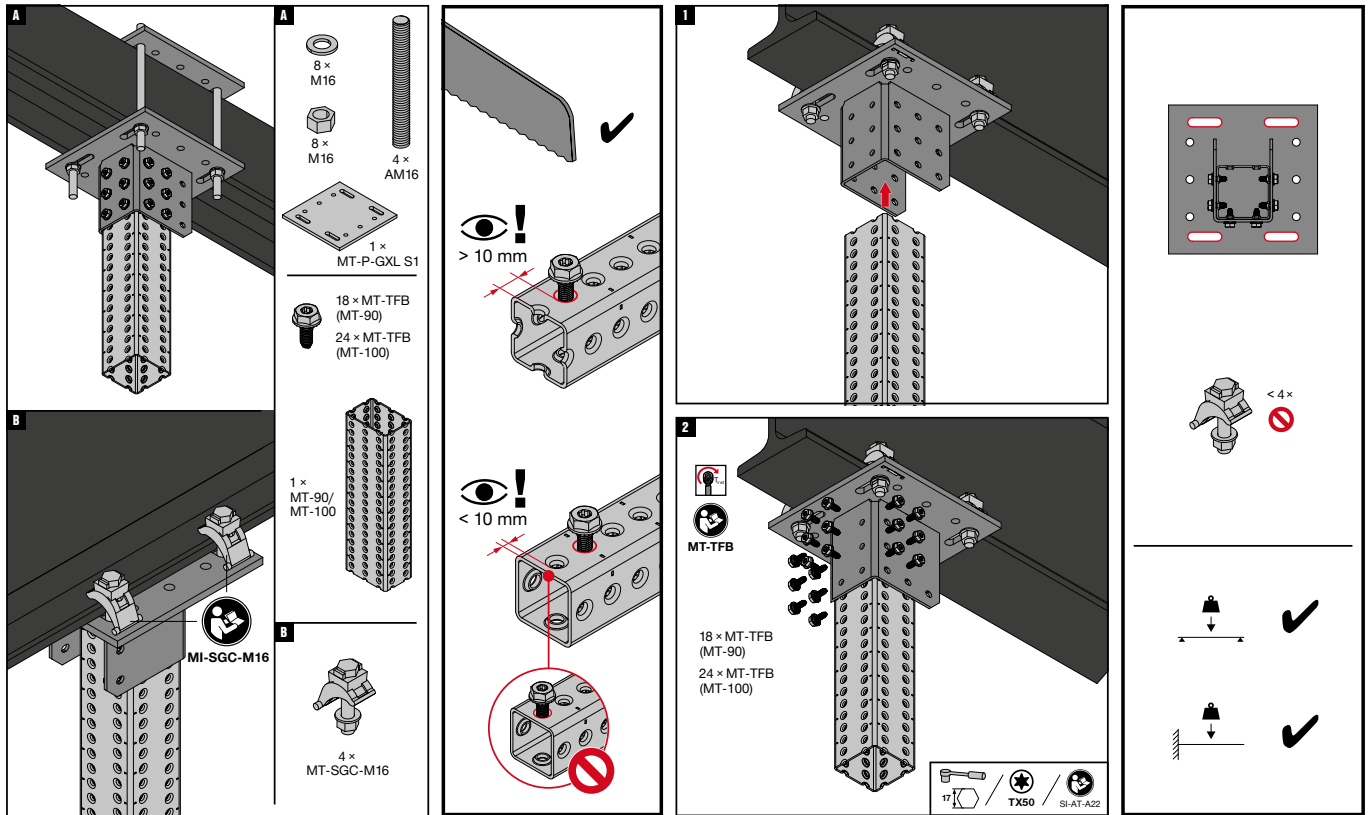

The latest IFU (Instruction for Use) is available on Hilti Online. Please check for any revisions before installing the product.

MT Box Profiles Baseplates

Connections To Steel - Outdoor

Operation Instruction

MT-P-GM S1 OC + MT-P-G S1 OC / MT-P-GM S2 OC + MT-P-G S2 OC / MT-P-GM S3 OC + MT-P-G S3 OC

2347908-11.2021

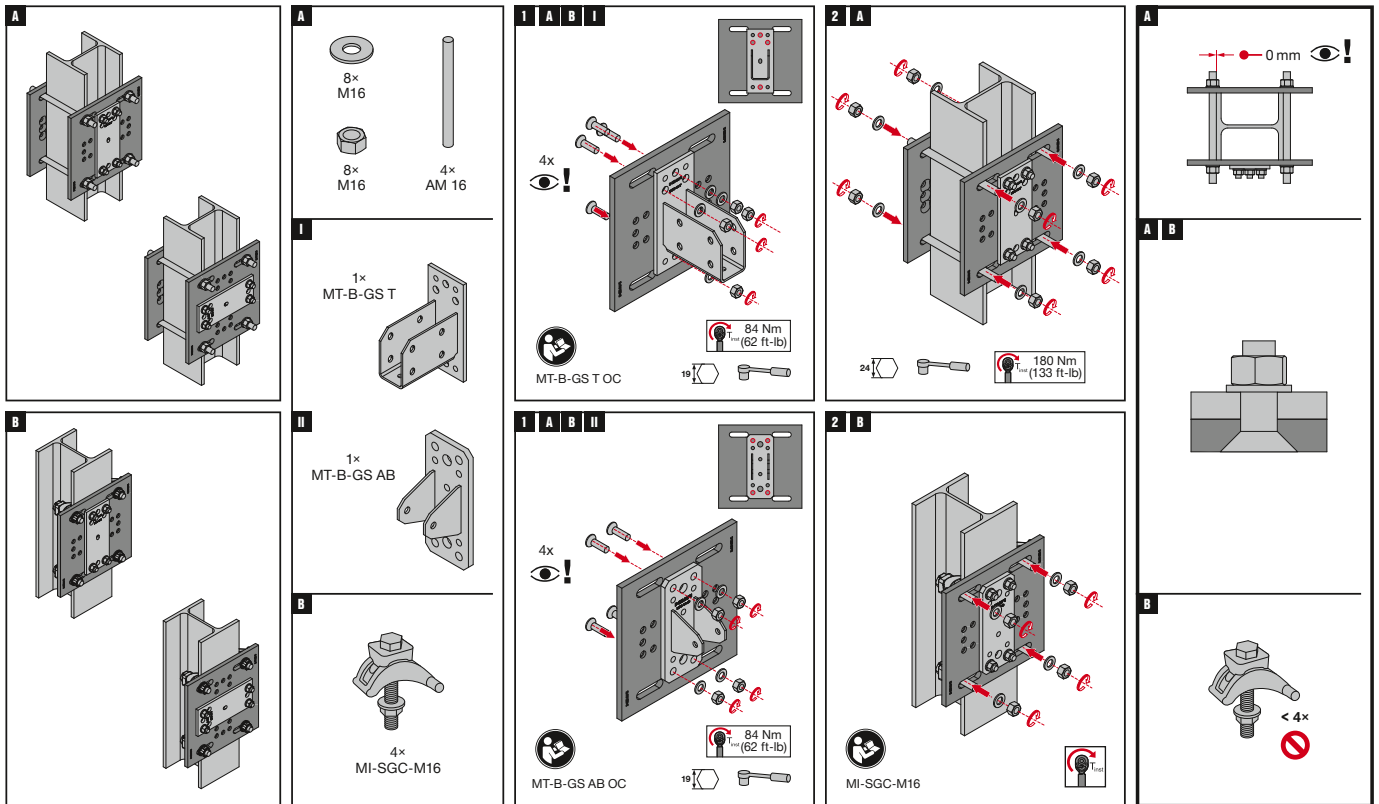

The latest IFU (Instruction for Use) is available on Hilti Online. Please check for any revisions before installing the product.

6. MT Media Fixation

MT Media Fixation for Open C-Channels Threaded Fixation plate

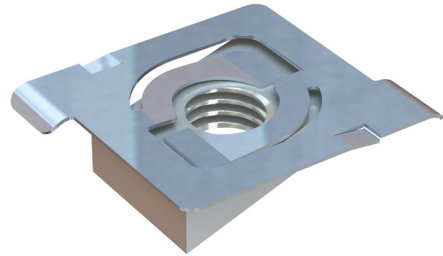
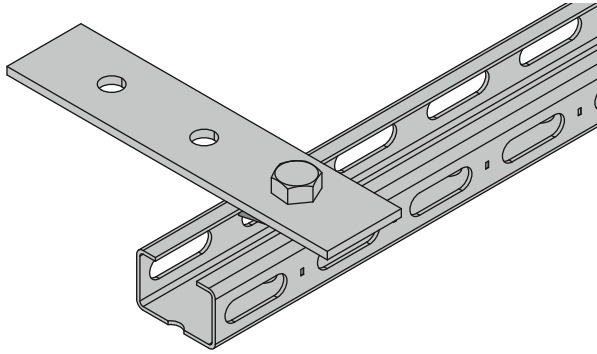

Applications

- Attaching MEP Media (hardware) to MT C-when no shear load resistance is required

Technical Data

Material composition	Q235B or better steel
Surface finish	Pre-galvanized - for dry indoor use only

Advantages

- Part of the Hilti MT system – an economical, all-in-one solution for virtually all modular MEP support structures
- Simple Media Fixation method where no shear force resistance required
- Easy to install – insert into C-Channel using a one-handed “push-and-twist” motion

MT-FPT M8 / M10 / M12 Threaded Fixation plate

Order Designation	Technical Data	Sales pack quantity	Item number
MT-FPT M8	Dry indoor conditions (C1) Indoor with temporary condensation (C2)	50 pc	2281867
MT-FPT M10		50 pc	2282193
MT-FPT M12		50 pc	2282195

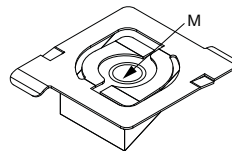

MT Media Fixation for Open C-Channels

Threaded Fixation plate - Outdoor

6

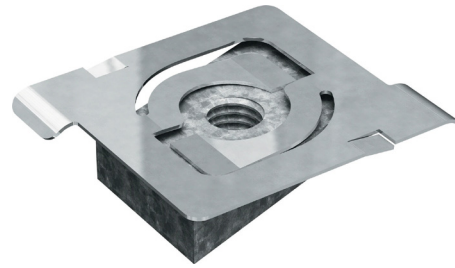
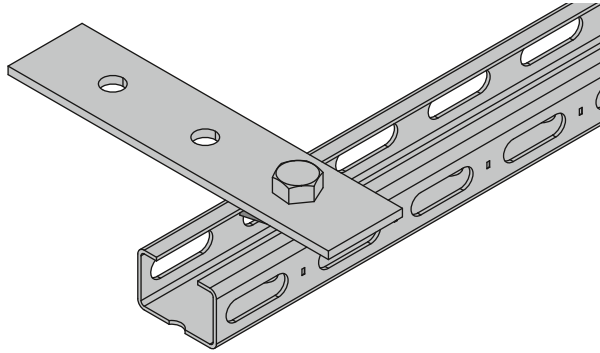

Applications

- Attaching MEP Media (hardware) to MT C-when no shear load resistance is required

Technical Data

Material composition	Q235B or better
Surface finish	Hot-dip galvanized - for outdoor use

Advantages

- Part of the Hilti MT system – an economical, all-in-one solution for virtually all modular MEP support structures
- Simple Media Fixation method where no shear force resistance required
- Easy to install – insert into C-Channel using a one-handed “push-and-twist” motion

MT-FPT OC M8 / M10 / M12 OC Threaded Fixation plate - Outdoor

Order Designations	Technical Data	Sales pack quantity	Item number
MT-FPT M8 OC	Outdoor, low to moderate pollution (C3 / C4 - low)	50 pc	2282192
MT-FPT M10 OC		50 pc	2282194
MT-FPT M12 OC		50 pc	2282196

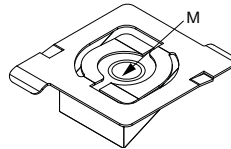

MT Media Fixation for Open C-Channels

Threaded Fixation plate

6

Operation Instruction

MT-FPT / MT-FPT OC

2294627-07.2020

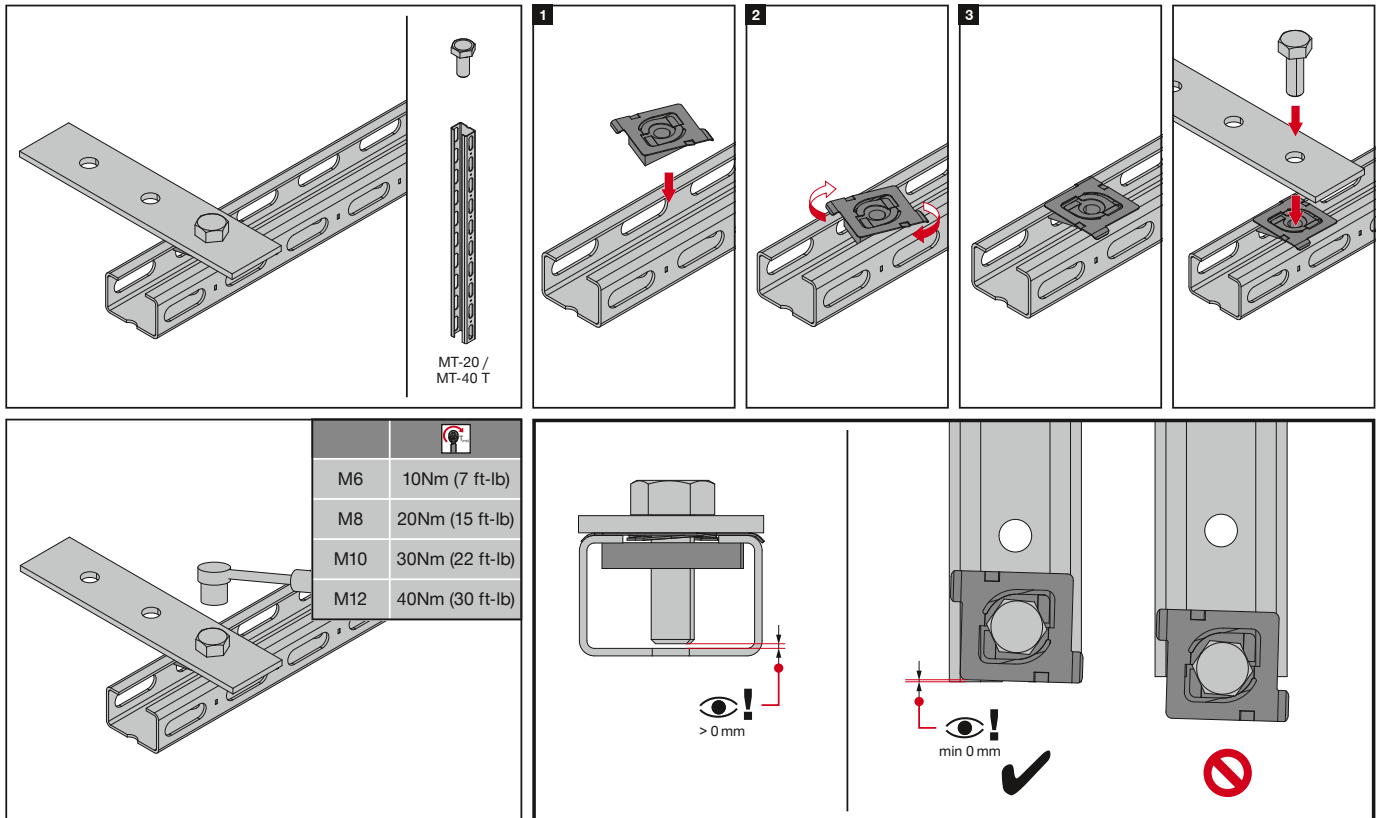

The latest IFU (Instruction for Use) is available on Hilti Online. Please check for any revisions before installing the product.

MT Media Fixation for Open C-Channels

Threaded Fixation plate

6

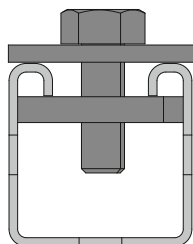

Applications

- Attaching MEP Media (hardware) to MT C-when no shear load resistance is required
- Suitable for use in dry, indoor environments

Advantages

- Part of the Hilti MT system – an economical, all-in-one solution for virtually all modular MEP support structures
- Simple Media Fixation method where no shear force resistance required

Technical Data

Material composition	Q235B or better steel
Surface finish	Pre-galvanized - for dry indoor use only

MT-FP M6 / M8 / M10 / M12 / M16 Threaded Fixation plate

Order Designation	Technical Data	Sales pack quantity	Item number
MT-FP M6	Dry indoor conditions (C1) Indoor with temporary condensation (C2)	100 pc	2273653
MT-FP M8		100 pc	2273655
MT-FP M10		100 pc	2273657
MT-FP M12		100 pc	2273659
MT-FP M16		100 pc	2273671

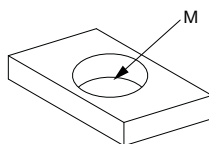

MT Media Fixation for Open C-Channels

Threaded Fixation plate - Outdoor

6

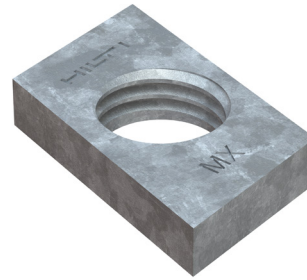
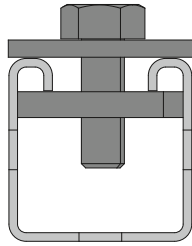

Applications

- Attaching MEP Media (hardware) to MT C-when no shear load resistance is required
- Suitable for use in moderately corrosive environments

Advantages

- Part of the Hilti MT system – an economical, all-in-one solution for virtually all modular MEP support structures
- Simple Media Fixation method where no shear force resistance required
- Corrosion resistance – hot-dip galvanized to help protect against moisture and chemical corrosion

Technical Data

Material composition	Q235B or better steel
Surface finish	Hot-dip galvanized - for outdoor use

Threaded Fixation plate - Outdoor

Item designation	Technical Data	Sales pack quantity	Item number
MT-FP M6 OC	Outdoor, low to moderate pollution (C3 / C4 - low)	100 pc	2273654
MT-FP M8 OC		100 pc	2273656
MT-FP M10 OC		100 pc	2273658
MT-FP M12 OC		100 pc	2273670
MT-FP M16 OC		100 pc	2273672

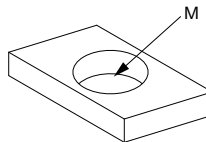

MT Media Fixation for Open C-Channels

Threaded Fixation plate

6

Operation Instruction

MT-FP / MT-FP OC

2298189-07.2020

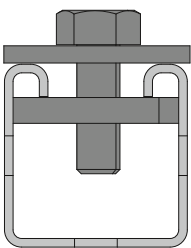

size	Torque (Nm)
M6	5
M8	9
M10	15
M12	20
M16	20

1

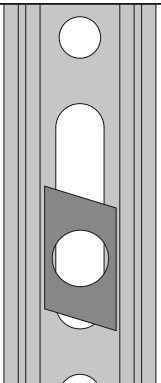
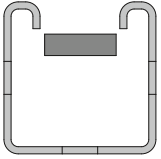
2



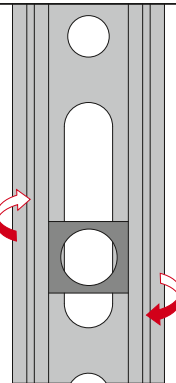
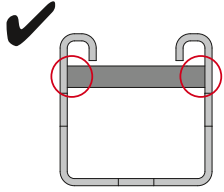

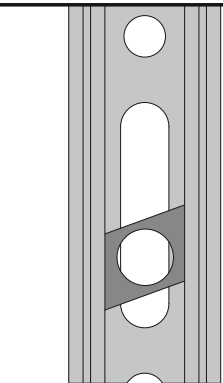
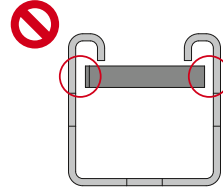
The latest IFU (Instruction for Use) is available on Hilti Online. Please check for any revisions before installing the product.

MT Media Fixation for Open C-Channels

Washer - Outdoor

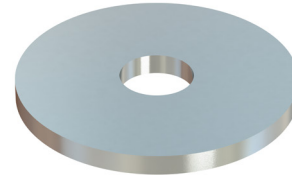
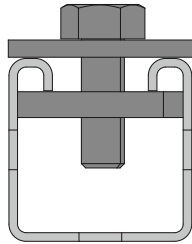
6



Applications

- Assembling C-Trapeze for piping supports

Advantages

- Part of the Hilti MT system – an economical, all-in-one solution for virtually all modular MEP support structures
- Versatile solution for fastening pipe rings to the Open face of MT C-Channels using MT-FP threaded plates

Technical Data

Material composition	Q235 or better steel
Surface finish	Outdoor Coated - HDG

MT-ZW M8 / M10 / M12 / M16 OC Washer - Outdoor

Order Designation	Weight	Technical Data	Sales pack quantity	Item number
MT-ZW M8 OC	2 g	Outdoor, low to moderate pollution (C3 / C4 - low)	100 pc	2283114
MT-ZW M10 OC	4 g		100 pc	2283115
MT-ZW M12 OC	6 g		100 pc	2283116
MT-ZW M16 OC	11 g		100 pc	2283117

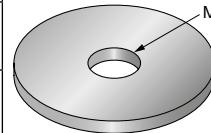

MT Media Fixation for Open C-Channels

U-bolt Fixation Angle

6

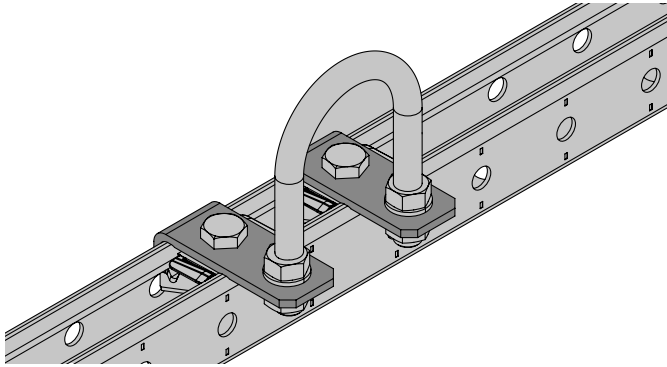

Applications

- Attaching MEP Media to MT C-Channels
- Suitable for use in dry, indoor environments

Advantages

- Part of the Hilti MT system – an economical, all-in-one solution for virtually all modular MEP support structures
- Easy to install – compatible with the Hilti MT Twist-Lock, a faster alternative to spring nuts for assembling a modular support system
- Simple Media Fixation method

Technical Data

Material composition	Q235B or better steel
Surface finish	Pre-galvanized - for dry indoor use only

MT-FA-C M8 / M10 / M12 / M16 U-bolt Fixation Angle

Order designations	Technical Data	Sales pack quantity	Item number	
MT-FA-C M8	Dry indoor conditions (C1) Indoor with temporary condensation (C2)	20 pc	2273686	
MT-FA-C M10		20 pc	2273688	
MT-FA-C M12		20 pc	2273690	
MT-FA-C M16		20 pc	2273692	

MT Media Fixation for Open C-Channels U-bolt Fixation Angle - Outdoor

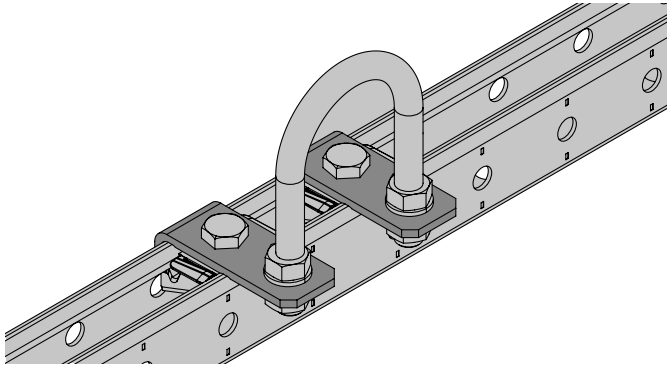

Applications

- Attaching MEP Media to MT C-Channels
- Suitable for use in moderately corrosive environments

Technical Data

Material composition	Q355B or better steel
Surface finish	Hot-dip galvanized - for outdoor use

Advantages

- Part of the Hilti MT system – an economical, all-in-one solution for virtually all modular MEP support structures
- Easy to install – compatible with the Hilti MT Twist-Lock, a faster alternative to spring nuts for assembling a modular support system
- Simple Media Fixation method

MT-FA-C OC U-bolt Fixation Angle

Order designation	Technical Data	Sales pack quantity	Item number	
MT-FA-C M8 OC	Outdoor, low to moderate pollution (C3 / C4 - low)	20 pc	2273687	
MT-FA-C M10 OC		20 pc	2273689	
MT-FA-C M12 OC		20 pc	2273691	
MT-FA-C M16 OC		20 pc	2273652	

MT Media Fixation for Open C-Channels

U-bolt Fixation Angle

6

Operation Instruction

MT-FA-C M8/M10/M12/M16 / MT-FA-C M8/M10/M12/M16 OC

2294628-07.2020

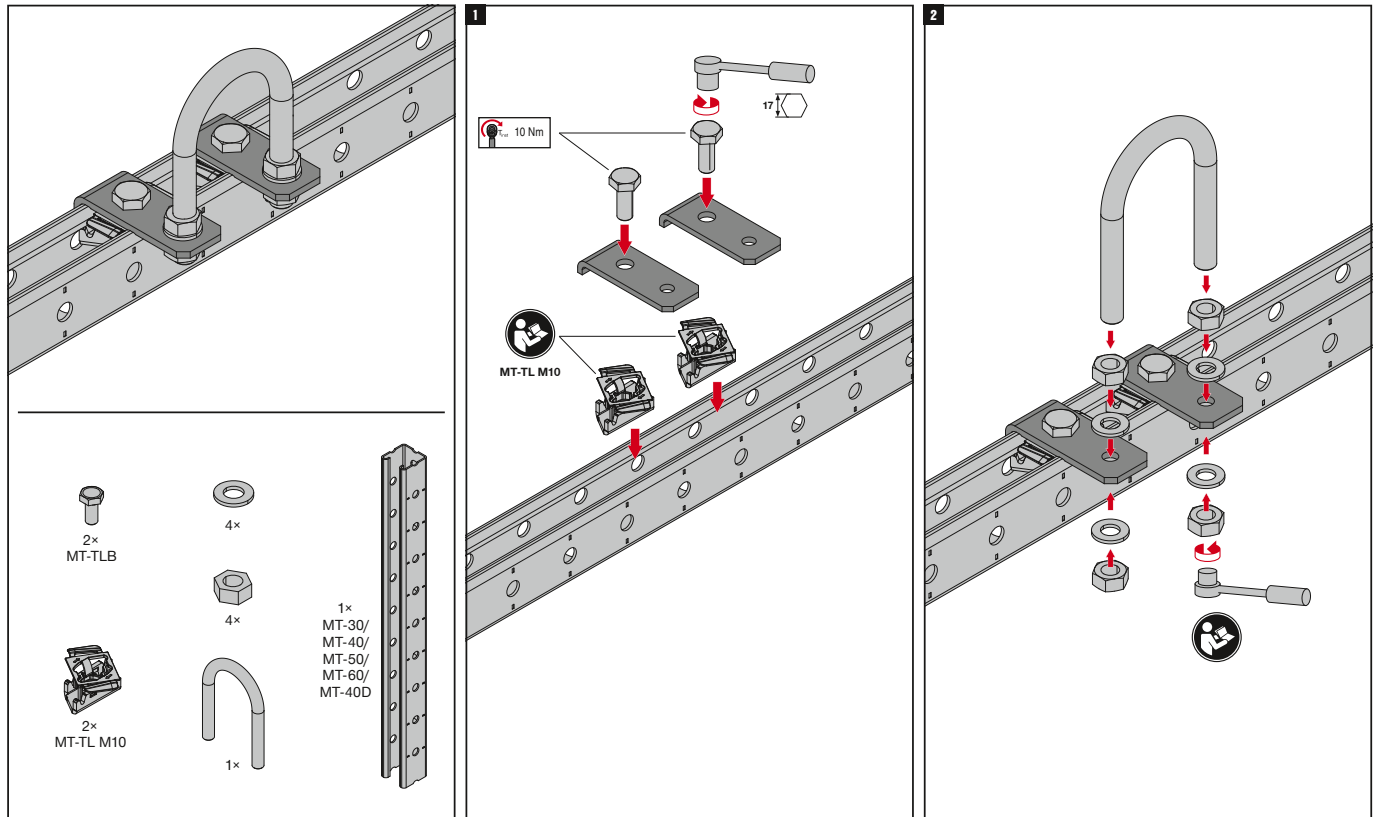

The latest IFU (Instruction for Use) is available on Hilti Online. Please check for any revisions before installing the product.

MT-AS B OC Pipe ring saddle

Pipe ring saddle for connecting threaded components to MT C-Channels, in moderately corrosive environments

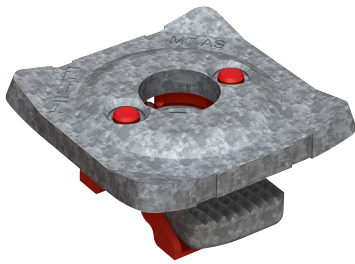

Technical Data

Material composition	High Strength Steel
Surface finish	Outdoor Coated - Multilayer

Applications

- Attaching MEP Media (hardware) to MT C-Channel Profiles when shear load resistance is required
- Multidisciplinary MEP support structures combining a wide range of Media such as air ducts, cable trays, piping, etc.
- Process piping for energy and industry Applications
- Ceiling-mounted MEP support structures with heavy loads such as ceiling grids and utility piping and drainage
- Integrated modules and skids to support industrial pipes and other heavy-duty building services
- Floor-mounted MEP support structures with heavy loads
- Wall-mounted MEP support structures for heavy-duty, industrial pipes
- Assembling support structures for instrumentation and stands
- Suitable for use in moderately corrosive environments

Advantages

- Fewer work steps – faster installations in under three work steps and serrated design to help pre-secure connecting elements for better handling
- Simple to adjust – can be inserted and adjusted at any point along the Profile, with 2.5 mm (1/8") incremental adjustments
- Reliable installations – approved for shear loads for secure connections
- Part of the Hilti MT System – an economical, all-in-one solution for virtually all modular MEP support structures
- Corrosion resistance – hot-dip galvanized to help protect against moisture and chemical corrosion

MT-AS B OC Pipe ring saddle

Order Designation	Technical Data	Sales pack quantity	Item number	
MT-AS B M12 OC	Outdoor, low to moderate pollution (C3 / C4 - low)	25 pcs	2430772	
MT-AS B M16 OC		25 pcs	2430773	

MT-AS Pipe clamp saddle

Pipe clamp saddle for connecting threaded components to MT Channels

6



Applications

- Fastening pipes to MEP support structures
- Fastening air ducts to MEP support systems
- Recommended for use in dry, interior environments

Advantages

- Quick connection of threaded components to the Open side of MT C-Channels
- Easy installation and positioning within MT C-Channel Openings
- Single, compact part – for higher productivity and flexibility
- Various thread sizes available
- Robust single-part design without plastic components

Technical Data

Material composition	DD11 MOD
Surface finish	Indoor-coated Electro-galvanized

MT-AS M8 Pipe Ring Saddle

Order Designation	Material composition	Technical Data	Sales pack quantity	Item number	
MT-AS M8	S235JR, DD11 MOD	Dry indoor conditions (C1) Indoor with temporary condensation (C2)	50 pc	2399684	
MT-AS M10	S235JR, DD11 MOD		50 pc	2399685	

MT-AS Pipe clamp saddle - Outdoors

Galvanized pipe clamp saddle for connecting threaded components to MT Channels

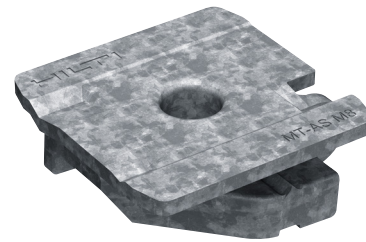

Applications

- Fastening pipes to MEP support structures
- Fastening air ducts to MEP support systems
- Suitable for use in moderately corrosive environments

Technical Data

Material composition	DD11 MOD
Surface finish	Galvanized

Advantages



- Quick connection of threaded components to the Open side of MT C-Channels
- Easy installation and positioning within MT C-Channel Openings
- Single, compact part – for higher productivity and flexibility
- Corrosion resistance – hot-dip galvanized to help protect against moisture and chemical corrosion
- Various thread sizes available
- Robust single-part design without plastic components

MT-AS OC Pipe Ring Saddle - Outdoors

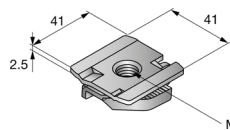
Order Designation	Material composition	Technical Data	Sales pack quantity	Item number
MT-AS M8 OC	S235JR, DD11 MOD	Outdoor, low to moderate pollution (C3 / C4 - low)	50 pc	2399686
MT-AS M10 OC	S235JR, DD11 MOD		50 pc	2399687

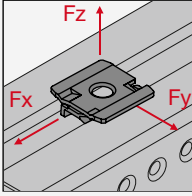

Technical Data Pipe Ring Saddle

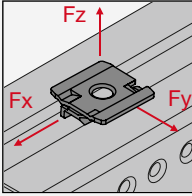
Item image	Load drawing	Order Designation	+ Fx	- Fx	+ Fy	- Fy	+ Fz	- Fz
		MT-AS M8 / MT-AS M8 OC	--	--	--	--	4,2 kN	4,2 kN
		MT-AS M10 / MT-AS M10 OC	1,0 kN	1,0 kN	--	--	4,2 kN	4,2 kN

Design notes

- Shown load values are recommended values with partial safety factors for actions and resistance included
- Design value = 1.4 * recommended value
- The design resistance of the products is defined in accordance with EN1993

MT-HL OC Wing nuts

Wing nut for connecting threaded elements directly to MT Box Profiles in moderately corrosive environments

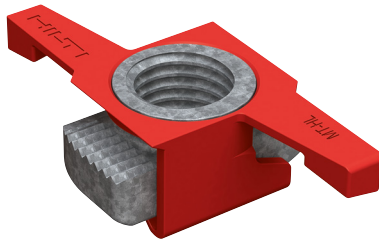

Technical Data

Material composition	High Strength Steel
Surface finish	Outdoor Coated - Multilayer

Applications

- Attaching MEP Media (hardware) to MT C-Channel Profiles when shear load resistance is required
- Multidisciplinary MEP support structures combining a wide range of Media such as air ducts, cable trays, piping, etc.
- Process piping for energy and industry Applications
- Ceiling-mounted MEP support structures with heavy loads such as ceiling grids and utility piping and drainage
- Integrated modules and skids to support industrial pipes and other heavy-duty building services
- Floor-mounted MEP support structures with heavy loads
- Wall-mounted MEP support structures for heavy-duty, industrial pipes
- Assembling support structures for instrumentation and stands
- Suitable for use in moderately corrosive environments

Advantages

- Fewer work steps – faster installations in under three work steps and serrated design to help pre-secure connecting elements for better handling
- Simple to adjust – can be inserted and adjusted at any point along the Profile, with 2.5 mm (1/8") incremental adjustments
- Reliable installations – approved for shear loads for secure connections
- Part of the Hilti MT System – an economical, all-in-one solution for virtually all modular MEP support structures
- Corrosion resistance – hot-dip galvanized to help protect against moisture and chemical corrosion

MT-HL OC Wing nuts

Order Designation	Technical Data	Sales pack quantity	Item number
MT-HL M10 OC	Outdoor, low to moderate pollution (C3 / C4 - low)	25 pcs	2430774
MT-HL M16 OC		25 pcs	2431072
MT-HL 1/2 OC		25 pcs	2431081
MT-HL M12 OC		25 pcs	2431090
MT-HL 3/8 OC		25 pcs	2431091

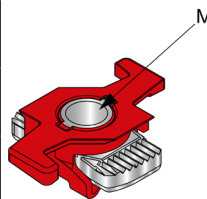

Technical Data MT-HL OC

Item image	Load drawing	Order Designation	Torque	+ Fz	Fx
		MT-HL M10 OC	40 Nm	11,5 kN	3,0 kN
		MT-HL M12 OC	84 Nm	11,5 kN	4,2 kN
		MT-HL M16 OC	84 Nm	11,5 kN	4,7 kN

MT Box Profiles Connectors

6

Operation Instruction MT-AS

2436864-04.2024

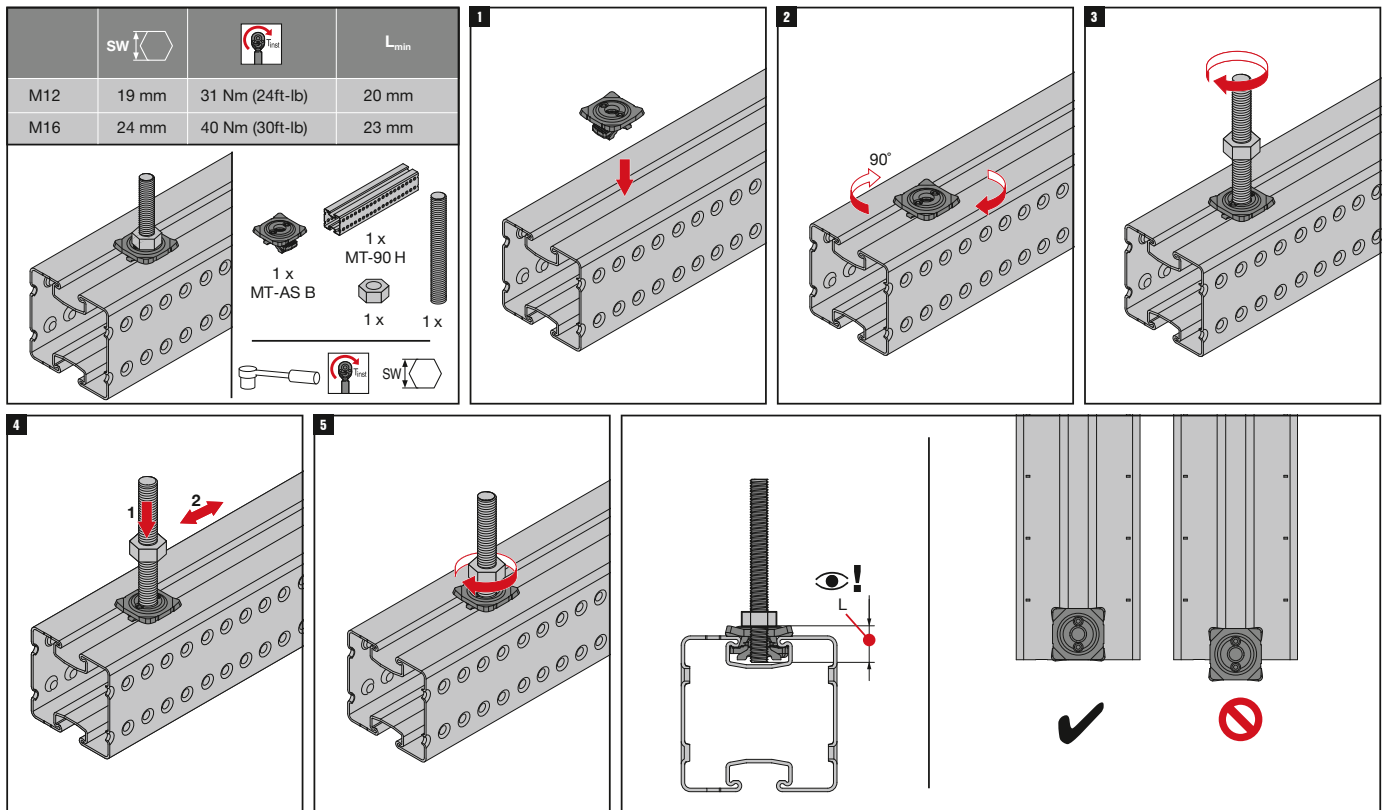

The latest IFU (Instruction for Use) is available on Hilti Online. Please check for any revisions before installing the product.

Operation Instruction MT-HL OC

2436648-04.2024

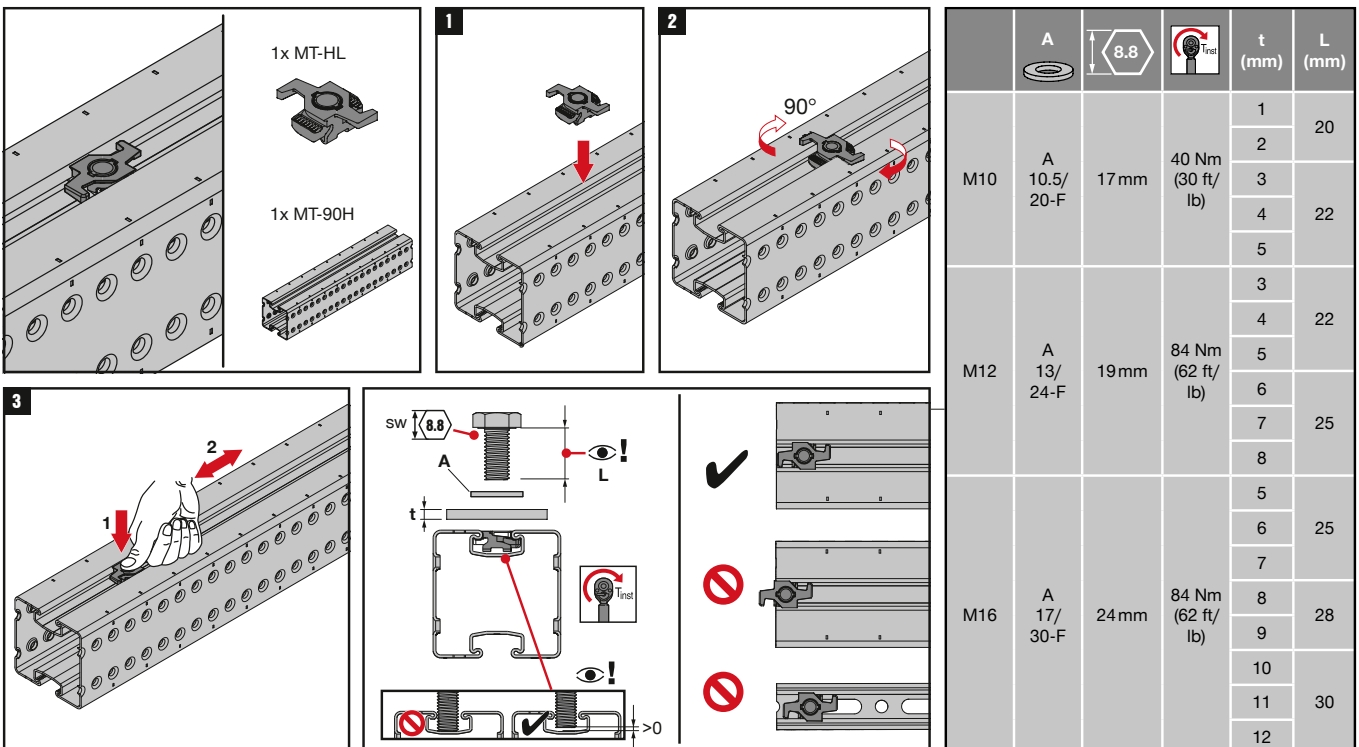

The latest IFU (Instruction for Use) is available on Hilti Online. Please check for any revisions before installing the product.

MT Media Fixation for Box Profiles

U-bolt Fixation Angle - Outdoor

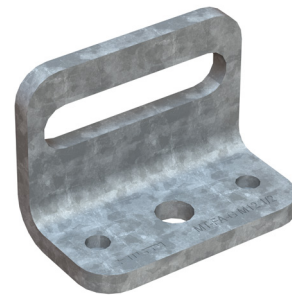
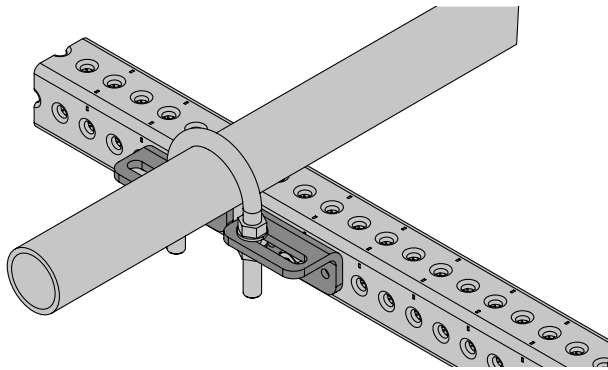

6

Applications

- Attaching MEP Media to MT Box Profiles
- Suitable for use in moderately corrosive environments

Advantages

- Part of the Hilti MT system – an economical, all-in-one solution for virtually all modular MEP support structures
- Easy to install – one-step fastening using Hilti MT-TFB thread-forming bolts
- Simple Media Fixation method

Technical Data

Material composition	Q235B or better steel
Surface finish	Hot-dip galvanized - for outdoor use

MT-FA-G OC Box Profile U-bolt Fixation Angle - Outdoor

Order Designation	Technical Data	Sales pack quantity	Item number	
MT-FA-G M10 3/8 OC	Outdoor, low to moderate pollution (C3 / C4 - low)	10 pc	2273681	
MT-FA-G M12 1/2 OC		10 pc	2273682	
MT-FA-G M16 5/8 OC		10 pc	2273683	
MT-FA-G M22 7/8 OC		10 pc	2273684	
MT-FA-G M24 1 OC		10 pc	2273685	

MT Media Fixation for Box Profiles

U-bolt Fixation Angle - Outdoor

Operation Instruction

MT-FA-G OC

2294696-07.2020

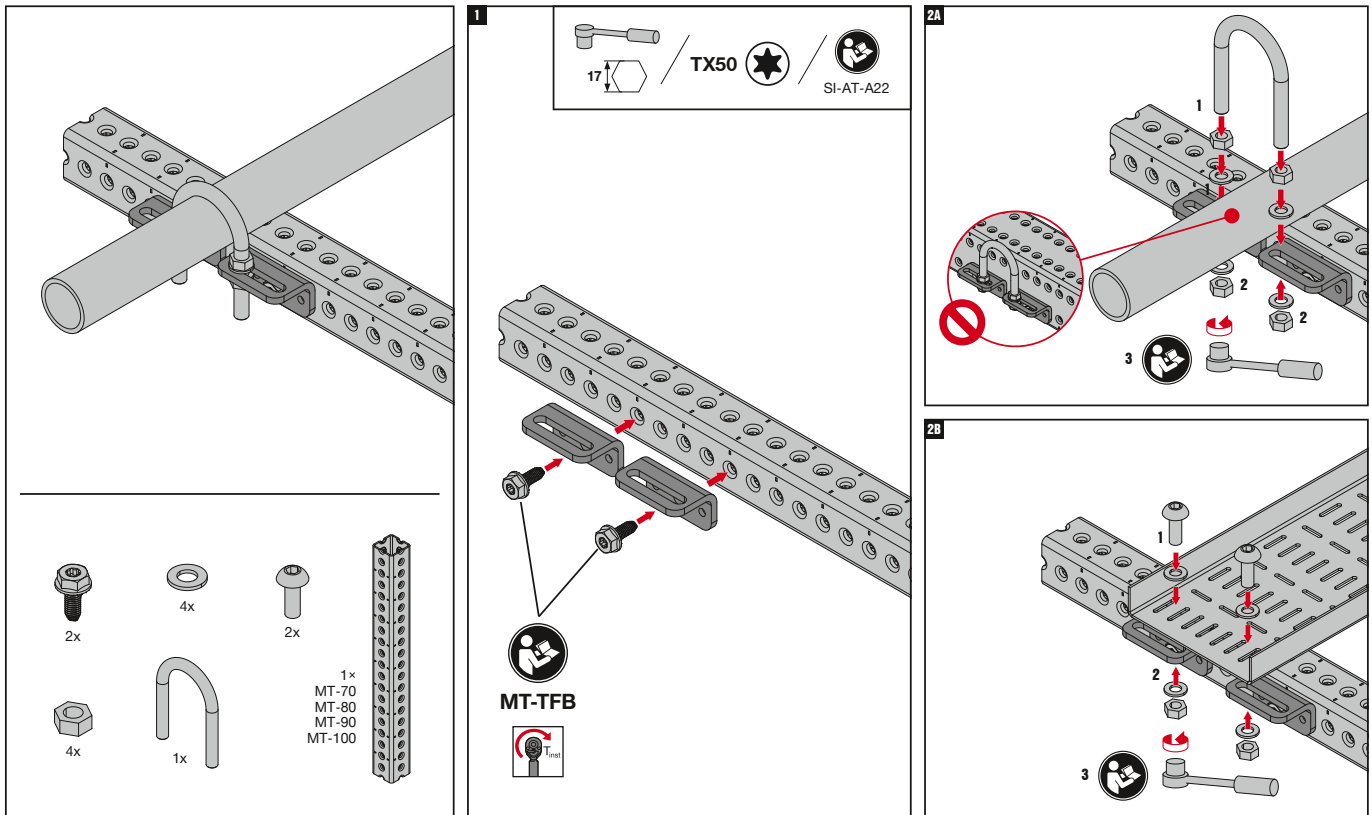

The latest IFU (Instruction for Use) is available on Hilti Online. Please check for any revisions before installing the product.

MT Media Fixation for Box Profiles

Sliding Axial Guide Pipe Shoe Fixation - Outdoor

6

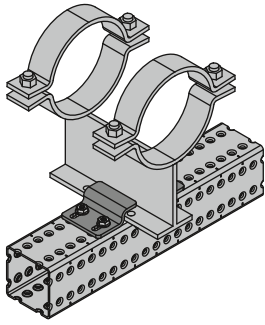

Applications

- Fastening MP-PS pipe shoes to MT Box Profiles restricting the movement to an axial sliding
- Recommended for use in Indoor or Outdoor with low to moderate pollution (C3)

Advantages

- Easier to install – slotted anchor holes to simplify pipe shoe positioning and fastening
- Adaptable – suitable for any size and configuration of Hilti MP pipe shoe
- Safer jobsites – avoid welding and drilling

Technical Data

Material composition	S280GD+ZM300
Surface finish	Outdoor Coated - ZM

MT-FPS-SF / SZ1 / SZ2 OC Sliding Axial Guide Pipe Shoe Fixation - Outdoor

Order Designation	Weight	Technical Data	Sales pack quantity	Item number	
MT-FPS-SF OC	0,27 kg	Outdoor, low to moderate pollution (C3 / C4 - low)	8 pc	2330920	
MT-FPS-SZ1 OC	0,18 kg		12 pc	2331078	
MT-FPS-SZ2 OC	0,26 kg		10 pc	2331079	

MT Media Fixation for Box Profiles

Sliding Axial Guide Pipe Shoe Fixation - Outdoor

Operation Instruction

MT-FPS-GS OC / MT-FPS-GL OC

2334620-03.2022

1

	MT-TFB	MT-TFB	MT-TFB	MT-TLB
	MT-70 / MT-80 S	MT-80 / MT-90	MT-100	MT-U-GL1
MT-FPS-SF	A-D	A-D	A-D*	A
MT-FPS-GF	A	A	A*	A

	MT-FPS-GF OC	
MP-PS 1-1	ok	ok
MP-PS 2-2	ok	ok
MP-PS L4-2	-	ok
MP-PS M4-2	-	ok
MP-PS H4-2	ok	ok

*without 1-1

2A

#		MT-FPS-SF / MT-FPS GF
MP-PS x1 - 1x	4	2 pcs
MP-PS x2 - 2x	4	2 pcs
MP-PS x4 - 2x	8	4 pcs

2B

MT-U-GL1	#	#
MP-PS x1-1x	4	8
MP-PS x2-2x	4	8
MP-PS x4-2x	-	-

MT-U-GL1					
	MT-TLB OC	M10-SL OC	A 10.5/20-F	17	20 Nm (14.75 ft-lb)
	M10x25-F	M10-F	A 10.5/20-F	17	20 Nm (14.75 ft-lb)

3

4

The latest IFU (Instruction for Use) is available on Hilti Online. Please check for any revisions before installing the product.

MT Media Fixation for Box Profiles

Plain Guide Allowing Uplift Pipe Shoe Fixation - Outdoor

6

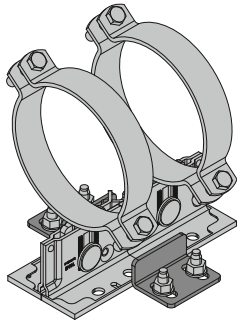

Applications

- Fastening MP-PS pipe shoes to MT Box Profiles restricting the movement to axial sliding and vertical lifting
- Recommended for use in Indoor or Outdoor with low to moderate pollution (C3)

Advantages

- Easier to install – slotted anchor holes to simplify pipe shoe positioning and fastening
- Adaptable – suitable for any size of Hilti MP pipe shoe in stand-up configuration
- Safer jobsites – avoid welding and drilling

Technical Data

Material composition	S280GD+ZM300
Surface finish	Outdoor Coated - ZM

MT-FPS-GF / GL1 / GL2 OC Plain Guide Allowing Uplift Pipe Shoe Fixation - Outdoor

Order Designation	Weight	Technical Data	Sales pack quantity	Item number	
MT-FPS-GF OC	0,30 kg	Outdoor, low to moderate pollution (C3 / C4 - low)	8 pc	2330921	
MT-FPS-GL1 OC	0,18 kg		12 pc	2331080	
MT-FPS-GL2 OC	0,26 kg		10 pc	2331081	

MT Media Fixation for Box Profiles

Plain Guide Allowing Uplift Pipe Shoe Fixation - Outdoor

Operation Instruction

MT-FPS SZx OC SET / MT-FPS GLx OC SET

2334219-08.2021

1

2A

	MT-TFB	MT-TFB	MT-TFB	MT-TLB	X-BT / F-BT	HST3 / KB-TZ2
	MT-70 / MT-80 S	MT-80 / MT-90	MT-100	MT-U-GL1		
MT-FPS-SZ1	A-D	-	-	-	A-D	A-D
MT-FPS-SZ2	-	A-D	A-D	A	A-D	A-D
MT-FPS-GL1	A	-	-	-	-	-
MT-FPS-GL2	-	A	A	A	A	A

MT-FPS-GL1 MT-FPS-GL2
 MT-FPS-SZ1 MT-FPS-SZ2

2B

	MT-U-GL1	MP-PS x1-1x	MP-PS x2-2x	MP-PS x4-2x
		4	8	-

	MT-TLB OC	M10-SL OCA	10.5/20-F	17	20 Nm (14.75 ft-lb)
MT-U-GL1	M10x25-F	M10-F	A 10.5/20-F	17	20 Nm (14.75 ft-lb)

2C

	X-BT / F-BT	
	MP-PS x1-1x	4
	MP-PS x2-2x	4
	MP-PS x4-2x	4

X-BT MR M10/ W10
 F-BT MR M10/ 3/8"

min. 20 Nm (14.75 ft-lb)

2D

	HST3-M12 / KB-TZ2 1/2"	
	MP-PS x1-1x	4
	MP-PS x2-2x	4
	MP-PS x4-2x	4

HST3-M12
 HST3-R M12
 KB-TZ2 1/2"
 KB-TZ2 1/2" SS304
 KB-TZ2 1/2" SS316

3

$\leq 2\text{mm} / 5/64"$

	MT-FPS SZx / MT-FPS-GLx	
	MP-PS x1-1x	2 pcs
	MP-PS x2-2x	2 pcs
	MP-PS x4-2x	2 pcs

4

2334219-08.2021

The latest IFU (Instruction for Use) is available on Hilti Online. Please check for any revisions before installing the product.

MT Media Fixation for Box Profiles

Plain Guide Allowing Uplift Pipe Shoe Fixation - Outdoor

Operation Instruction

MT-FPS SF OC SET / MT-FPS GF OC SET

2334620-03.2022

1

	MT-TFB	MT-TFB	MT-TFB	MT-TLB
	MT-70 / MT-80 S	MT-80 / MT-90	MT-100	MT-U-GL1
MT-FPS-SF	A-D	A-D	A-D*	A
MT-FPS-GF	A	A	A*	A

	MT-FPS-GF OC	
MP-PS 1-1	ok	ok
MP-PS 2-2	ok	ok
MP-PS L4-2	-	ok
MP-PS M4-2	ok	ok
MP-PS H4-2	ok	ok

*without 1-1

2A

#		MT-FPS-SF / MT-FPS-GF
MP-PS x1 - 1x	4	2 pcs
MP-PS x2 - 2x	4	2 pcs
MP-PS x4 - 2x	8	4 pcs

2B

	MT-U-GL1	
MP-PS x1-1x	4	8
MP-PS x2-2x	4	8
MP-PS x4-2x	-	-

	MT-TLB OC	M10-SL OC	A 10.5/20-F	17	20 Nm (14.75 ft-lb)
MT-U-GL1	M10x25-F	M10-F	A 10.5/20-F	17	20 Nm (14.75 ft-lb)

4

The latest IFU (Instruction for Use) is available on Hilti Online. Please check for any revisions before installing the product.

MT Media Fixation for Box Profiles
Fixed point Pipe Shoe Fixation - Outdoor



Applications

- Installing fixed points with MP-PS pipe shoes on Hilti MT modular Box Profiles
- Recommended for use in Indoor or Outdoor with low to moderate pollution (C3)

Advantages

- One-step installation – easy and quick fastening using Hilti MT thread-forming bolts
- Simpler method – suitable for single pipe clamp pipe shoes in combination with 100 or 150mm wide MT modular Box Profiles
- Safer jobsites – avoid welding and drilling

Technical Data

Material composition	S235JR - Yield280
Surface finish	Outdoor Coated - HDG

MT-FPS-FZL OC Fixed Point Pipe Shoe Fixation - Outdoor

Order Designation	Weight	Technical Data	Sales pack quantity	Item number	
MT-FPS-FZL OC	0,60 kg	Outdoor, low to moderate pollution (C3 / C4 - low)	2 pc	2331077	

MT Media Fixation for Box Profiles

Fixed point Pipe Shoe Fixation - Outdoor

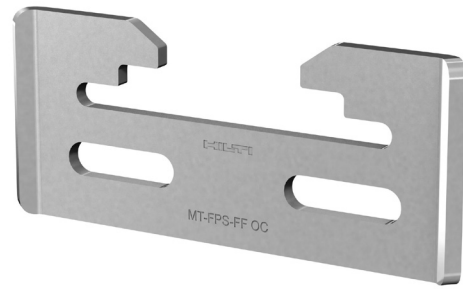
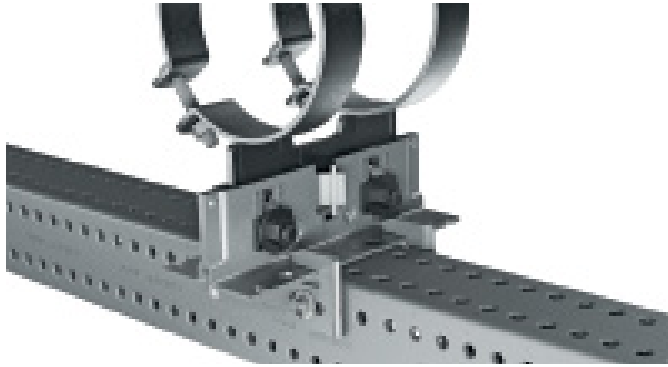

Applications

- Installing fixed points with MP-PS pipe shoes on Hilti MT modular Box Profiles
- Recommended for use in Indoor or Outdoor with low to moderate pollution (C3)

Technical Data

Material composition	S280GD+ZM300
Surface finish	Outdoor Coated - ZM

Advantages

- One-step installation – quicker and easier fastening using Hilti MT thread-forming bolts
- Simpler method – suitable for all double pipe clamp pipe shoes in combination with all available MT modular Box Profiles
- Safer jobsites – avoid welding and drilling

MT-FPS-FF OC Fixed Point Pipe Shoe Fixation - Outdoor

Order Designation	Weight	Technical Data	Sales pack quantity	Item number	
MT-FPS-FF OC	0,27 kg	Outdoor, low to moderate pollution (C3 / C4 - low)	8 pc	2331076	

MT Media Fixation for Box Profiles

Fixed point Pipe Shoe Fixation - Outdoor

Operation Instruction

MT-FPS FZL OC / MT-FPS FF OC SET

2334481-08.2021

1

	MT-70 / MT-80 S	MT-80 / MT-90 / MT-100 S	MT-100
MP-PS x1-1x	2x MT-FPS FF OC	1x MT-FPS FZL OC	1x MT-FPS FZL OC
MP-PS x2-2x	2x MT-FPS FF OC	2x MT-FPS FF OC	2x MT-FPS FF OC + 4x A 10.5x30-F
MP-PS x4-2x	-	4x MT-FPS FF OC	4x MT-FPS FF OC + 8x A 10.5x30-F

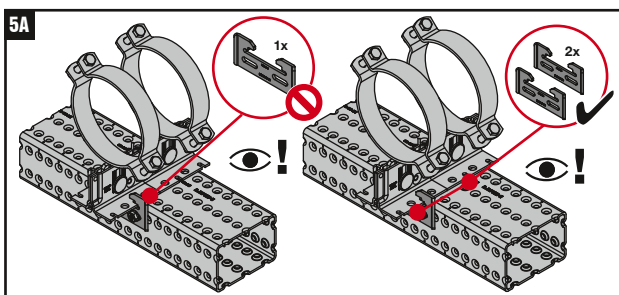
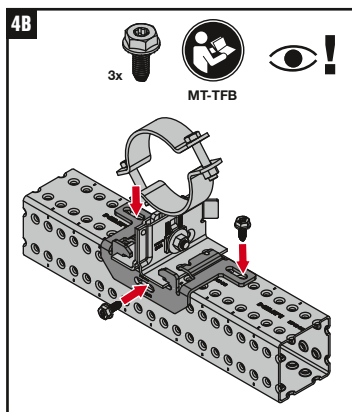
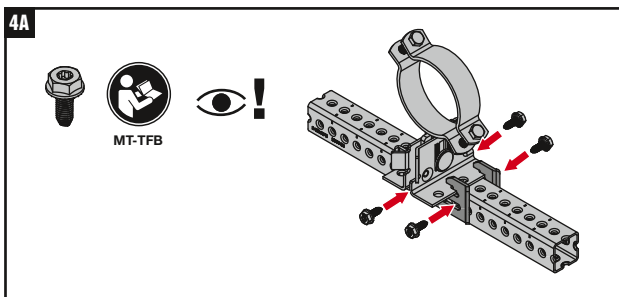
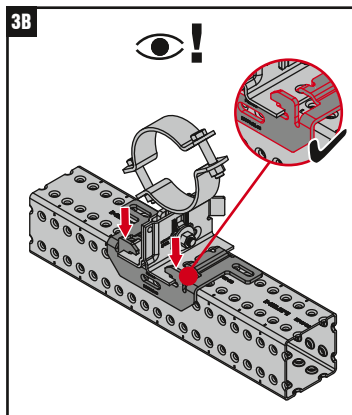
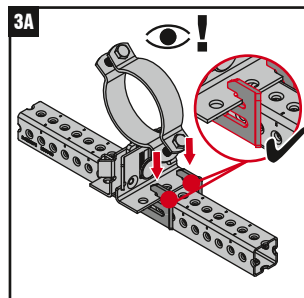
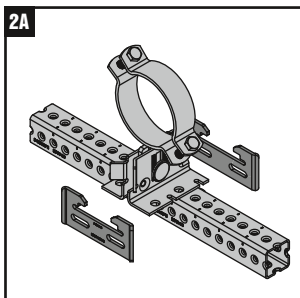
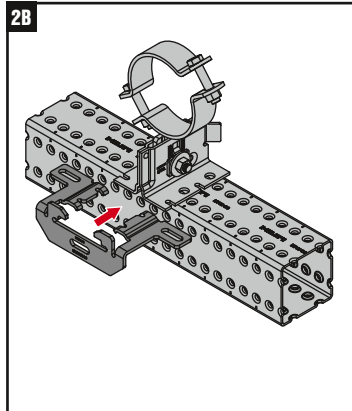

The latest IFU (Instruction for Use) is available on Hilti Online. Please check for any revisions before installing the product.

MT Media Fixation for Box Profiles

Pipe Connection plate - Outdoor

6

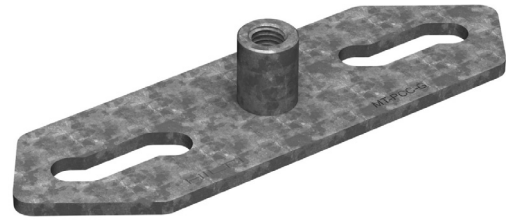
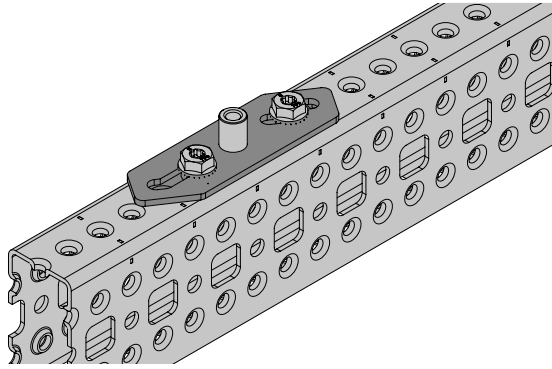

Applications

- Connecting pipe clamps directly to MT-70, MT-80, MT-90 and MT-100 Box Profiles
- Mounting medium/heavy-load pipes on Trapeze
- Mounting medium/heavy-load pipes on wall Brackets

Advantages

- Faster pipe clamp installation – attach a pipe clamp using just two thread forming bolts and an impact wrench with the Adaptive Torque module
- Full adjustability – easily install pipe clamps in the right position from M8 to M16
- Corrosion resistance – hot-dip galvanized to help protect against moisture and chemical corrosion

Technical Data

Material composition	Q355 or better steel
Surface finish	Outdoor Coated - HDG

MT-PCC-G M8/M10 / M12 / M16 OC Pipe Connection plate - Outdoor

Order Designation	Weight	Technical Data	Sales pack quantity	Item number
MT-PCC-G M8/M10 OC	134 g	Outdoor, low to moderate pollution (C3 / C4 - low)	10 pc	2353801
MT-PCC-G M12 OC	189 g		10 pc	2354564
MT-PCC-G M16 OC	152 g		10 pc	2354155

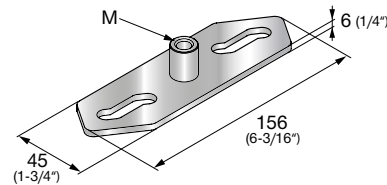

MT Media Fixation for Box Profiles

Pipe Connection plate - Outdoor

Operation Instruction

MT-PCC-G OC

2359997-03.2022

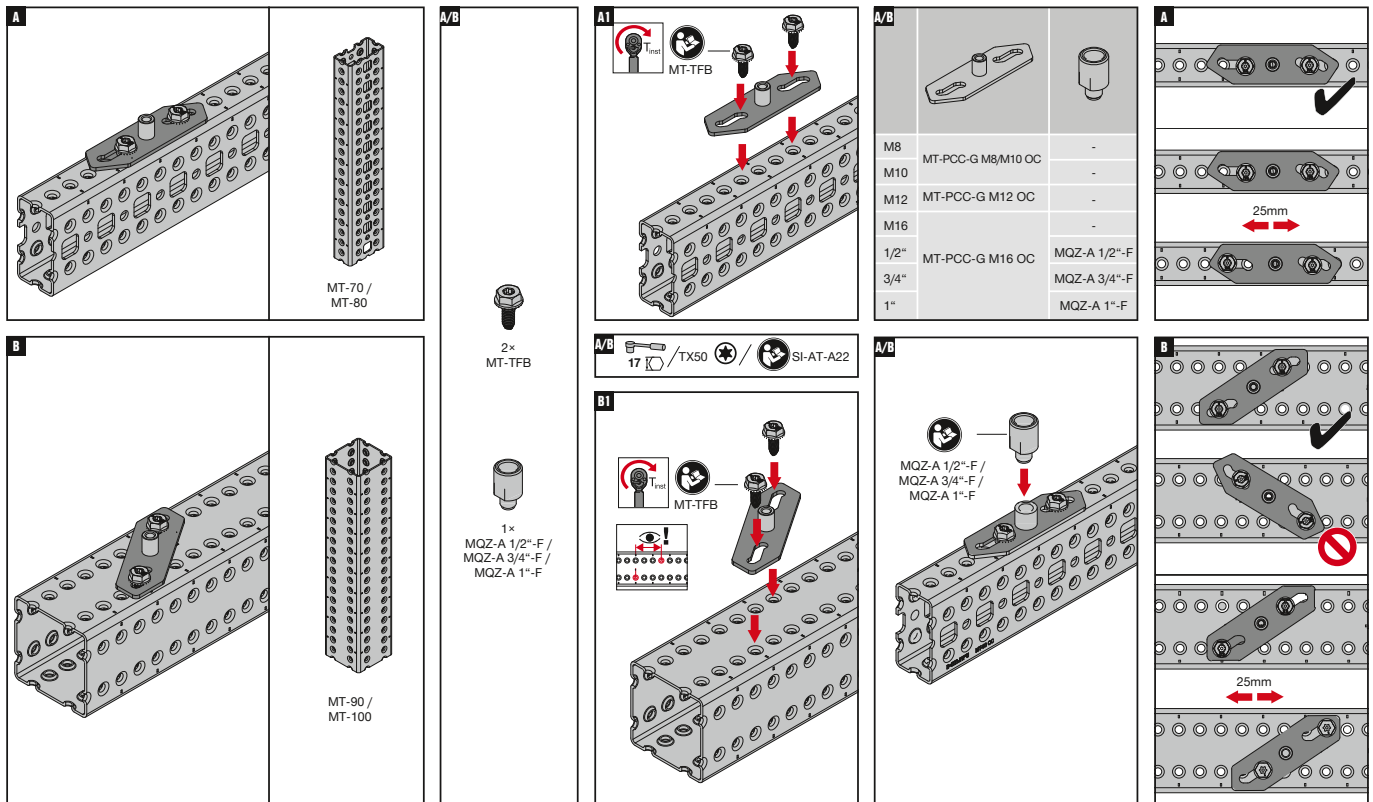

The latest IFU (Instruction for Use) is available on Hilti Online. Please check for any revisions before installing the product.

Technical Data Pipe Connection plate

Item image	Load drawing	Order Designation	+ Fx	- Fx	+ Fy	- Fy	+ Fz	- Fz
		MT-PCC-G M8/ M10 OC	1,43 kN	1,43 kN	1,43 kN	1,43 kN	7,14 kN	7,14 kN
		MT-PCC-G M12 OC	1,43 kN	1,43 kN	1,43 kN	1,43 kN	8,07 kN	8,07 kN
		MT-PCC-G M16 OC	1,43 kN	1,43 kN	1,43 kN	1,43 kN	12,36 kN	12,36 kN

Design notes

- Shown load values are recommended values with partial safety factors for actions and resistance included
- Design value = 1.4 * recommended value
- The design resistance of the products is defined in accordance with EN1993

7. MT Miscellaneous

MT Beam Clamps

beam Clamp Connections To Steel - Outdoor

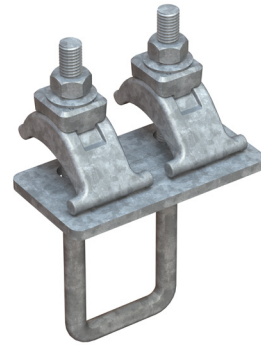
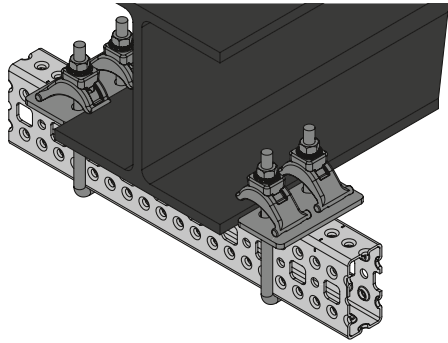

Applications

- Mounting MT-70 and MT-80 girders on structural steel
- Suitable for use in moderately corrosive environments

Technical Data

Material composition	Q235 or better steel
Surface finish	Outdoor Coated - HDG

Advantages

- Part of the Hilti MT system – an economical, all-in-one solution for virtually all modular MEP support structures
- No drilling or hot works – fasten modular girders to structural steel without anchoring or welding
- Extensive software support – PROFIS Modular Support Engineering, the MEP Support Selector, Revit® families, and plug-ins for Staad Pro® and Smart 3D® are all available to streamline design and ordering

MT-BC-GS T OC beam Clamp - Outdoor

Order Designation	Weight	Technical Data	Sales pack quantity	Item number	
MT-BC-GS T OC	1275 g	Outdoor, low to moderate pollution (C3 / C4 - low)	12 pc	2273587	

MT-BC-GXL T OC beam Clamp - Outdoor

Order Designation	Weight	Technical Data	Sales pack quantity	Item number	
MT-BC-GXL T OC	2116 g	Outdoor, low to moderate pollution (C3 / C4 - low)	10 pc	2273589	

MT Beam Clamps

beam Clamp Connections To Steel - Outdoor

7

Technical Data beam Clamp

Item image	Load drawing	Order Designation	+ Fz	- Fz	± Fx	± Fy
		MT-BC-GS T	15,0 kN	15,0 kN	3,6 kN	2,5 kN
		MT-BC-GXL T	30,0 kN	30,0 kN	5,0 kN	6,0 kN

Design notes

- Shown load values are recommended values with partial safety factors for actions and resistance included
- Design value = 1.5 * recommended value
- The design resistance of the products is defined in accordance with EN1993
- Load values are only valid per pair.

Operation Instruction

MT-BC-GS T OC / MT-BC-GXL T OC

2298185-09.2020

MT-70	MT-BC-GS T
MT-80	MT-BC-GS T
MT-90	MT-BC-GXL T
MT-100	MT-BC-GXL T

1

2

3

4

MT-BC-GS T	MT-70 MT-80	40Nm (30 ft-lb) 40Nm (30 ft-lb)
MT-BC-GXL T	MT-90 MT-100	100Nm (73 ft-lb) 120Nm (82 ft-lb)

The latest IFU (Instruction for Use) is available on Hilti Online. Please check for any revisions before installing the product.

MT Profile End Caps

Open C-Channels

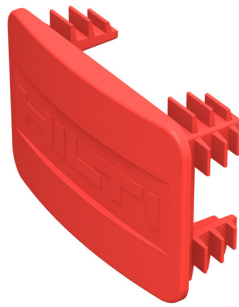

Applications

- Protecting strut Channel edges from damage during storage and transport
- Covering any sharp edges left after cutting to size

Advantages

- Part of the Hilti MT system – an economical, all-in-one solution for virtually all modular MEP support structures
- Safer handling – protects installers from sharp edges which may be left after cutting the strut Channel
- Improved durability – helps to prevent deformed edges during storage and transport around the construction site

Technical Data

Material composition	PPB-M02
Surface finish	n/a

MT-EC-20 Channel End Cap

Order Designation	Weight	Sales pack quantity	Item number	
MT-EC-20	3 g	50 pc	2282197	

MT-EC-30 Channel End Cap

Order Designation	Weight	Sales pack quantity	Item number	
MT-EC-30	4 g	50 pc	2273642	

MT Profile End Caps

Open C-Channels

MT-EC-40/50 Channel End Cap

Order Designation	Weight	Sales pack quantity	Item number	
MT-EC-40/50	6 g	50 pc	2273643	

MT-EC-60 Channel End Cap

Order Designation	Weight	Sales pack quantity	Item number	
MT-EC-60	9 g	50 pc	2273644	

MT Profile End Caps

Box Profiles

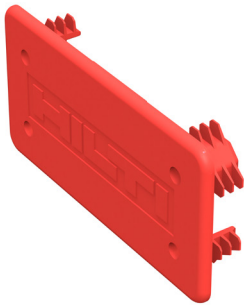

Applications

- Protecting MT-Box Profile edges from damage during storage and transport
- Covering any sharp edges left after cutting to size

Advantages

- Part of the Hilti MT system – an economical, all-in-one solution for virtually all modular MEP support structures
- Safer handling – protects installers from sharp edges which may be left after cutting the strut Channel
- Improved durability – helps to prevent deformed edges during storage and transport around the construction site

Technical Data

Material composition	PPB-M02
Surface finish	n/a

MT-EC-70 Box Profile End Cap

Order Designation	Weight	Sales pack quantity	Item number	
MT-EC-70	8 g	50 pc	2273697	

MT-EC-80 Box Profile End Cap

Order Designation	Weight	Sales pack quantity	Item number	
MT-EC-80	17 g	25 pc	2273698	

MT Profile End Caps

Box Profiles

MT-EC-90 Box Profile End Cap

Order designation	Weight	Sales pack Quantity	Item number	
MT-EC-90	31 g	25 pc	2273699	

MT-EC-100 Box Profile End Cap

Order designation	Weight	Sales pack Quantity	Item number	
MT-EC-100	45 g	25 pc	2273700	

MT Profile Rubber Inlays Open C-Channels

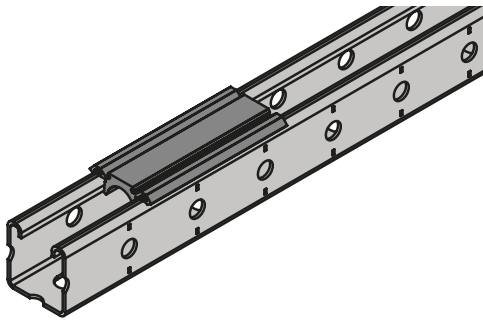

Applications

- Acoustic insulation of heating, ventilation, and air conditioning installations, such as rectangular air ducts

Advantages

- Improve acoustic insulation of HVAC installations – these inlays can deliver a significant noise reduction
- Easy to install – simply click into MT strut Channels, no additional fasteners required. Can also be installed from the back of the Open Channels

Technical Data

Material composition	EPDM
Surface finish	n/a

MT-RI Rubber Inlay

Order Designation	Weight	Sales pack quantity	Item number	
MT-RI 20 m	6924 g	1 pc	2337452	
MT-RI 10 cm	35 g	100 pc	2337453	
MT-RI 2 cm	7 g	100 pc	2337454	

MT Profile Rubber Inlays

Open C-Channels

Operation Instruction

MT-RI

2348181-12.2021

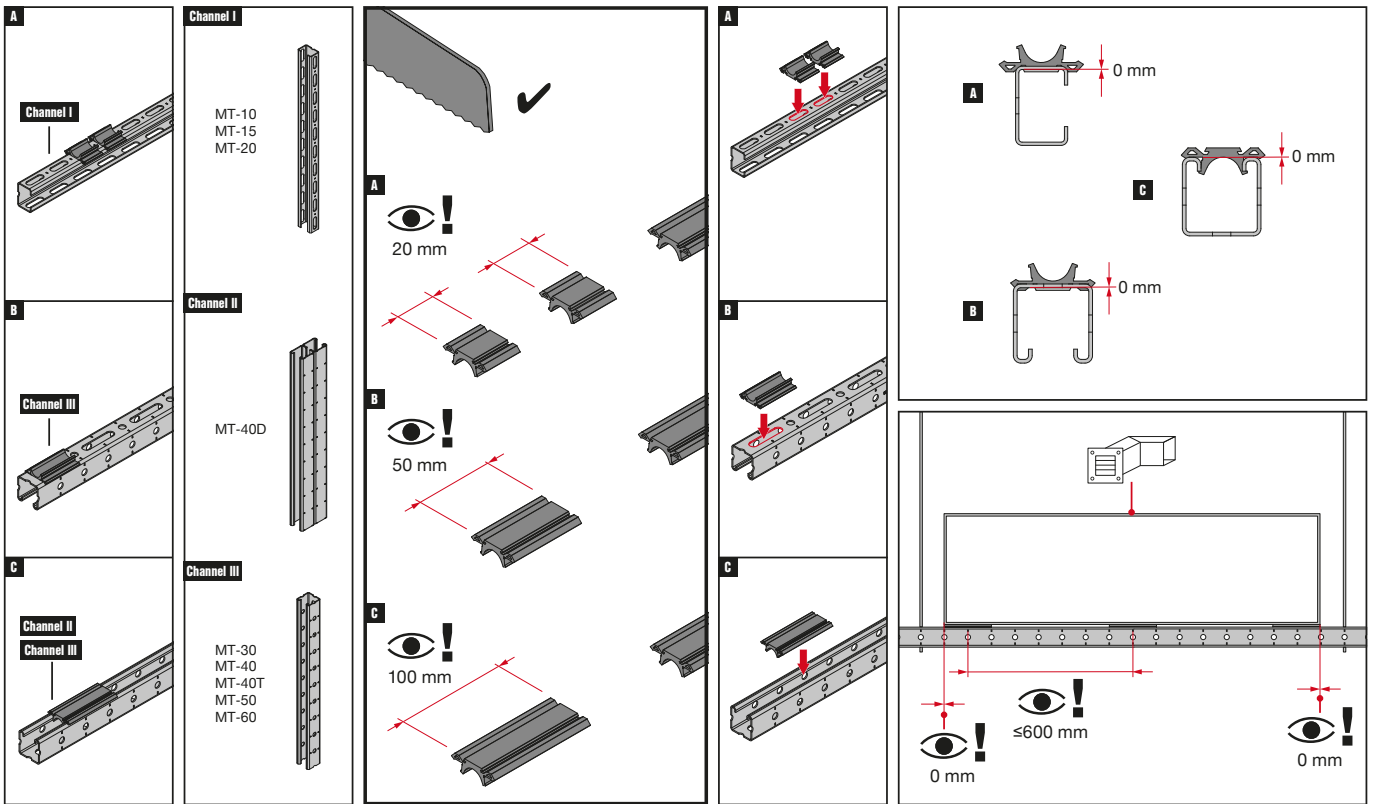

The latest IFU (Instruction for Use) is available on Hilti Online. Please check for any revisions before installing the product.

8. MT Rooftop Application portfolio

8

MT-B-LDP S Load distribution plate

Small load distribution plate for installing ventilation ducts, pipework or cable trays on flat roofs



Applications

- Installing ventilation ducts, pipework and cable trays on flat roofs
- Suitable for use in outdoor environments

Technical Data

Material composition	Aluminium, Recycled Rubber blend SBR-PU-EPDM
Surface finish	n/a

Advantages

- Part of the Hilti MT system – an economical, all-in-one solution for rooftop ventilation and other modular support systems
- Easier to handle and transport compared to pre-fabricated welded steel
- Includes a rubber inlay – made from UV-resistant and recycled rubber to help protect the roof membrane
- Suitable for outdoor Applications, with features such as aluminum feet for better weather resistance

MT-B-LDP S Load distribution plate

Order Designation	Technical Data	Weight	Sales pack quantity	Item number	
MT-B-LDP S	Outdoor, low to moderate pollution (C3 / C4 - low)	397 g/pc	4 pcs	2464345	<p>Technical drawing showing dimensions of the MT-B-LDP S load distribution plate:</p> <ul style="list-style-type: none"> Top width: 7.5 (5/16") Top flange width: 22.3 (7/8") Top flange height: 2.75 (1/8") Bottom flange width: 80 (3-3/16") Bottom flange height: 9.4 (3-11/16") Bottom flange thickness: 5 (3/16") Length: 250 (9-7/8") Overall length: 265 (10-7/16") Height: 24 (15/16")

MT-B-LDP ME Load distribution plate

Medium load distribution plate for installing ventilation ducts and ventilation equipment on flat roofs

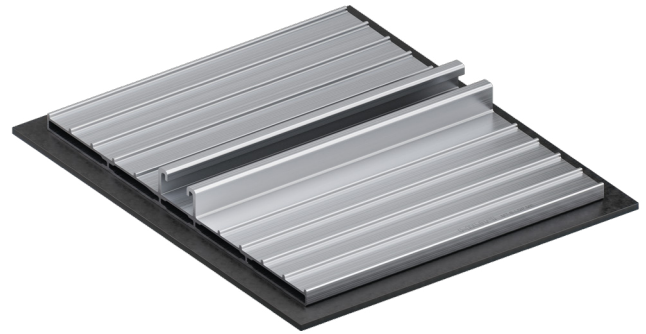

Applications

- Installing ventilation equipment, ducts, pipework, cable trays on flat roofs
- Suitable for use in outdoor environments

Technical Data

Material composition	Aluminium, Recycled Rubber blend SBR-PU-EPDM
Surface finish	n/a

Advantages

- Part of the Hilti MT system – an economical, all-in-one solution for rooftop ventilation and other modular support systems
- Easier to handle and transport compared to pre-fabricated welded steel
- Includes a rubber inlay – made from UV-resistant and recycled rubber to help protect the roof membrane
- Suitable for outdoor Applications, with features such as aluminum feet for better weather resistance

MT-B-LDP ME Load distribution plate

Order Designation	Technical Data	Weight	Sales pack quantity	Item number	
MT-B-LDP ME	Outdoor, low to moderate pollution (C3 / C4 - low)	1,576 g/pc	4 pcs	2464382	<p>Technical drawing showing dimensions (mm and inches):</p> <ul style="list-style-type: none"> Top edge: 36 (1-27/64) Right edge: 128.5 (5-1/16) Bottom edge: 284 (11-3/16) Left edge: 334 (13-1/8) Inner width: 300 (11-13/16) Inner length: 250 (9-7/8) Height of rib: 22.3 (7/8) Width of rib: 5 (3/16) Small offset: 3 (1/8)

MT-C-LDP L1 OC Angle Connector - Outdoor

Angle Connector for assembling Channel structure or Channel with Load Distribution plate, for outdoor use with low pollution

8



Applications

- Fastening connections between two strut Channels or one Channel and Load Distribution plate
- Perfectly suitable for outdoor Applications

Advantages

- Part of the Hilti MT system – an economical, all-in-one solution for virtually all modular MEP support structures
- Vertical Channel can be inclined up to 7-degrees for compensation of roof pitch
- Connector with Channel can be inclined up to 10-degrees for compensation of roof pitch

Technical Data

Material composition	Q235 or better steel
Surface finish	Outdoor Coated - HDG

MT-C-LDP L1 OC Angle Connector - Outdoor

Order Designation	Technical Data	Weight	Sales pack quantity	Item number	
MT-C-LDP L1 OC	Outdoor, low to moderate pollution (C3 / C4 - low)	210 g/pc	8 pc	2320180	

MT-C-T 3D/2/HL OC Connector - Outdoor

3D Connector for assembling rigid Channel structures for outdoor use with low pollution

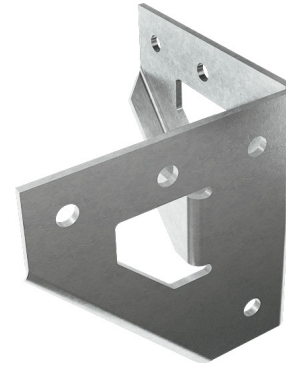

Applications

- Installing ventilation equipment, ducts, pipework and cable trays on flat roofs
- Suitable for use in outdoor environments

Technical Data

Material composition	S235JR
Surface finish	Outdoor Coated - HDG

Advantages

- Part of the Hilti MT system – an economical, all-in-one solution for virtually all modular MEP support structures
- Easy to install – compatible with the Hilti MT Twist-Lock and hexagon bolts
- Provides rigidity to free standing structures
- Allows bracing to be removed

MT-C-T 3D/2/HL Connector - Outdoor

Order Designation	Technical Data	Weight	Sales pack quantity	Item number	
MT-C-T 3D/2/HL OC	Outdoor, low to moderate pollution (C3 / C4 - low)	968 g/pc	8 pc	2320181	

MT-B-LDP S Load distribution plate

Operation instruction MT-B-LDP S

2321404-06.2021

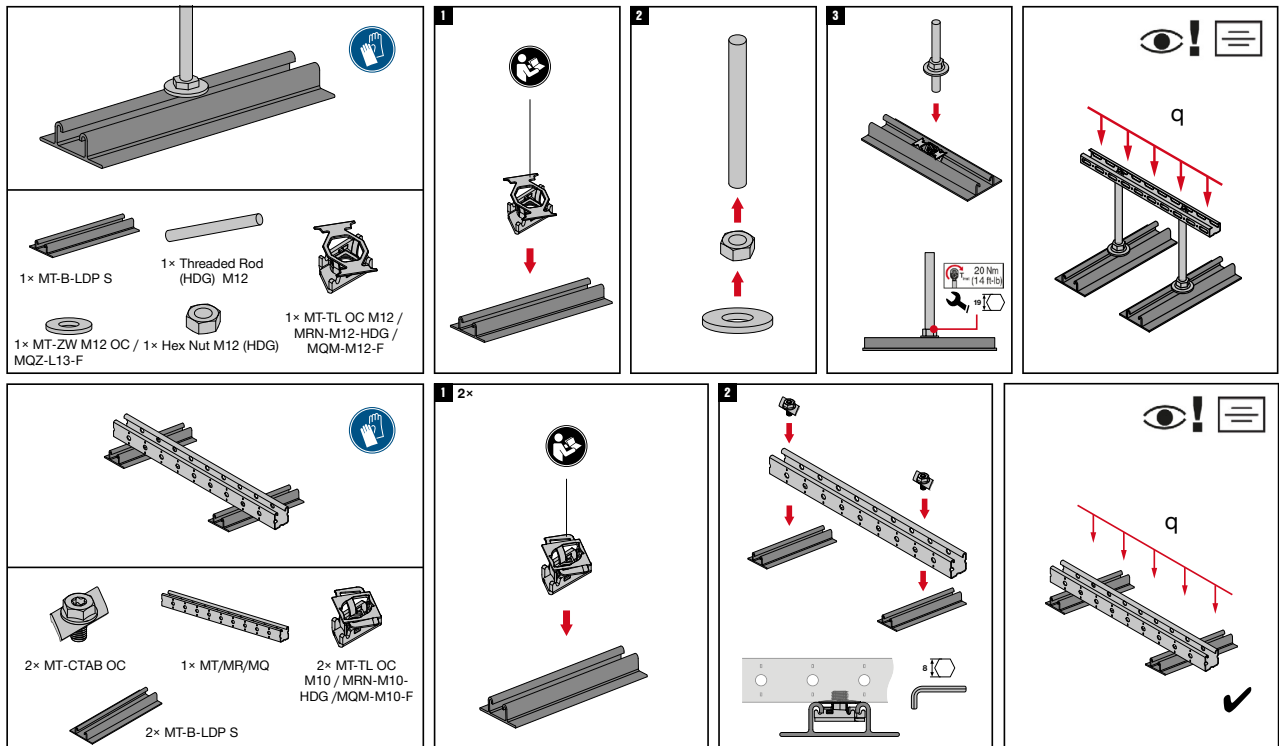

The latest IFU (Instruction for Use) is available on Hilti Online. Please check for any revisions before installing the product.

MT-B-LDP ME Load distribution plate

Operation instruction MT-B-LDP ME

2330200-06.2021

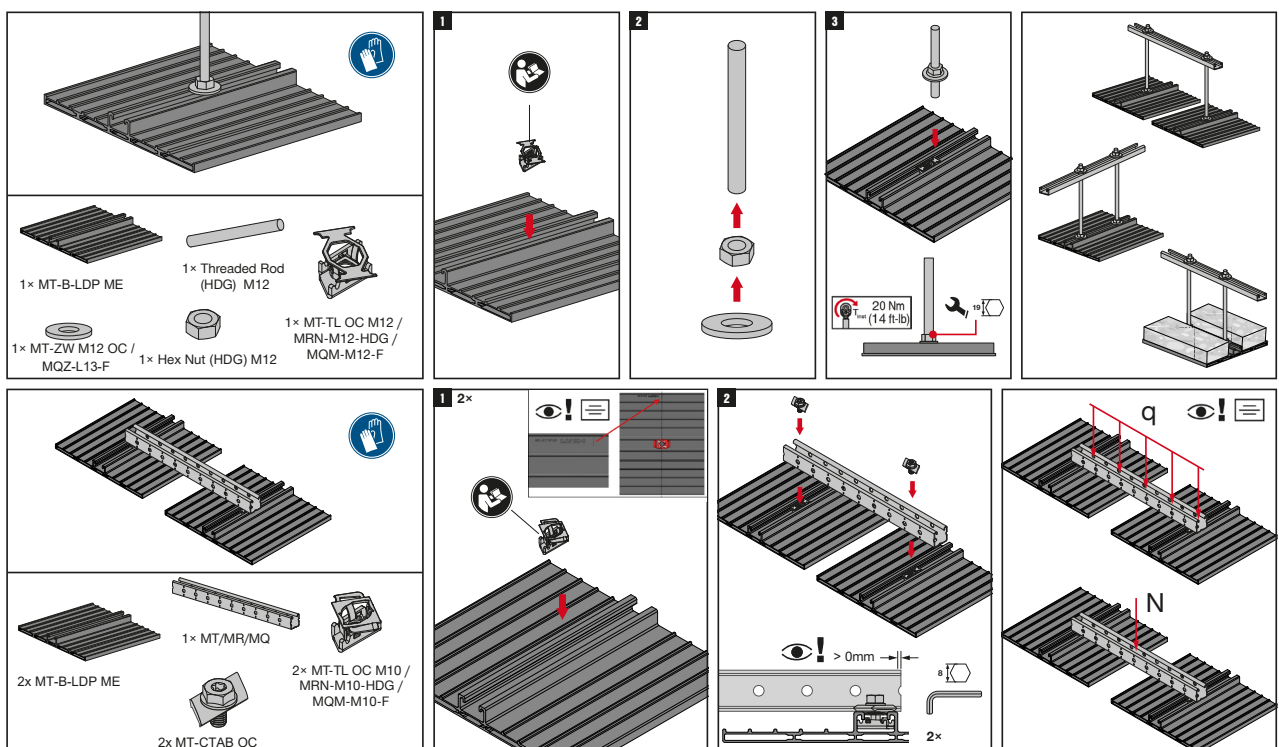

The latest IFU (Instruction for Use) is available on Hilti Online. Please check for any revisions before installing the product.

MT-C-LDP L1 OC Angle Connector - Outdoor

Operation instruction MT-C-LDP L1 OC

2321402-02.2021

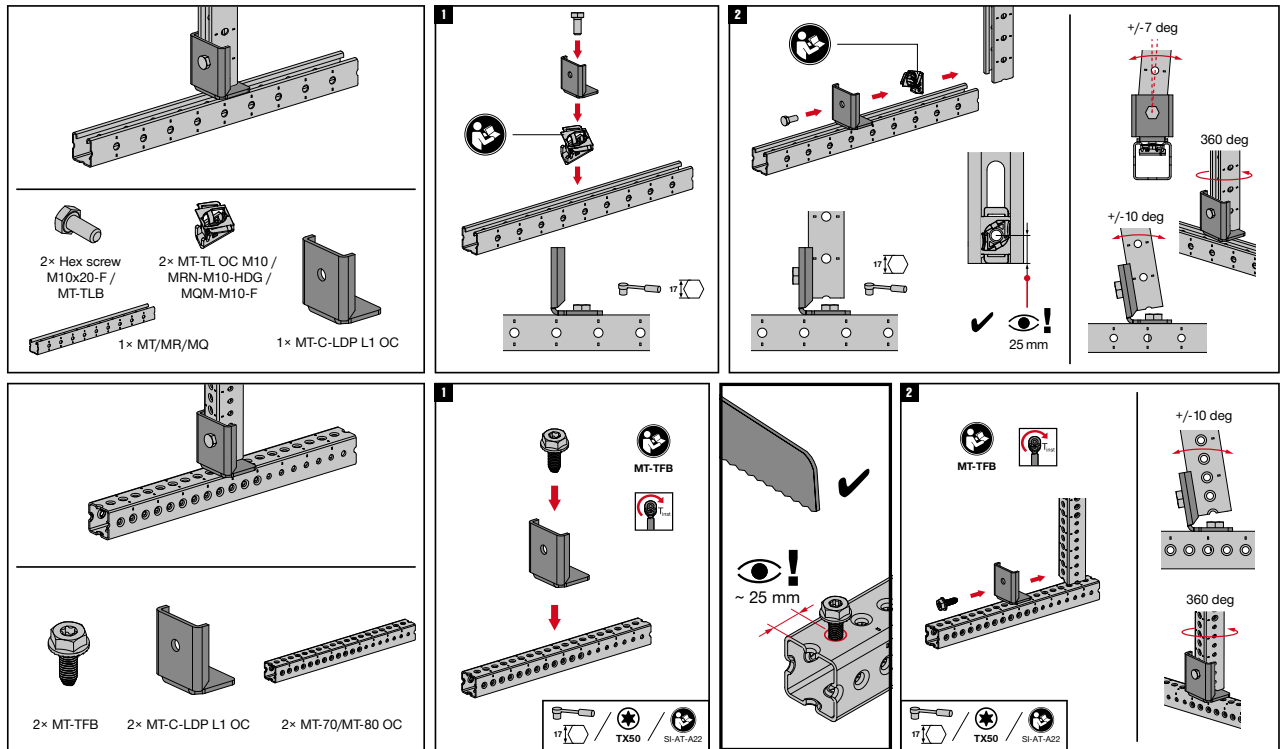

The latest IFU (Instruction for Use) is available on Hilti Online. Please check for any revisions before installing the product.

MT-C-T 3D/2/HL OC Connector - Outdoor

Operation instruction MT-C-T 3D/2/HL OC

2321403-03.2021

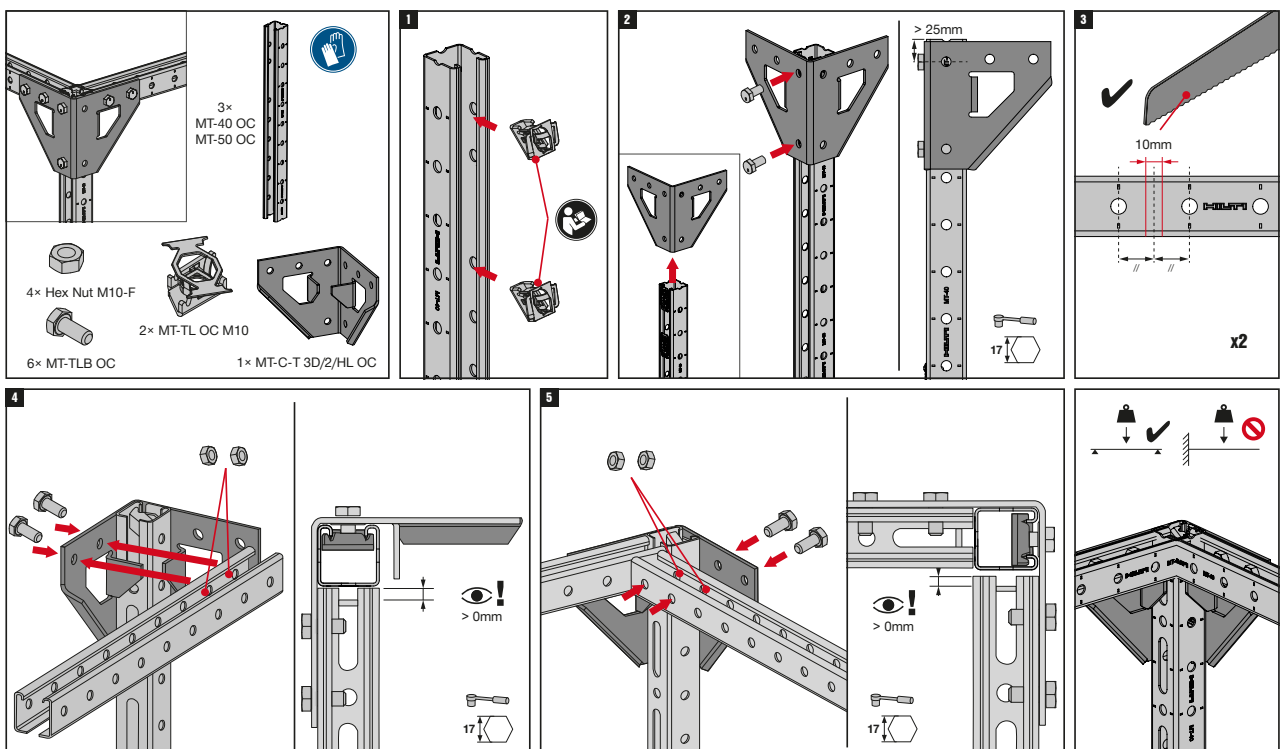

The latest IFU (Instruction for Use) is available on Hilti Online. Please check for any revisions before installing the product.

9. MT Seismic Bracing portfolio

9

MT-S-RS Rod stiffener

Pre-assembled Connector for fastening Channel around threaded rod to provide Seismic Bracing

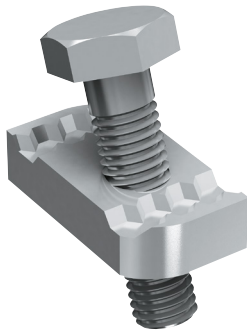

Applications

- Fixing threaded rod lengthwise within MT C-Channels
- Increasing the compressive strength of threaded rod for use as Seismic Bracing in MEP support structures
- Suitable for use in dry, indoor environments

Technical Data

Material composition	Q235 or better steel
Surface finish	Pre-galvanized - for dry indoor use only

Advantages

- Part of the Hilti MT system – an economical, all-in-one solution for virtually all modular MEP support structures
- Increasing the compressive strength of threaded rod for use as Seismic Bracing in MEP support structures
- Adaptable – unlike welding, modular rod stiffeners allow you to modify C-Channel framing for future MEP requirements

MT-S-RS Rod stiffener

Order Designation	Technical Data	Sales pack quantity	Item number	
MT-S-RS	Dry indoor conditions (C1) Indoor with temporary condensation (C2)	25 pc	2282198	

MT-S-RS OC Rod stiffener - Outdoor

Pre-assembled Connector for fastening Channel around threaded rod to provide Seismic Bracing

9

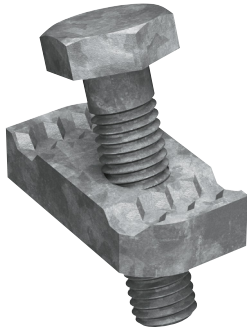

Applications

- Fixing threaded rod lengthwise within MT C-Channels
- Increasing the compressive strength of threaded rod for use as Seismic Bracing in MEP support structures
- Suitable for use in moderately corrosive environments

Advantages

- Part of the Hilti MT system – an economical, all-in-one solution for virtually all modular MEP support structures
- Increasing the compressive strength of threaded rod for use as Seismic Bracing in MEP support structures
- Adaptable – unlike welding, modular rod stiffeners allow you to modify C-Channel framing for future MEP requirements

Technical Data

Material composition	Q235 or better steel
Surface finish	Hot-dip galvanized - for outdoor use

MT-S-RS Rod stiffener

Order Designation	Technical Data	Sales pack quantity	Item number	
MT-S-RS OC	Outdoor, low to moderate pollution (C3 / C4 - low)	25 pc	2273584	

MT-S-H1 Seismic Brace Base

One-hole hinged Connector for assembling Seismic Bracing of MT C-Channel framing

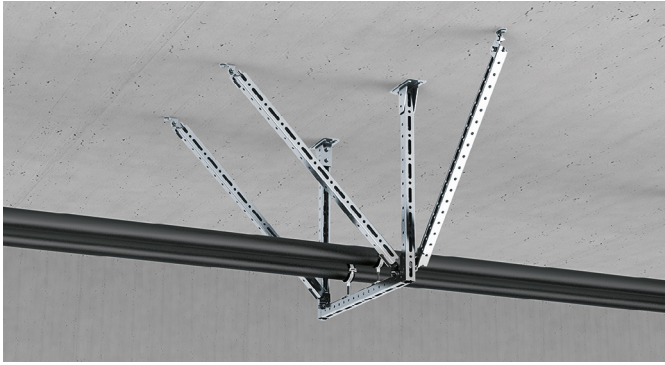

Applications

- Seismic bracing of C-Channel framing
- Anchoring C-Channel brace members to concrete for use as Seismic Bracing
- Connecting C-Channel brace members to MT-S-L seismic angle Brackets for use as Seismic Bracing
- Suitable for use in dry, indoor environments

Advantages

- Part of the Hilti MT system – an economical, all-in-one solution for virtually all modular MEP support structures
- Easy to install – pivoting joint simplifies assembly and fastening
- Engineering and calculation service available – your local Hilti Engineers can provide advice and calculation services on more complex projects

Technical Data

Material composition	Q355 or better steel
Surface finish	Pre-galvanized - for dry indoor use only

MT-S-H1 Seismic Brace Base

Order Designation	Technical Data	Anchorage hole - D	Sales pack quantity	Item number	
MT-S-H1 M10	Dry indoor conditions (C1) Indoor with temporary condensation (C2)	11,55 mm	10 pc	2273645	
MT-S-H1 M12		13,65 mm	10 pc	2273646	

MT-S-H1 OC Seismic Brace Base - Outdoor

One-hole hinged Connector for assembling Seismic Bracing of MT C-Channel framing

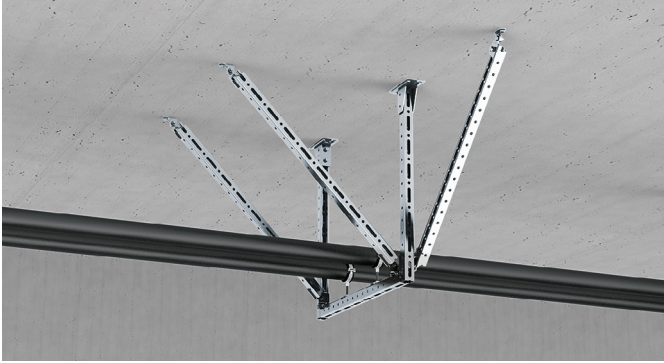

Applications

- Seismic bracing of C-Channel framing
- Anchoring C-Channel brace members to concrete for use as Seismic Bracing
- Connecting C-Channel brace members to MT-S-L seismic angle Brackets for use as Seismic Bracing
- Suitable for use in moderately corrosive environments

Technical Data

Material composition	Q355 or better steel
Surface finish	Hot-dip galvanized - for outdoor use

Advantages

- Part of the Hilti MT system – an economical, all-in-one solution for virtually all modular MEP support structures
- Easy to install – pivoting joint simplifies assembly and fastening
- Engineering and calculation service available – your local Hilti Engineers can provide advice and calculation services on more complex projects
- Corrosion resistant – hot-dip galvanized to help protect against moisture and chemical corrosion

MT-S-H1 OC Seismic Brace Base - Outdoor

Order Designation	Technical Data	Anchorage hole - D	Sales pack quantity	Item number	
MT-S-H1 M10 OC	Outdoor, low to moderate pollution (C3 / C4 - low)	11,55 mm	10 pc	2282199	
MT-S-H1 M12 OC		13,65 mm	10 pc	2282200	

MT-S-H2 Seismic Brace Base

Two-hole hinged Connector for assembling Seismic Bracing of MT C-Channel framing

9

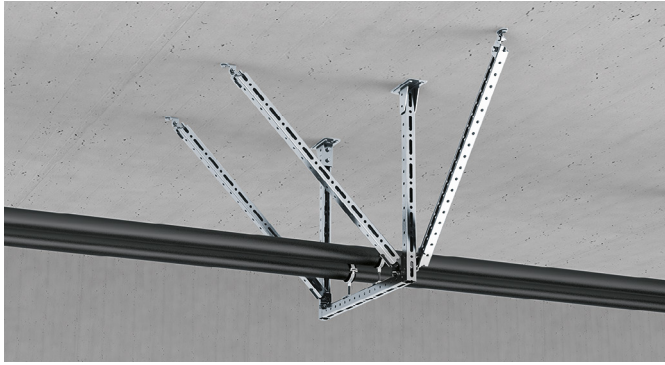

Applications

- Seismic bracing of C-Channel framing
- Anchoring C-Channel brace members to concrete for use as Seismic Bracing
- Connecting C-Channel brace members to MT-S-L seismic angle Brackets for use as Seismic Bracing
- Suitable for use in dry, indoor environments

Advantages

- Part of the Hilti MT system – an economical, all-in-one solution for virtually all modular MEP support structures
- Easy to install – pivoting joint simplifies assembly and fastening
- Engineering and calculation service available – your local Hilti Engineers can provide advice and calculation services on more complex projects

Technical Data

Material composition	Q355 or better steel
Surface finish	Pre-galvanized - for dry indoor use only

MT-S-H2 Seismic Brace Base

Order Designation	Technical Data	Anchorage hole - D	Sales pack quantity	Item number	
MT-S-H2 M10	Dry indoor conditions (C1) Indoor with temporary condensation (C2)	11,55 mm	10 pc	2273647	
MT-S-H2 M12		13,65 mm	10 pc	2273648	

MT-S-H2 OC Seismic Brace Base - Outdoor

Two-hole hinged Connector for assembling Seismic Bracing of MT C-Channel framing

9

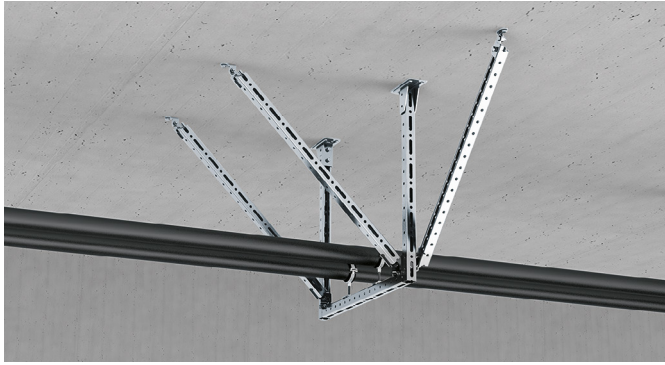

Applications

- Seismic bracing of C-Channel framing
- Anchoring C-Channel brace members to concrete for use as Seismic Bracing
- Connecting C-Channel brace members to MT-S-L seismic angle Brackets for use as Seismic Bracing
- Suitable for use in moderately corrosive environments

Technical Data

Material composition	Q355 or better steel
Surface finish	Hot-dip galvanized - for outdoor use

Advantages

- Part of the Hilti MT system – an economical, all-in-one solution for virtually all modular MEP support structures
- Easy to install – pivoting joint simplifies assembly and fastening
- Engineering and calculation service available – your local Hilti Engineers can provide advice and calculation services on more complex projects
- Corrosion resistant – hot-dip galvanized to help protect against moisture and chemical corrosion

MT-S-H2 OC Seismic Brace Base - Outdoor

Order Designation	Technical Data	Anchorage hole - D	Sales pack quantity	Item number	
MT-S-H2 M10 OC	Outdoor, low to moderate pollution (C3 / C4 - low)	11,55 mm	10 pc	2282201	
MT-S-H2 M12 OC		13,65 mm	10 pc	2282202	

MT-S-L Seismic angle Bracket

Angle Bracket for assembling braced MT C-Channel structures in seismic zones

9

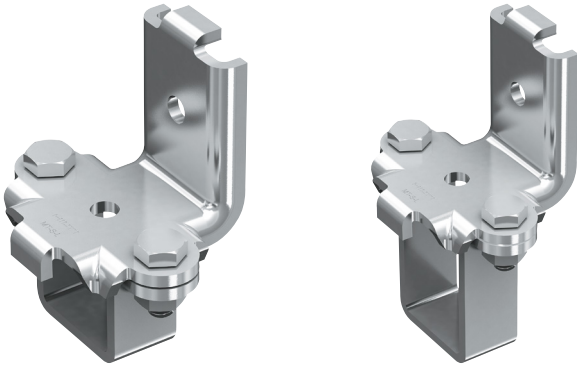

Applications

- Right-angle connections between MT-40, MT-60 C-Channels & MT-40D double C-Channels with connection to Seismic Bracing
- Assembling metal framing for MEP support structures in seismic zones
- Suitable for use in dry, indoor environments

Advantages

- Part of the Hilti MT system – an economical, all-in-one solution for virtually all modular MEP support structures
- Easy to install – compatible with the Hilti MT Twist-Lock, a faster alternative to spring nuts for assembling a modular support system
- Winged angle Connector – includes connection points to MT-S-H1 and MT-S-H2
- Adaptable – unlike welding, seismic Brackets allow you to modify C-Channel framing for future MEP requirements

Technical Data

Material composition	Q235 or better steel
Surface finish	Pre-galvanized - for dry indoor use only

MT-S-L Seismic angle Bracket

Order Designation	Technical Data	Sales pack quantity	Item number	
MT-S-L 40-50	Dry indoor conditions (C1) Indoor with temporary condensation (C2)	10 pc	2273649	
MT-S-L 60		10 pc	2273650	
MT-S-L 40D		10 pc	2273651	

MT-S-L OC Seismic angle Bracket - Outdoor

Angle Bracket for assembling braced MT C-Channel structures in seismic zones

9

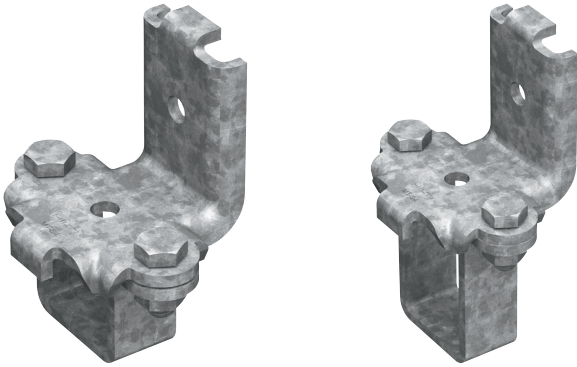

Applications

- Right-angle connections between MT-40, MT-60 C-Channels & MT-40D double C-Channels with connection to Seismic Bracing
- Assembling metal framing for MEP support structures in seismic zones
- Suitable for use in moderately corrosive environments

Advantages

- Part of the Hilti MT system – an economical, all-in-one solution for virtually all modular MEP support structures
- Easy to install – compatible with the Hilti MT Twist-Lock, a faster alternative to spring nuts for assembling a modular support system
- Adaptable – unlike welding, seismic Brackets allow you to modify C-Channel framing for future MEP requirements
- Engineering and calculation service available – your local Hilti Engineers can provide advice and calculation services on more complex projects

Technical Data

Material composition	Q235 or better steel
Surface finish	Hot-dip galvanized - for outdoor use

MT-S-L OC Seismic angle Bracket - Outdoor

Order Designation	Technical Data	Sales pack quantity	Item number	
MT-S-L 40-50 OC	Outdoor, low to moderate pollution (C3 / C4 - low)	10 pc	2282203	
MT-S-L 60 OC		10 pc	2282204	
MT-S-L 40D OC		10 pc	2282205	

MT Fast-Lock seismic hinges

One-hole hinged Connector with pre-assembled Fast-Lock nut and bolt for assembling Seismic Bracing of MT C-Channel framing

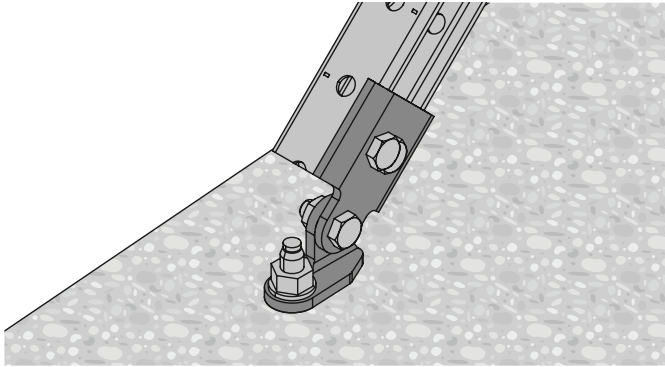

Applications

- Seismic bracing of C-Channel framing
- Anchoring C-Channel brace members to concrete for use as Seismic Bracing
- Connecting C-Channel brace members to MT-S-L seismic angle Brackets for use as Seismic Bracing
- Suitable for use in dry, indoor environments

Technical Data

Material composition	DD11 MOD
Surface finish	Indoor-coated Electro-galvanized

Advantages

- Faster installations – pre-assembled with the Hilti MT Fast-Lock, our fastest method for assembling a modular support system with fewer steps
- Simplified stock management – pre-assembly greatly reduces the total number of MT components, for easier purchasing, handling, and storage
- Consistent installation quality – pre-assembly removes additional steps, helping reduce assembly errors for safer installations
- Easy to install – pivoting joint simplifies assembly and fastening
- Part of the Hilti MT system – an economical, all-in-one solution for virtually all modular MEP support structures
- Extensive software support - PROFIS Modular Support Engineering, BIMCAD content, and Revit® families are all available to streamline design and ordering

MT-S-H1 FL Pre-assembled Seismic Hinge

Order Designation	Material composition	Technical Data	Anchorage - D	Sales pack quantity	Item number	
MT-S-H1 FL M10	Q235B	Dry indoor conditions (C1) Indoor with temporary condensation (C2)	11,55 mm	14 pc	2399662	
MT-S-H1 FL M12	Q235B	Dry indoor conditions (C1) Indoor with temporary condensation (C2)	13,65 mm	14 pc	2399663	

MT-S-L FL 40 seismic angle Bracket

Angle Bracket with pre-assembled Fast-Lock nut and bolt for assembling braced MT-40 C-Channel structures in seismic zones

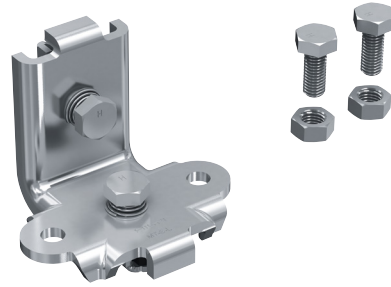
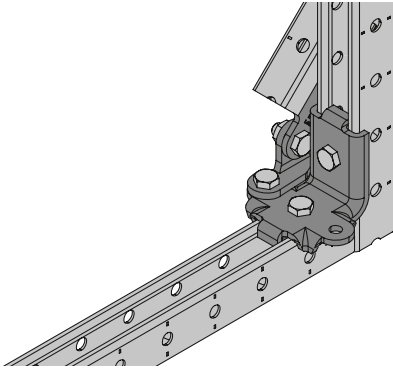

Applications

- Right-angle connections between MT-40 C-Channels with connection to Seismic Bracing
- Assembling metal framing for MEP support structures in seismic zones
- Suitable for use in dry, indoor environments

Technical Data

Material composition	DD11 MOD
Surface finish	Indoor-coated Electro-galvanized

Advantages

- Faster installations – pre-assembled with the Hilti MT Fast-Lock, our fastest method for assembling a modular support system with fewer steps
- Simplified stock management – pre-assembly greatly reduces the total number of MT components, for easier purchasing, handling, and storage
- Consistent installation quality – pre-assembly removes additional steps, helping reduce assembly errors for safer installations
- Winged angle Connector – includes connection points to MT-S-H1
- Part of the Hilti MT system – an economical, all-in-one solution for virtually all modular MEP support structures
- Extensive software support - PROFIS Modular Support Engineering, BIMCAD content, and Revit® families are all available to streamline design and ordering

MT-S-L FL Pre-assembled Seismic Angle Bracket

Order Designation	Material composition	Technical Data	Sales pack quantity	Item number	
MT-S-L FL seismic	S235JR, Q235B	Dry indoor conditions (C1) Indoor with temporary condensation (C2)	14 pc	2399664	

MT-S-RS Rod stiffener

9

Operation instruction MT-S-RS / MT-S-RS OC

2294624-08.2020

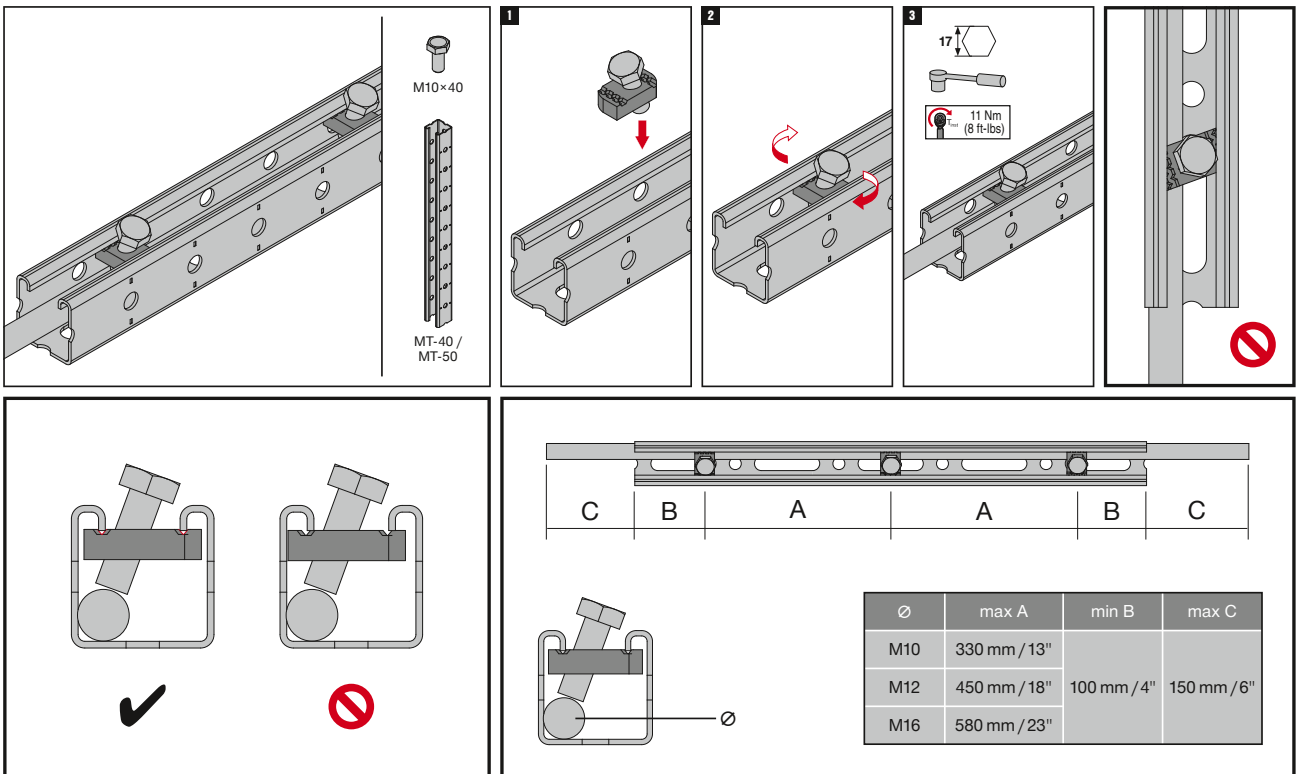

The latest IFU (Instruction for Use) is available on Hilti Online. Please check for any revisions before installing the product.

MT-S-L Seismic angle Bracket

Operation instruction

MT-S-L 40-50 / MT-S-L 60 / MT-S-L 40D
MT-S-L 40-50 OC / MT-S-L 60 OC / MT-S-L 40D OC

2294626-09.2020

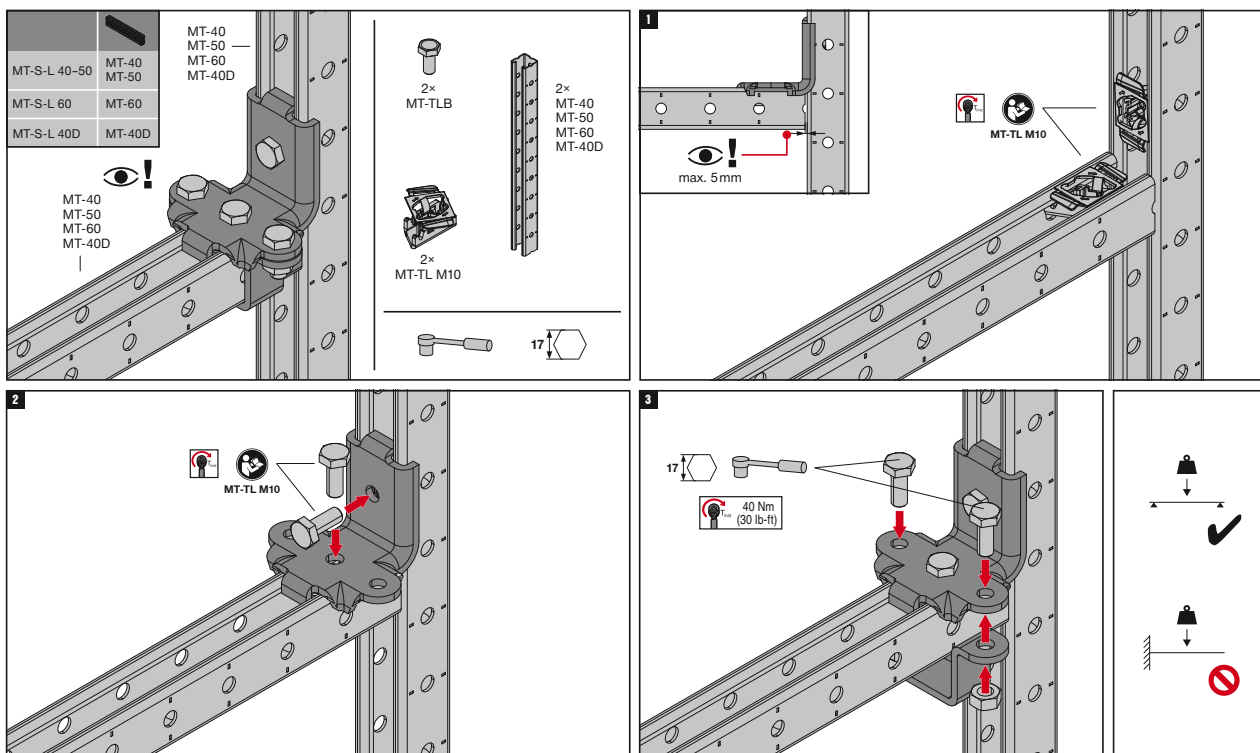

The latest IFU (Instruction for Use) is available on Hilti Online. Please check for any revisions before installing the product.

MT-S-H1 Seismic Brace Base

Operation instruction

MT-S-H1 M10/ MT-S-H1 M12

MT-S-H1 M10 OC/ MT-S-H1 M12 OC

1

2294625-03.2022

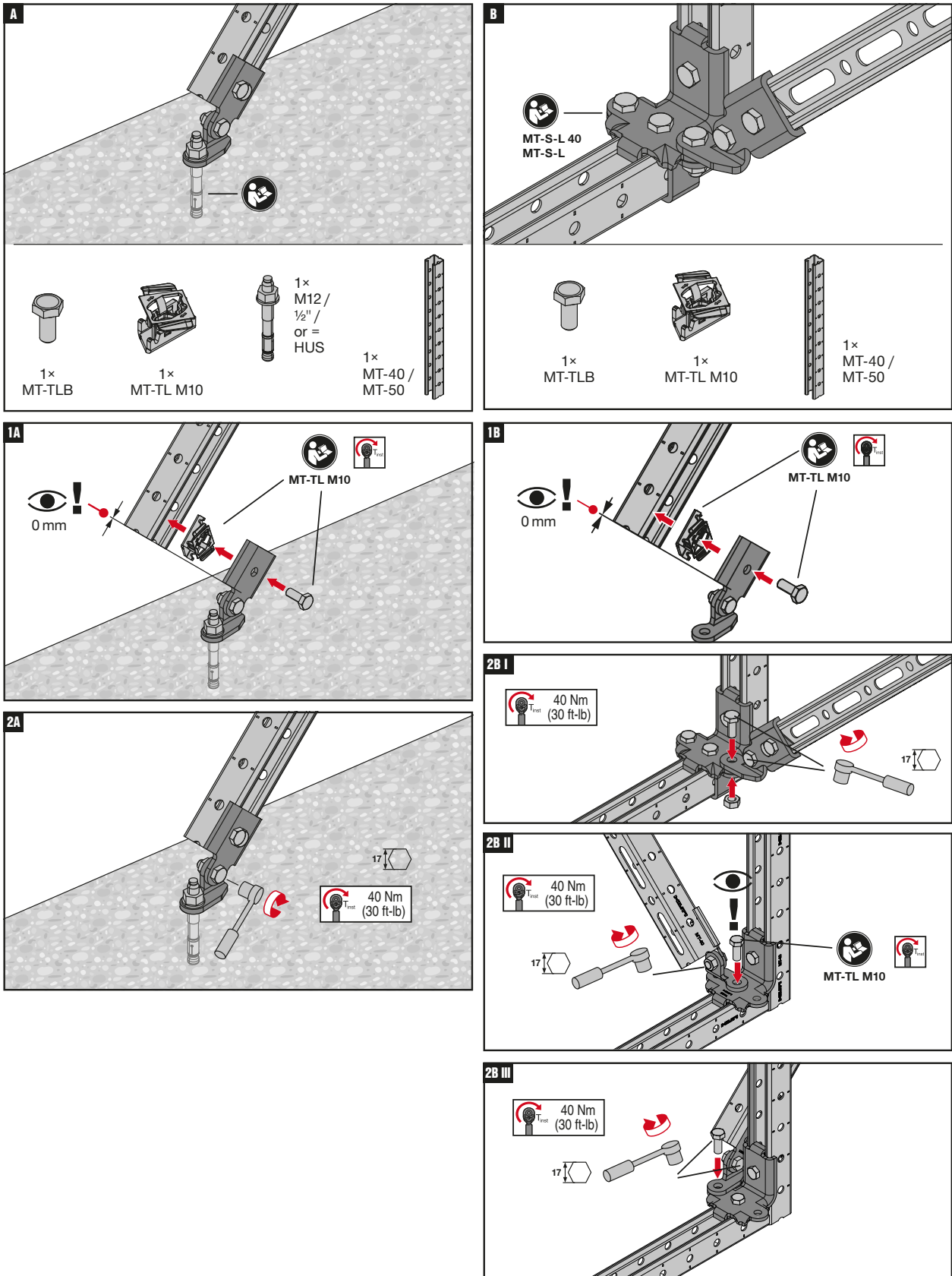

The latest IFU (Instruction for Use) is available on Hilti Online. Please check for any revisions before installing the product.

MT-S-H2 Seismic Brace Base

Operation instruction

MT-S-H2 M10/ MT-S-H2 M12

MT-S-H2 M10 OC/ MT-S-H2 M12 OC

9

2300064-10.2020

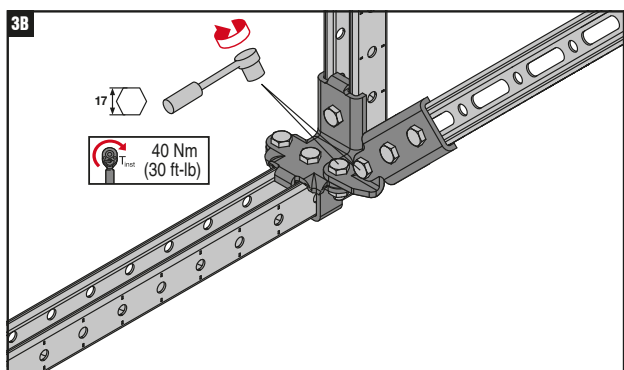
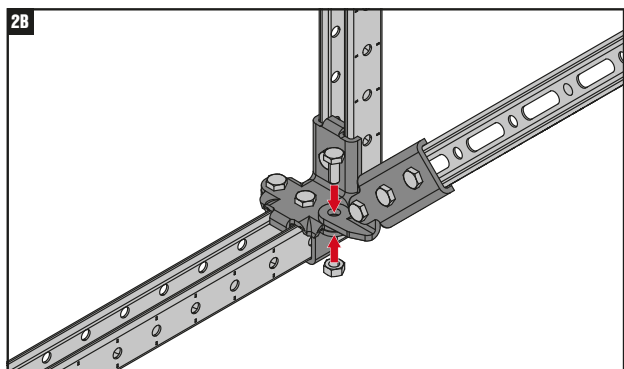
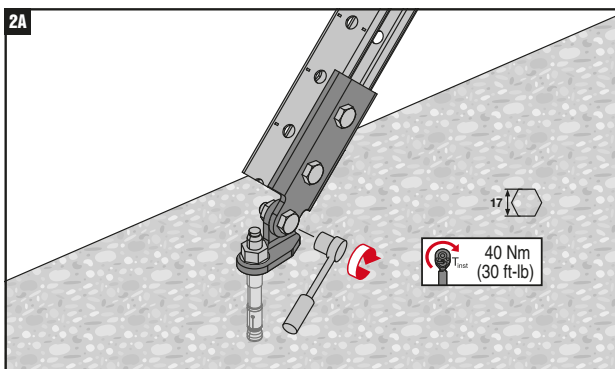
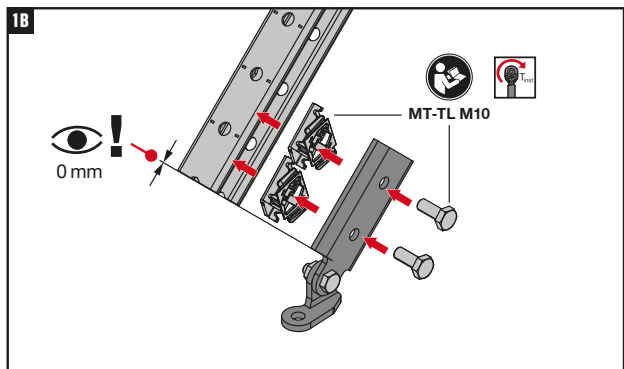
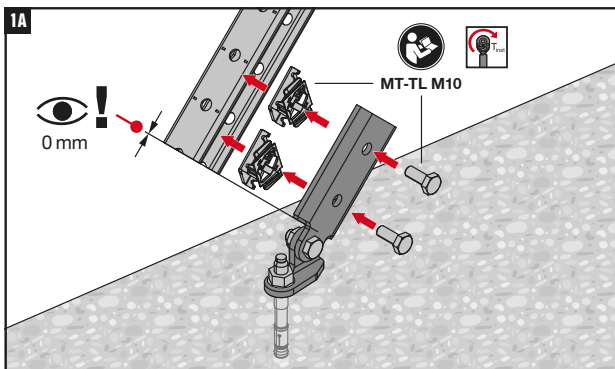
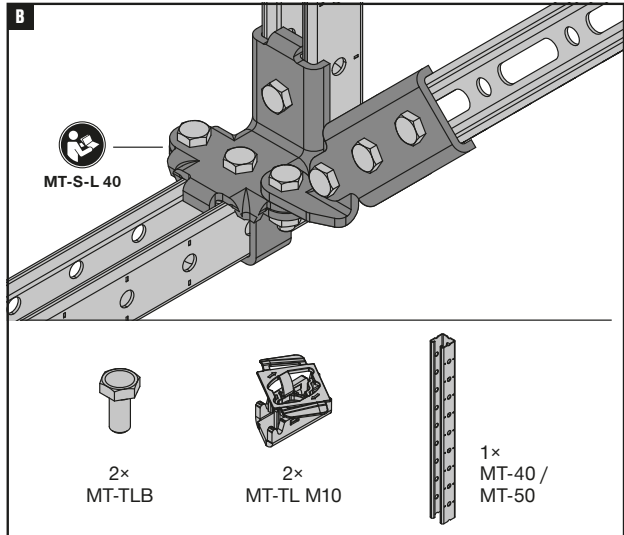
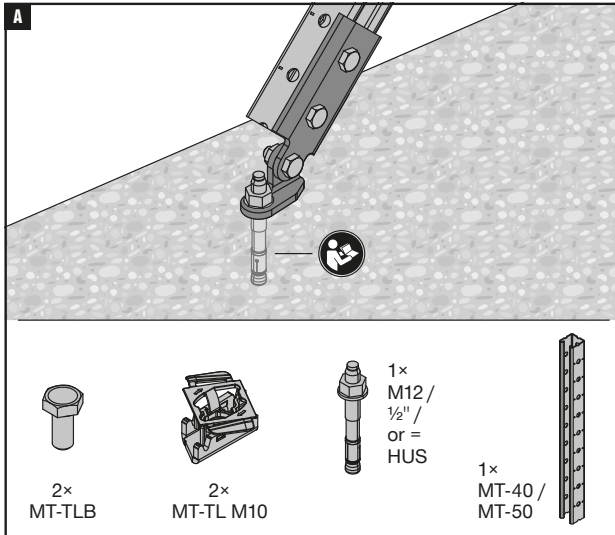

The latest IFU (Instruction for Use) is available on Hilti Online. Please check for any revisions before installing the product.

MT-S-A Seismic hinge

Galvanized seismic hinge for use as a bracing component

9

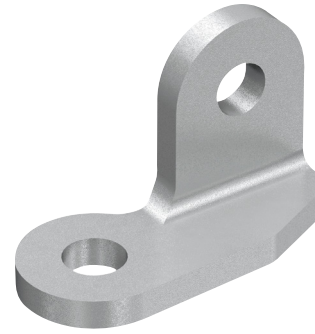
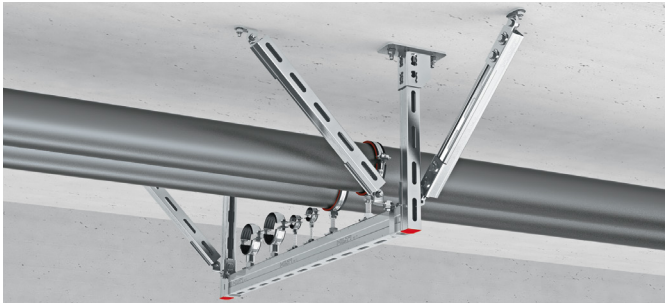

Applications

- Installing pipes, cable trays and air duct supports in seismic-relevant areas

Technical Data

Material composition	S355 MC - DIN EN 10149-2
Surface finish	Indoor Coated - Electro galvanized

Advantages

- High load capacity – engineered for optimal transfer of seismic loads
- Easily combinable with other Hilti seismic components

MT-S-A Seismic hinge

Order Designation	Technical Data	Diameter - D	Sales pack quantity	Item number	
MT-S-A-8	Dry indoor conditions (C1) Indoor with temporary condensation (C2)	9,40 mm	10 pc	2083721	
MT-S-A-10		11,55 mm	10 pc	2083722	
MT-S-A-12		13,65 mm	10 pc	2083723	
MT-S-A-16		16,30 mm	10 pc	2083724	

MT-S-AP Seismic rod hinge

Galvanized threaded rod hinge for Seismic Bracing of MEP support structures

9

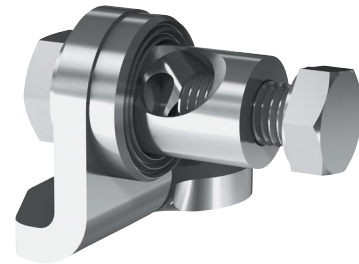
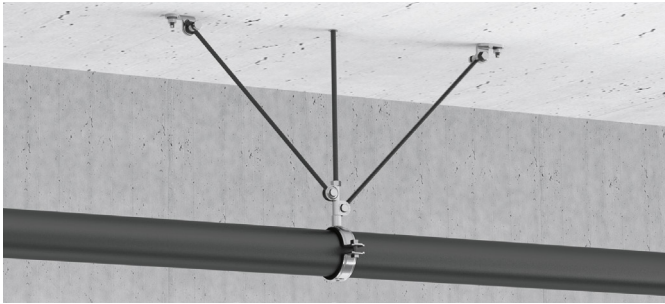

Applications

- Installing pipes, cable trays and air duct supports in seismic-relevant areas
- Fastening threaded rod Seismic Bracing to concrete or connecting to MQS-W seismic angles
- Recommended for use in dry, interior environments

Technical Data

Material composition	Baseplate: S355MC - DIN EN 10149-2, Pin: 11SMn30+C - DIN EN 10277-3, Threaded washer: 11SMn30+C - DIN EN 10277-3, Hexagon screws: Steel grade 8.8, Washer: Galvanized steel
Surface finish	Indoor Coated - Electro galvanized

Advantages

- Rapid installation – helps to save time on-site thanks to single-anchor fastening: all you need is the single pre-assembled screw and no additional nuts
- High load capacity – designed for optimal seismic load transfer to the support
- Versatile – load range suitable for a wide range of light- and medium-duty MEP installations
- Engineering support available – contact your local Hilti team for project-specific advice
- Bracing pre-assembly possible – providing additional productivity in seismic support installation

MT-S-AP Seismic rod hinge

Order Designation	Technical Data	Diameter - D	Sales pack quantity	Item number	
MT-S-AP-8	Dry indoor conditions (C1) Indoor with temporary condensation (C2)	9,40 mm	10 pc	2330874	
MT-S-AP-10		11,55 mm	10 pc	2330875	
MT-S-AP-12		13,65 mm	10 pc	2330876	

MT-S-HR Seismic hinge

Galvanized seismic hinge for use as a bracing component

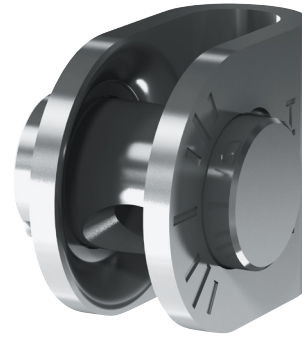
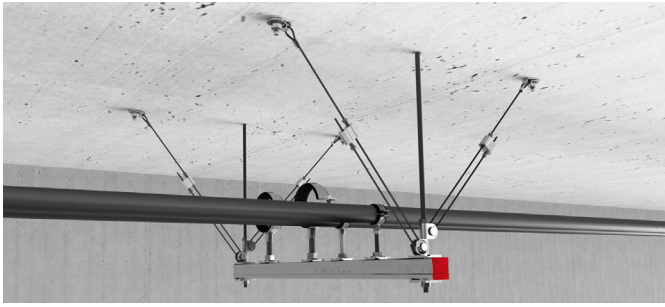

Applications

- Installing pipes, cable trays and air duct supports in seismic-relevant areas
- Connecting threaded rod and wire Seismic Bracing to MEP support structures, such as Trapeze and suspended pipe rings
- Recommended for use in dry, interior environments

Advantages

- Retrofittable and adjustable – two-component design can more easily be post-installed to existing pipe/cable supports, with angle markings to make it easier to fix the rod at 45°
- Versatile – load range suitable for a wide range of light- and medium-duty MEP installations
- Engineering support available – contact your local Hilti team for project-specific advice

Technical Data

Material composition	Connector: S275JR - EN 10025-2, Pin: 11SMnPb37+C - DIN EN 10277-3
Surface finish	Indoor Coated - Electro galvanized

MT-S-HR Seismic hinge

Order Designation	Technical Data	Diameter - D	Sales pack quantity	Item number	
MT-S-HR-8	Dry indoor conditions (C1) Indoor with temporary condensation (C2)	8 mm	10 pc	2330877	
MT-S-HR-10		10 mm	10 pc	2330878	

MT-S-CH Seismic rod hinge

Galvanized pre-assembled threaded rod brace Connector with increased load capacity for mounting to Base Material

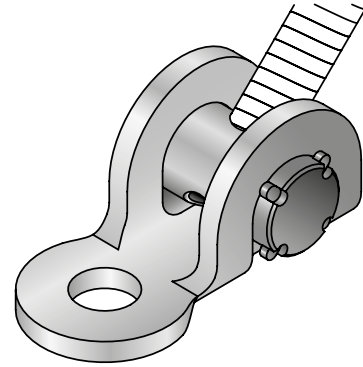
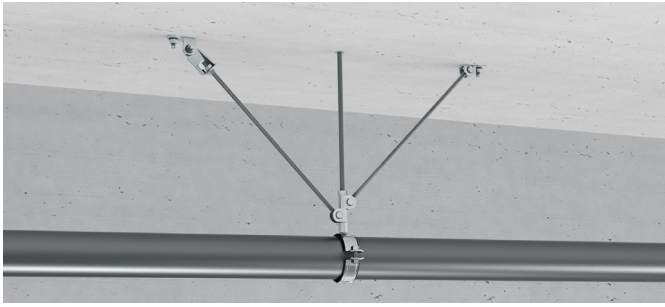

Applications

- Installing pipes, cable trays and air duct supports in seismic-relevant areas
- Assembling Seismic Bracing using threaded rods in a wide range of seismic Applications

Advantages

- Easier and quicker to mount to M10 threaded rod
- Maximum installation flexibility due to adjustable angle
- Higher load capacity – engineered for optimal transfer of seismic loads

Technical Data

Material composition	Connector: S275JR - DIN EN 10025, Pin: 11SMnPb37+C
Surface finish	Indoor Coated - Electro galvanized

MT-S-CH Seismic rod hinge

Order Designation	Technical Data	Sales pack quantity	Item number	
MT-S-CH-10	Dry indoor conditions (C1) Indoor with temporary condensation (C2)	10 pc	2083741	

MT-S-AP Seismic rod hinge

9

Operation instruction

MT-S-AP-8 / MT-S-AP-10 / MT-S-AP-12

2332868-02.2022

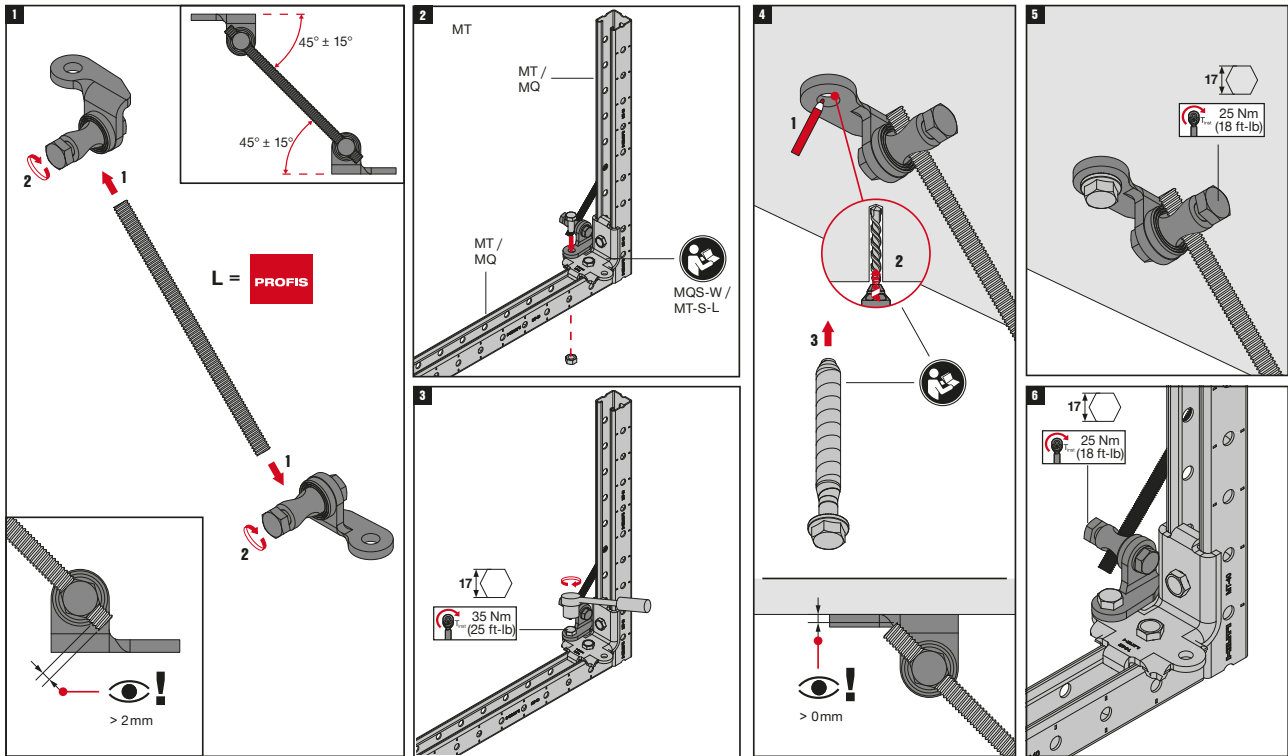

The latest IFU (Instruction for Use) is available on Hilti Online. Please check for any revisions before installing the product.

MT-S-HR Seismic hinge

Operation instruction

MT-S-HR-8 / MT-S-HR-10

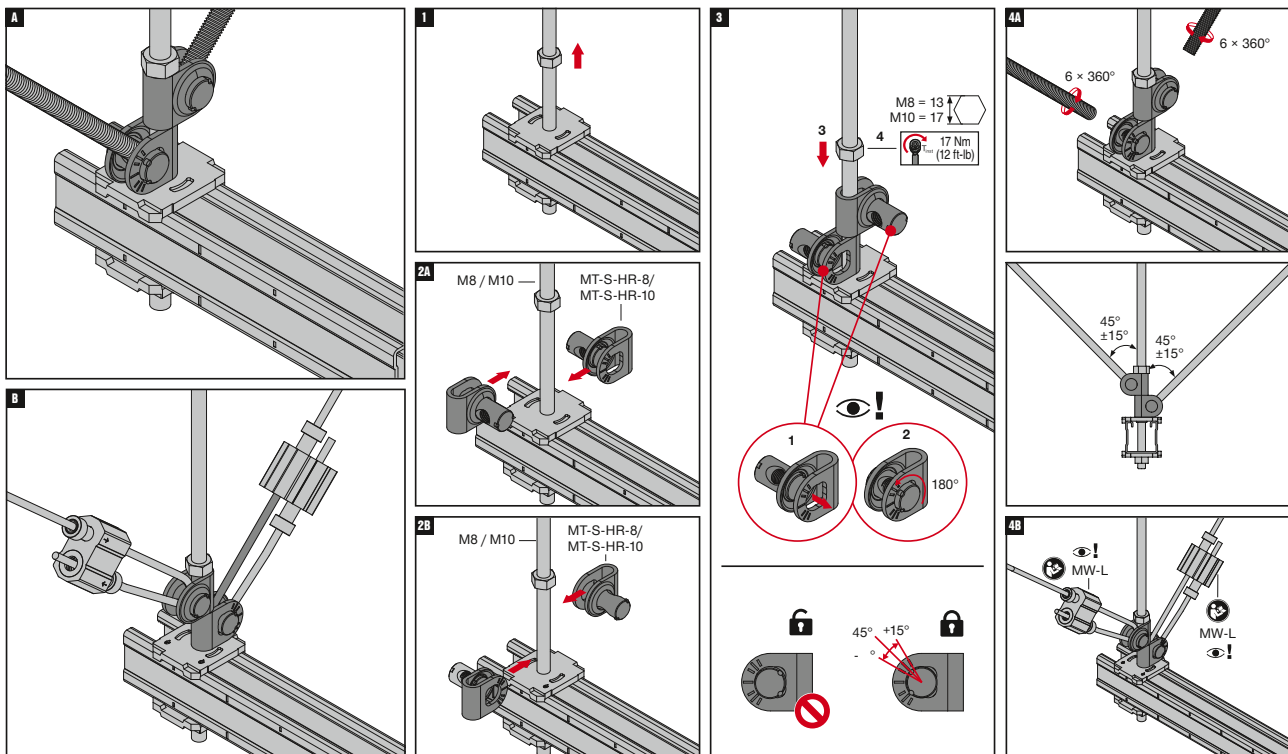

The latest IFU (Instruction for Use) is available on Hilti Online. Please check for any revisions before installing the product.

MT-S-CH Seismic rod hinge

Operation instruction MT-S-CH-10

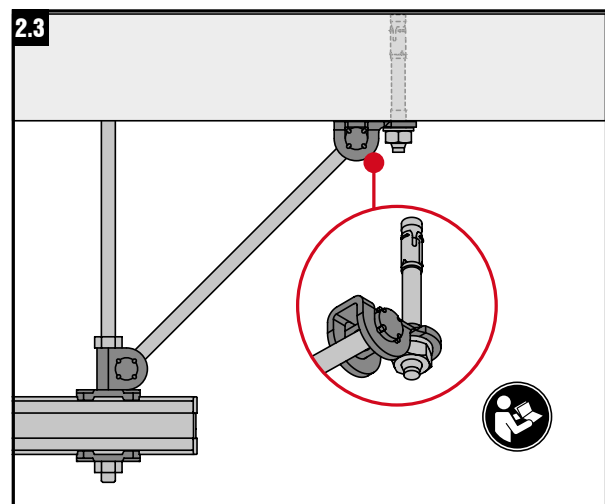
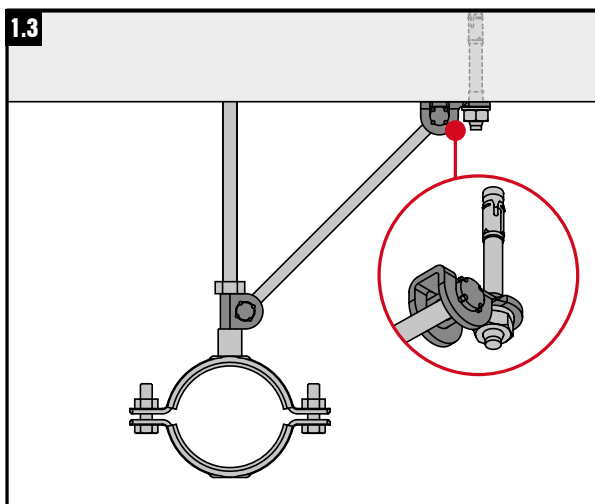
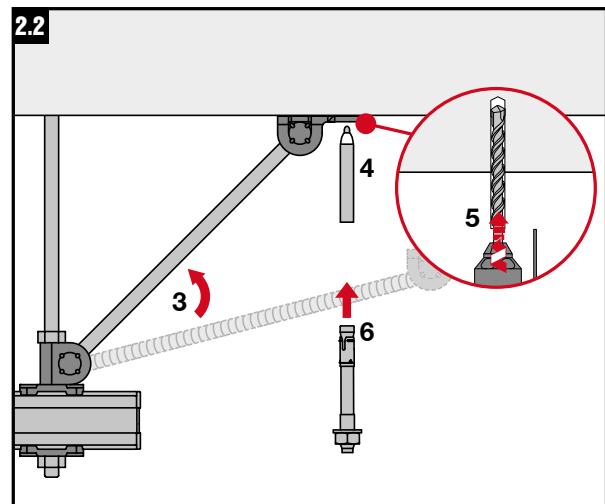
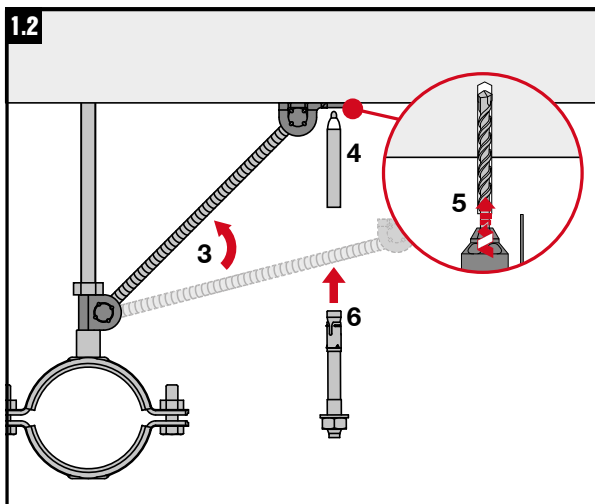
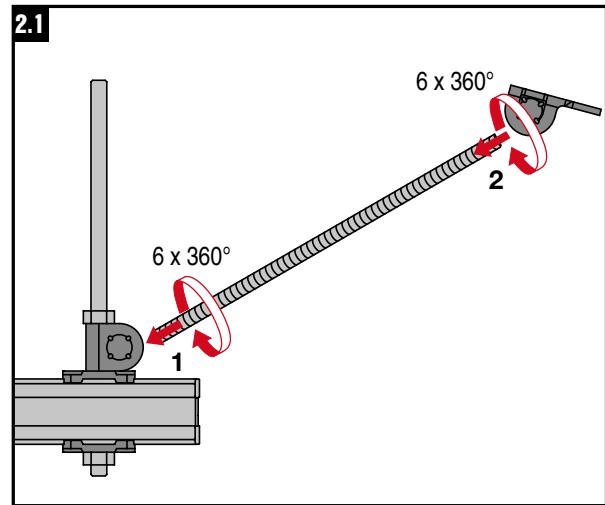
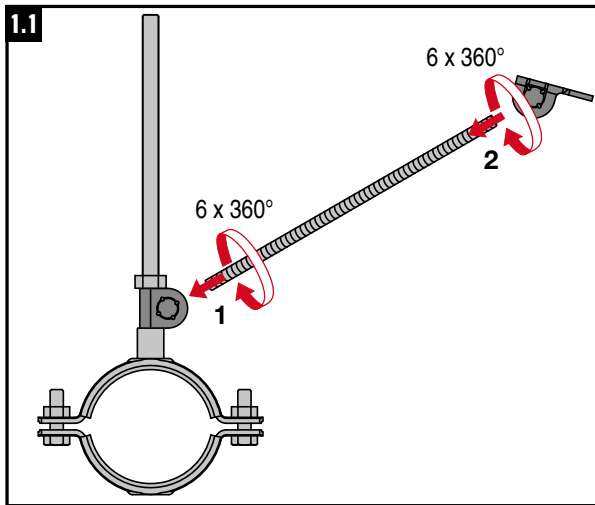

The latest IFU (Instruction for Use) is available on Hilti Online. Please check for any revisions before installing the product.

MT-S-SP Seismic sprinkler pipe clamps

MT-S-SP Pre-assembled seismic sprinkler pipe clamps



Applications

- Seismic approved (FM) bracing of fire sprinkler pipes
- Attaching pipes for longitudinal or transversal brace assembly
- for use in combination with MT modular support systems and MT-S-SP C seismic Connectors
- Suitable for use in dry indoor environments

Technical Data

Material composition	Pipe ring S275JR - EN 10025, Hinge Connector S355MC - DIN EN 10149-2, Bolt Steel grade 8.8, Nut Steel grade 8
Surface finish	Indoor Coated - Electro galvanized

Advantages

- Faster installations – pre-assembled MT Fast-Lock mechanisms and shear-off bolt heads enable our fastest method for assembling Seismic Bracing for fire sprinkler pipes
- Simpler installations and inspection – shear-off bolt head-design allows you to quickly install and confirm correct installations at a glance
- Higher load capacity – engineered to optimize the transfer of seismic loads, helping reduce the total cost of installation
- Versatile – universal seismic sprinkler pipe clamps can be used in both longitudinal and transversal bracing applications, and help simplify stock management
- Part of the Hilti MT System – an economical, all-in-one solution for virtually all modular MEP support structures
- Engineering and calculation service available – your local Hilti Engineers can provide advice and calculation services on more complex projects

MT-S-SP Seismic sprinkler pipe clamps

Order Designation	Nominal Pipe size cm, [in]	Clamping range, min mm, [inch]	Clamping range, max mm, [inch]	Weight [kg]	Technical Data	Sales pack quantity	Item number
MT-S-SP 2"	50 [2]	60 [2.4]	65 [2.6]	0.94	Dry indoor conditions (C1) Indoor with temporary condensation (C2)	10 pc	2388096
MT-S-SP 2 1/2"	65 [2 1/2]	73 [2.9]	78 [3.1]	1.02		10 pc	2388097
MT-S-SP 3"	80 [3]	88 [3.5]	93 [3.7]	1.10		10 pc	2388098
MT-S-SP 4"	100 [4]	108 [4.3]	116 [4.6]	1.22		10 pc	2388099
MT-S-SP 5"	125 [5]	134 [5.3]	142 [5.6]	1.36		10 pc	2388220
MT-S-SP 6"	150 [6]	162 [6.4]	170 [6.7]	1.98		5 pc	2388221
MT-S-SP 8"	200 [8]	213 [8.4]	221 [8.7]	2.35		5 pc	2388222
MT-S-SP 10"	250 [10]	267 [11]	275 [11]	2.76		5 pc	2388223
MT-S-SP 12"	300 [12]	318 [13]	326 [13]	3.15		5 pc	2388224

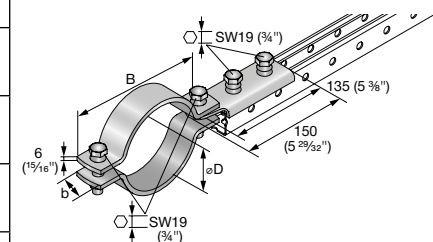
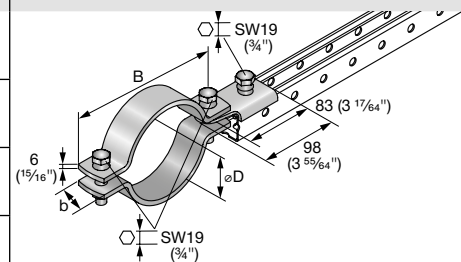

MT-S-SP C Seismic Connector

FM-approved MT seismic sprinkler Connector with pre-assembled Fast-Lock mechanisms

9



Applications

- Seismic approved (FM) bracing of fire sprinkler pipes
- Attaching pipes for longitudinal or transversal brace assembly
- for use in combination with MT modular support systems and MT-S-SP C seismic Connectors
- Suitable for use in dry indoor environments

Technical Data

Material composition	Q355 or better steel Bolt Steel grade 8.8
Surface finish	Indoor Coated - Electro galvanized

Advantages

- Faster installations – pre-assembled MT Fast-Lock mechanisms and shear-off bolt heads enable our fastest method for assembling Seismic Bracing for fire sprinkler pipes
- Simpler installations and inspection – shear-off bolt head-design allows you to quickly install and confirm correct installations at a glance
- Higher load capacity – engineered to optimize the transfer of seismic loads, helping reduce the total cost of installation
- Easy and flexible mounting – once positioned, the seismic Connector can be rotated 360° around the anchor plate and offers an adjustable bracing angle
- All-in-one Connector – universal seismic Connector can be used in both longitudinal and transversal bracing applications, and helps simplify stock management
- Part of the Hilti MT System – an economical, all-in-one solution for virtually all modular MEP support structures
- Engineering and calculation service available – your local-Hilti Engineers can provide advice and calculation services on more complex projects

MT-S-SP C Seismic Connector

Order Designation	Weight [kg]	Technical Data	Sales pack quantity	Item number	
MT-S-SP C	0.64	Dry indoor conditions (C1) Indoor with temporary condensation (C2)	15 pc	2388225	<p>Technical drawing showing dimensions (mm and inches):</p> <ul style="list-style-type: none"> 143 (5 5/8") 125 (4 59/64") 4 (5/32") SW19 (3/4") 58 (9/32") 52 (2 3/64") 38 (1 1/2") 5 (13/64") 13.1 (33/64")

MT-S-SP Seismic sprinkler pipe clamps

Operation instruction

9

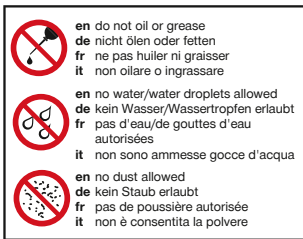
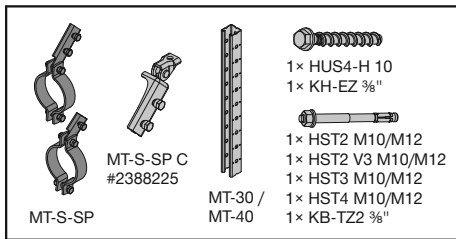

Item Name	DN (mm)	Item Number	
MT-S-SP 2"	DN 50	#2388096	
MT-S-SP 2 1/2"	DN 65	#2388097	
MT-S-SP 3"	DN 80	#2388098	
MT-S-SP 4"	DN 100	#2388099	
MT-S-SP 5"	DN 125	#2388220	
MT-S-SP 6"	DN 150	#2388221	
MT-S-SP 8"	DN 200	#2388222	
MT-S-SP 10"	DN 250	#2388223	
MT-S-SP 12"	DN 300	#2388224	

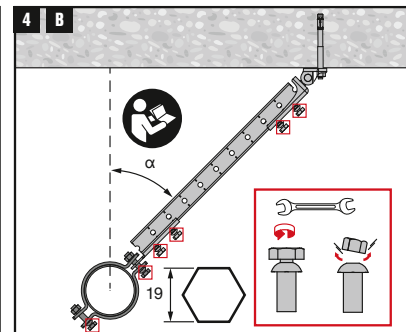
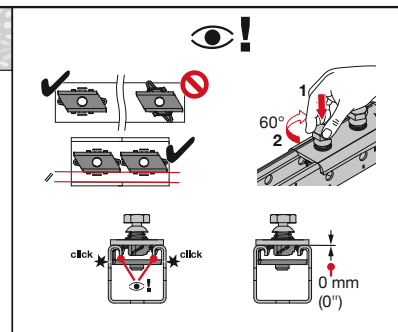
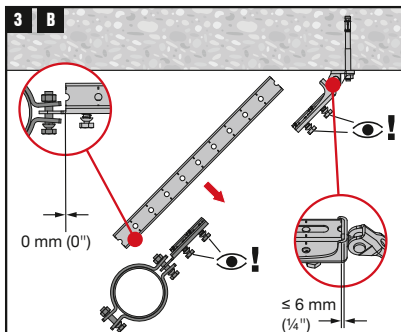
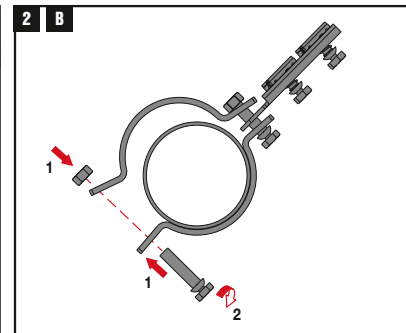
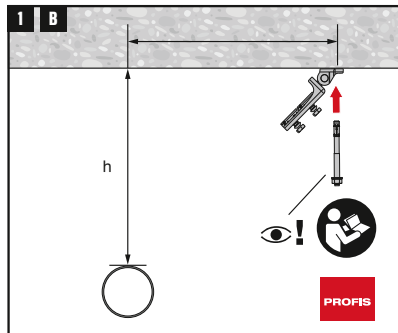
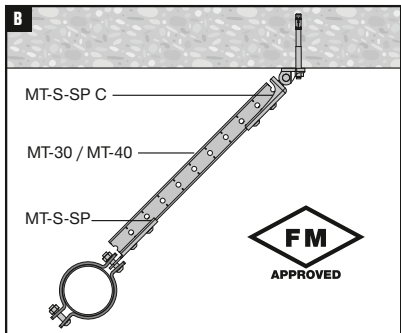
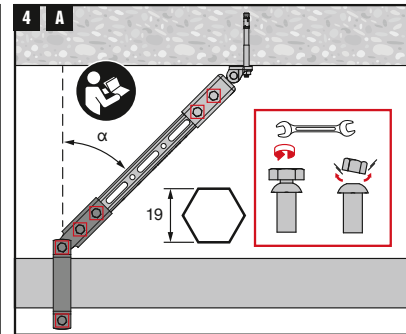
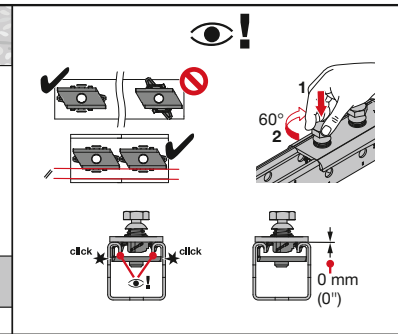
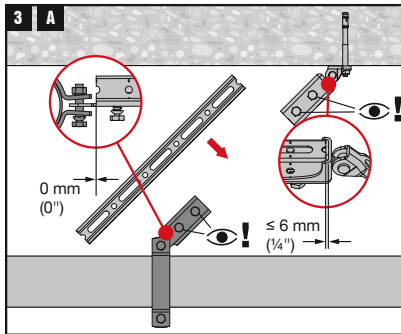
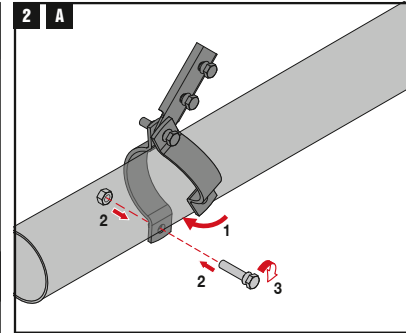
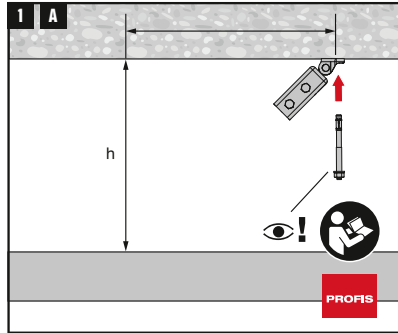
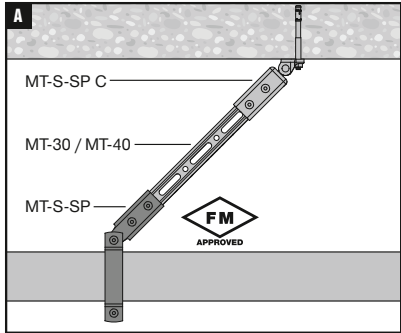

The latest IFU (Instruction for Use) is available on Hilti Online. Please check for any revisions before installing the product.

MT-S-SP C Seismic Connector

Operation instruction

9

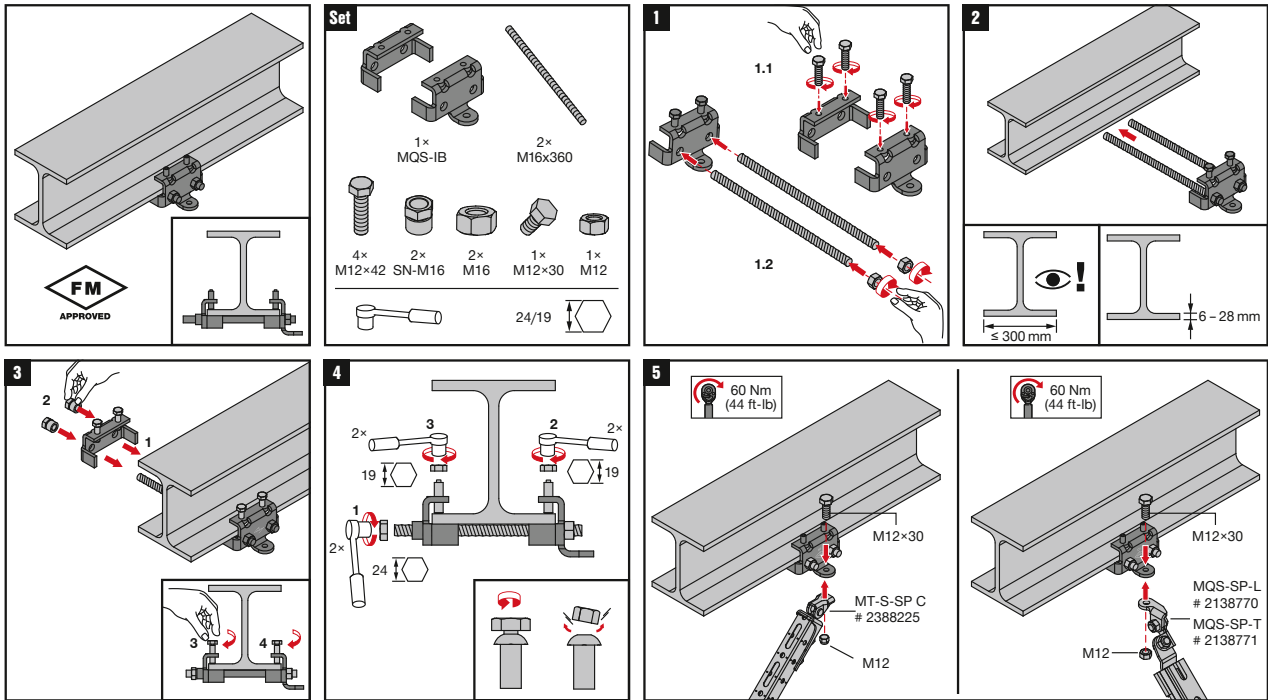

The latest IFU (Instruction for Use) is available on Hilti Online. Please check for any revisions before installing the product.

10. MT Elevator Divider Beam portfolio

MT-EDB OC Elevator Connector

Heavy-duty adjustable baseplate for connecting an MT girder horizontally between two parallel walls

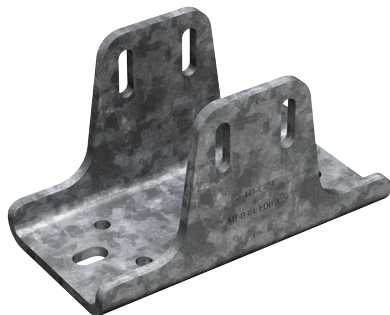

Applications

- Constructing MT-80, MT-90 and MT-100 divider beams/rail guards in Elevator shafts
- Fastening long-span, wall-to-wall supports for medium/heavy-load pipes using MT-80, MT-90 or MT-100 girders
- Supports for medium/heavy-load air ducts and cabling between two adjacent walls

Technical Data

Material composition	Q355 or better steel
Surface finish	Hot-dip galvanized - for outdoor use

Advantages

- Full adjustability – up to 40 mm along the length of the girder for higher cutting tolerance on the jobsite
- No welding required – for faster, more efficient installation
- Leaner inventory – this new solution uses fewer and lighter components than previous Hilti divider beam Connectors, so you can do more with the same parts
- Corrosion resistance – hot-dip galvanized to help protect against moisture and chemical corrosion
- Part of the Hilti MT system – an economical, all-in-one solution for virtually all modular MEP support structures
- Full adjustability – up to 1-5/8" along the length of the girder for higher cutting tolerance on the jobsite

MT-EDB OC Elevator Connector

Order Designation	Technical Data	Sales pack quantity	Item number	
MT-B-GL EDB OC set	Outdoor, low to moderate pollution (C3 / C4 - low)	2	2353802	
MT-B-GL EDB A OC		4	2353803	
MT-B-GS EDB OC set		3	2353804	
MT-B-GS EDB A OC		6	2353805	
MT-B-EDB A OC		10	2353810	

MT-EDB Elevator Connector

Heavy-duty adjustable baseplate for connecting an MT girder horizontally between two parallel walls

10



Applications

- Constructing MT-80, MT-90 and MT-100 divider beams/rail guards in Elevator shafts
- Fastening long-span, wall-to-wall supports for medium/heavy-load pipes using MT-80, MT-90 or MT-100 girders
- Supports for medium/heavy-load air ducts and cabling between two adjacent walls

Advantages

- Full adjustability – up to 40 mm along the length of the girder for higher cutting tolerance on the jobsite
- No welding required – for faster, more efficient installation
- Leaner inventory – this new solution uses fewer and lighter components than previous Hilti divider beam Connectors, so you can do more with the same parts
- Corrosion resistance – hot-dip galvanized to help protect against moisture and chemical corrosion
- Part of the Hilti MT system – an economical, all-in-one solution for virtually all modular MEP support structures
- Full adjustability – up to 1-5/8” along the length of the girder for higher cutting tolerance on the jobsite

Technical Data

Material composition	Q355 or better steel
Surface finish	Pre-galvanized - for dry indoor use only

MT-EDB Elevator Connector

Order Designation	Technical Data	Sales pack quantity	Item number	
MT-BRL-EDB M12	Dry indoor conditions (C1) Indoor with temporary condensation (C2)	10	2353806	
MT-BRL-EDB M16		10	2353807	
MT-BRS-EDB M12		6	2353808	
MT-BRS-EDB M16		6	2353809	

Technical Data Elevator Divider Beams

Item image	Load drawing	Order Designation	F _x	F _y	F _z
		MT-B-GL EDB	36,51 kN	7,31 kN	18,09 kN
		MT-B-GL EDB A	2,69 kN	4,97 kN	18,09 kN
		MT-B-GS EDB	42,29 kN	3,87 kN	15,53 kN
		MT-B-GS EDB A	1,35 kN	3,75 kN	15,53 kN
		MT-BRL EDB M12	15,05 kN	12,04 kN	2,67 kN
		MT-BRL EDB M16	15,05 kN	12,04 kN	2,67 kN
		MT-BRS EDB M12	14,00 kN	10,13 kN	2,67 kN
		MT-BRS EDB M16	14,00 kN	10,13 kN	2,67 kN

MT-B-GL EDB OC
Operation instruction

10

630000001.2026.0

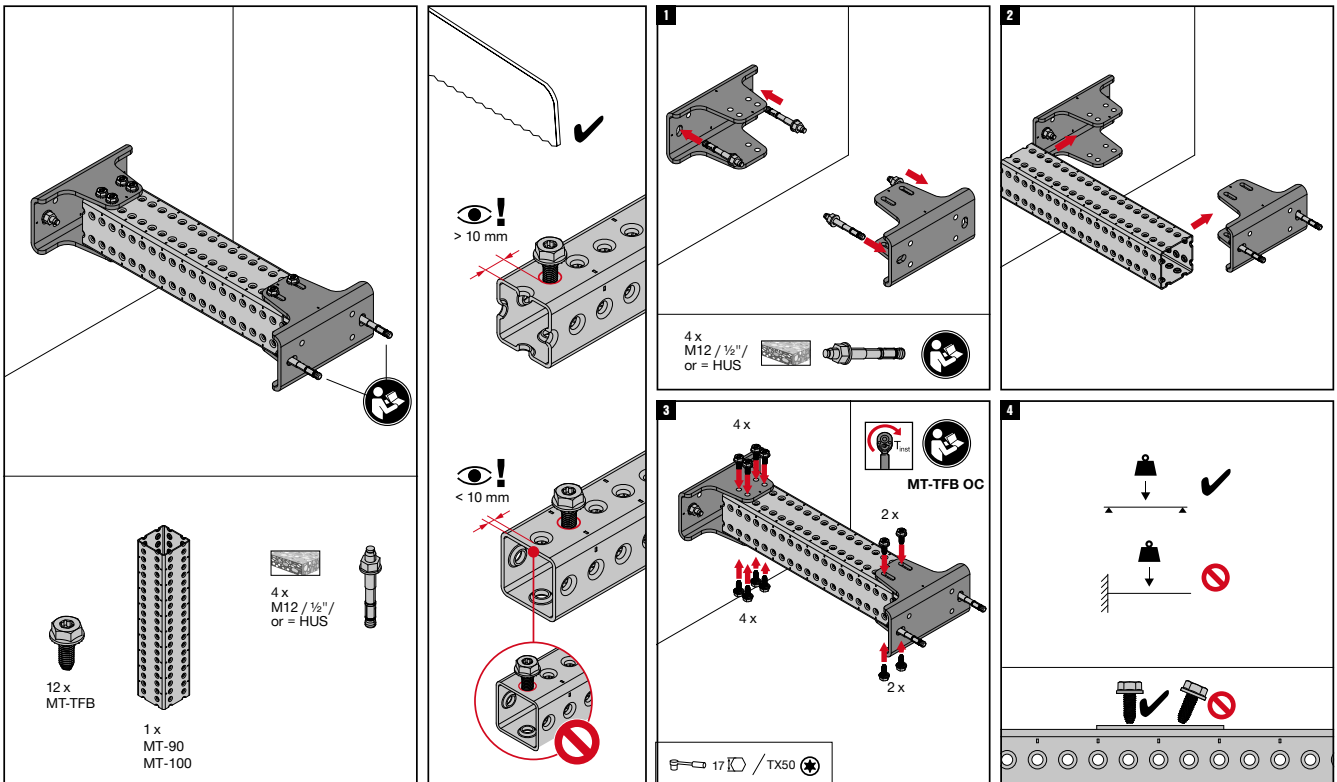

The latest IFU (Instruction for Use) is available on Hilti Online. Please check for any revisions before installing the product.

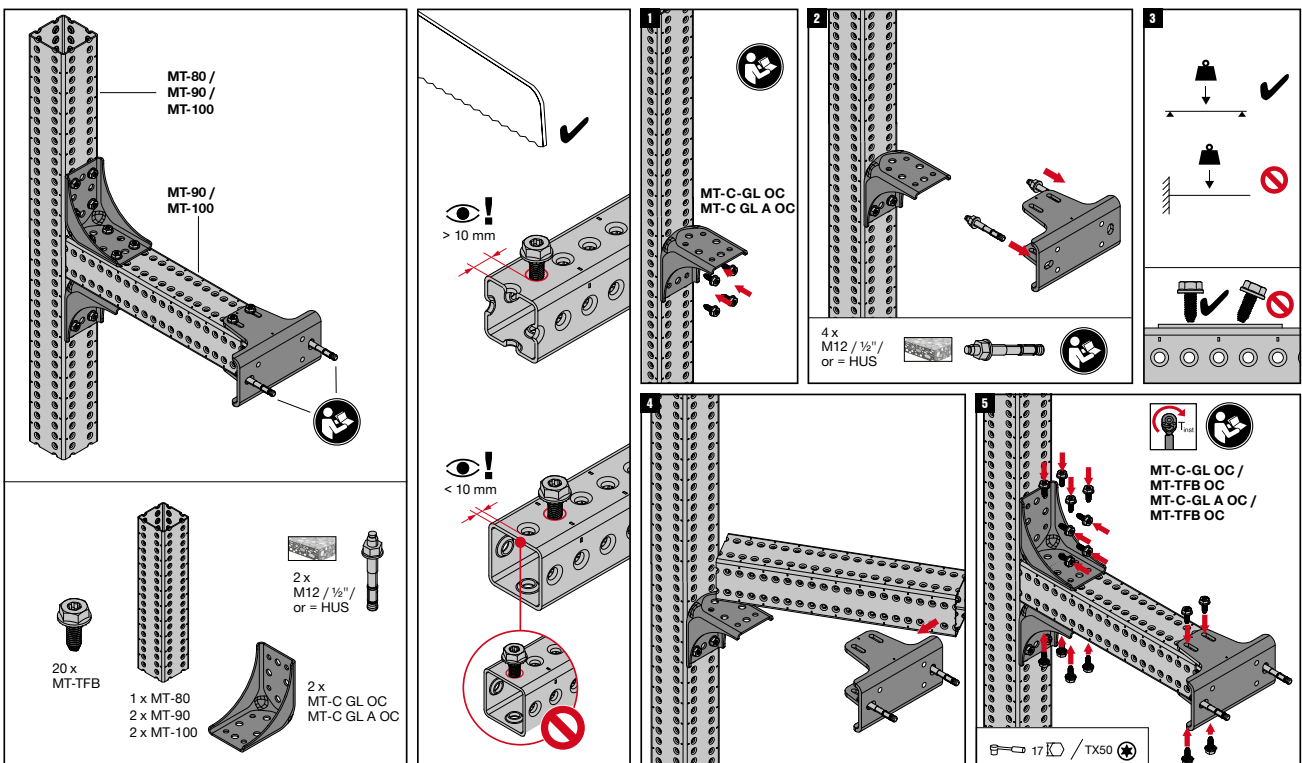

The latest IFU (Instruction for Use) is available on Hilti Online. Please check for any revisions before installing the product.

MT-B-GS EDB OC
Operation instruction

63000011-05-0006

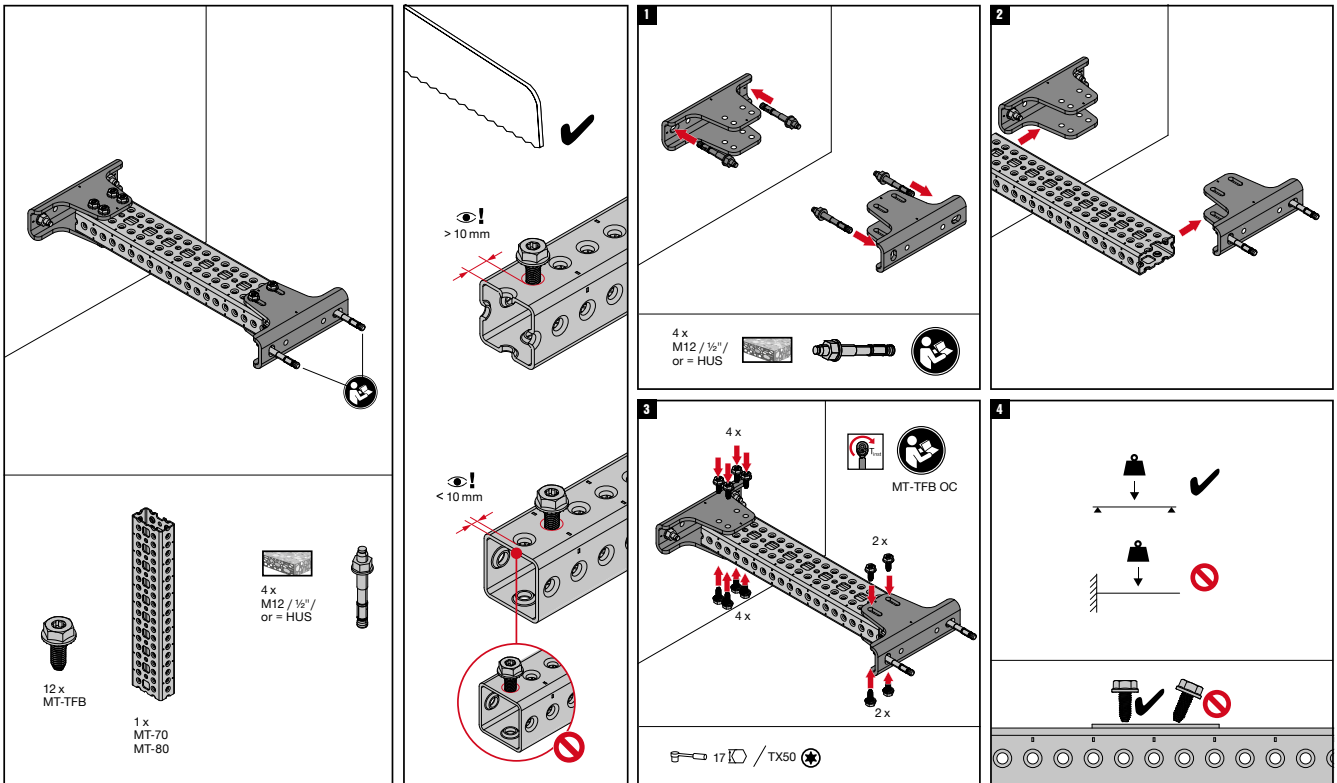

The latest IFU (Instruction for Use) is available on Hilti Online. Please check for any revisions before installing the product.

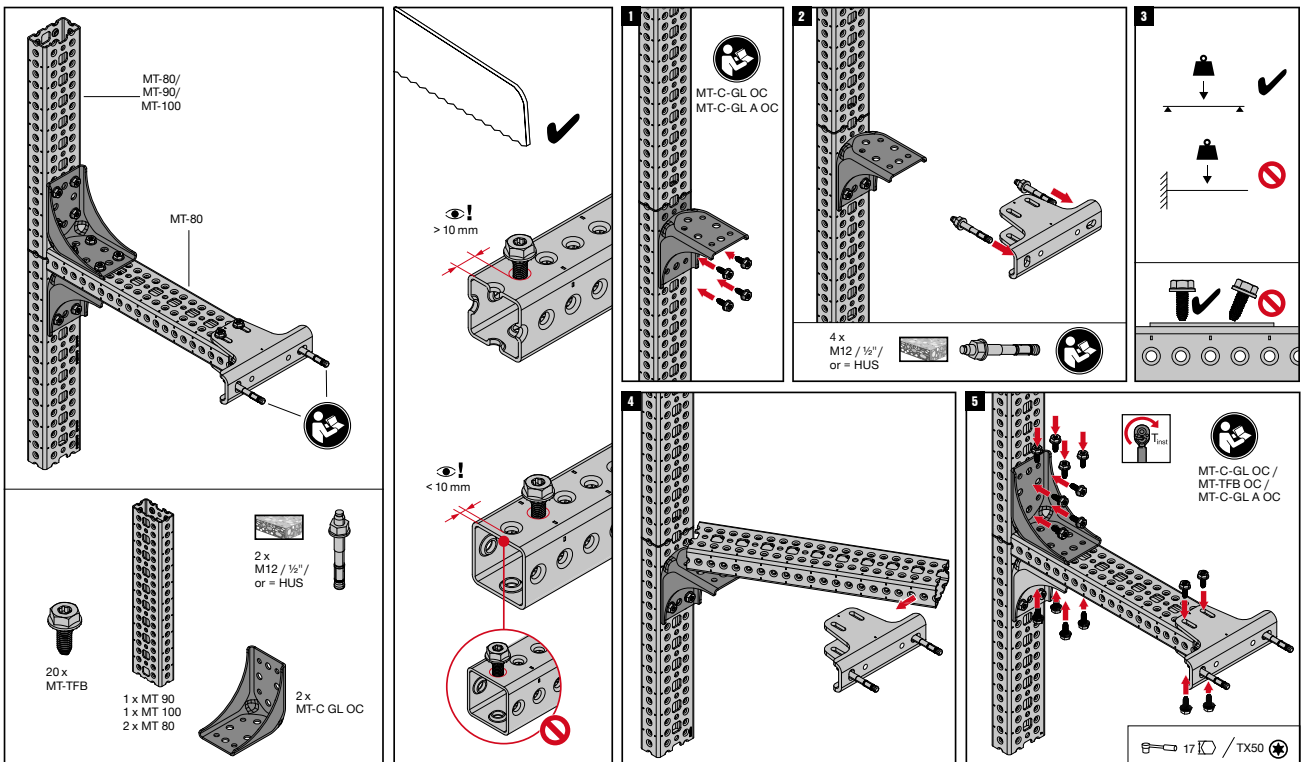

The latest IFU (Instruction for Use) is available on Hilti Online. Please check for any revisions before installing the product.

MT-BRL EDB

Operation instruction

2359999-08.2022

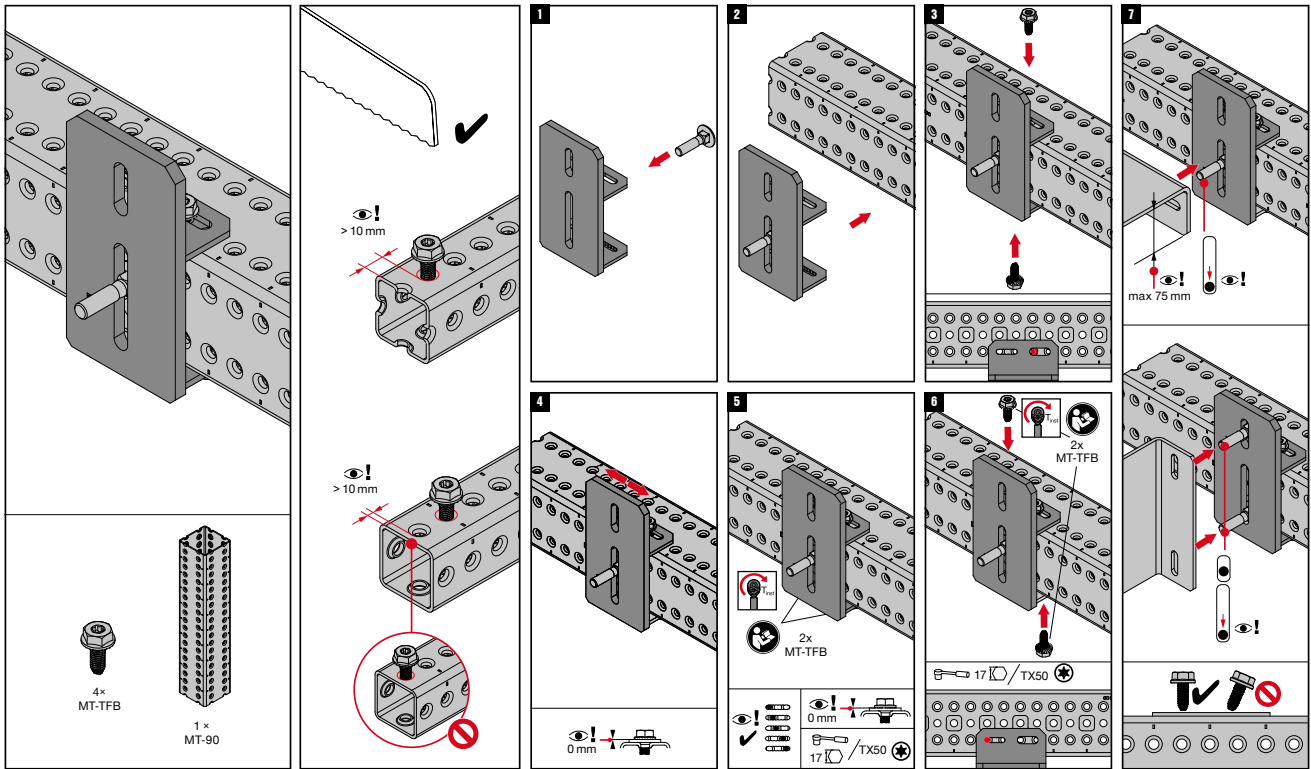

The latest IFU (Instruction for Use) is available on Hilti Online. Please check for any revisions before installing the product.

MT-BRS EDB

Operation instruction

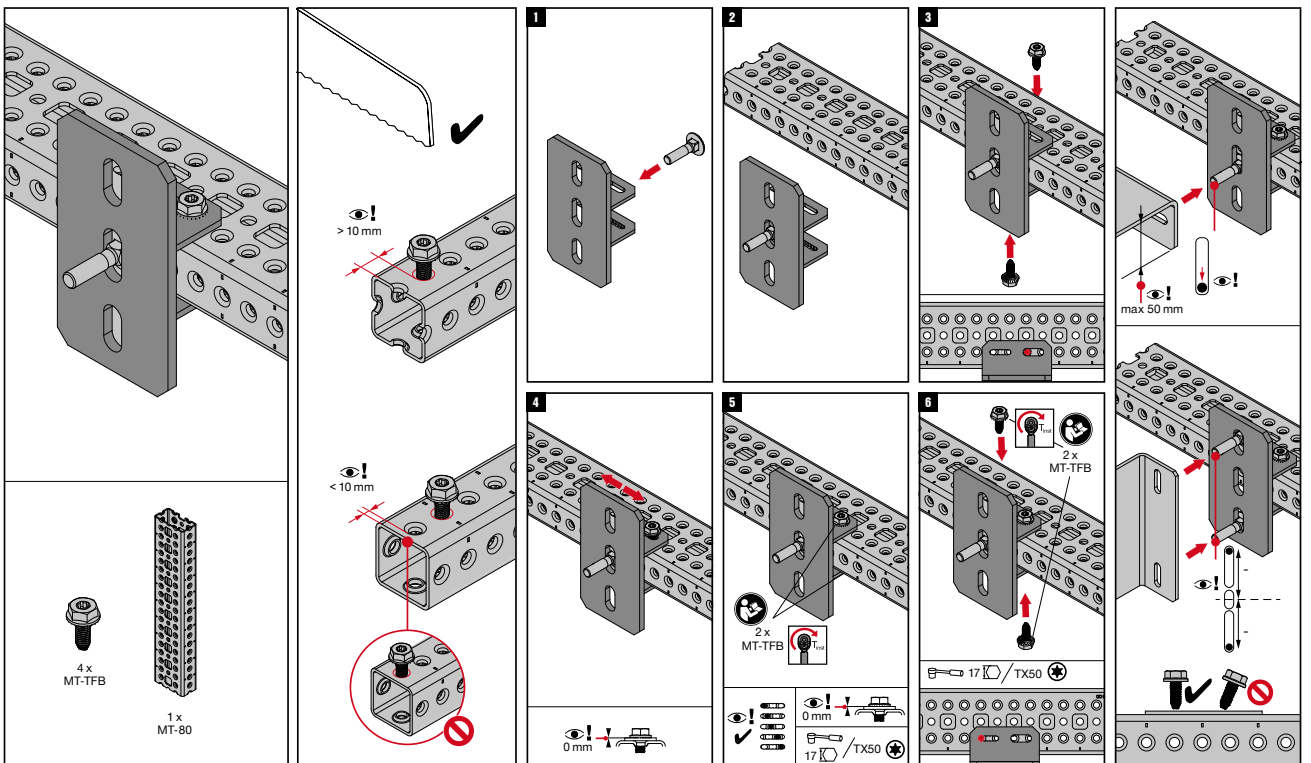

The latest IFU (Instruction for Use) is available on Hilti Online. Please check for any revisions before installing the product.

MT-B EDB A OC

Operation instruction
MT-B EDB A OC

00000000120000

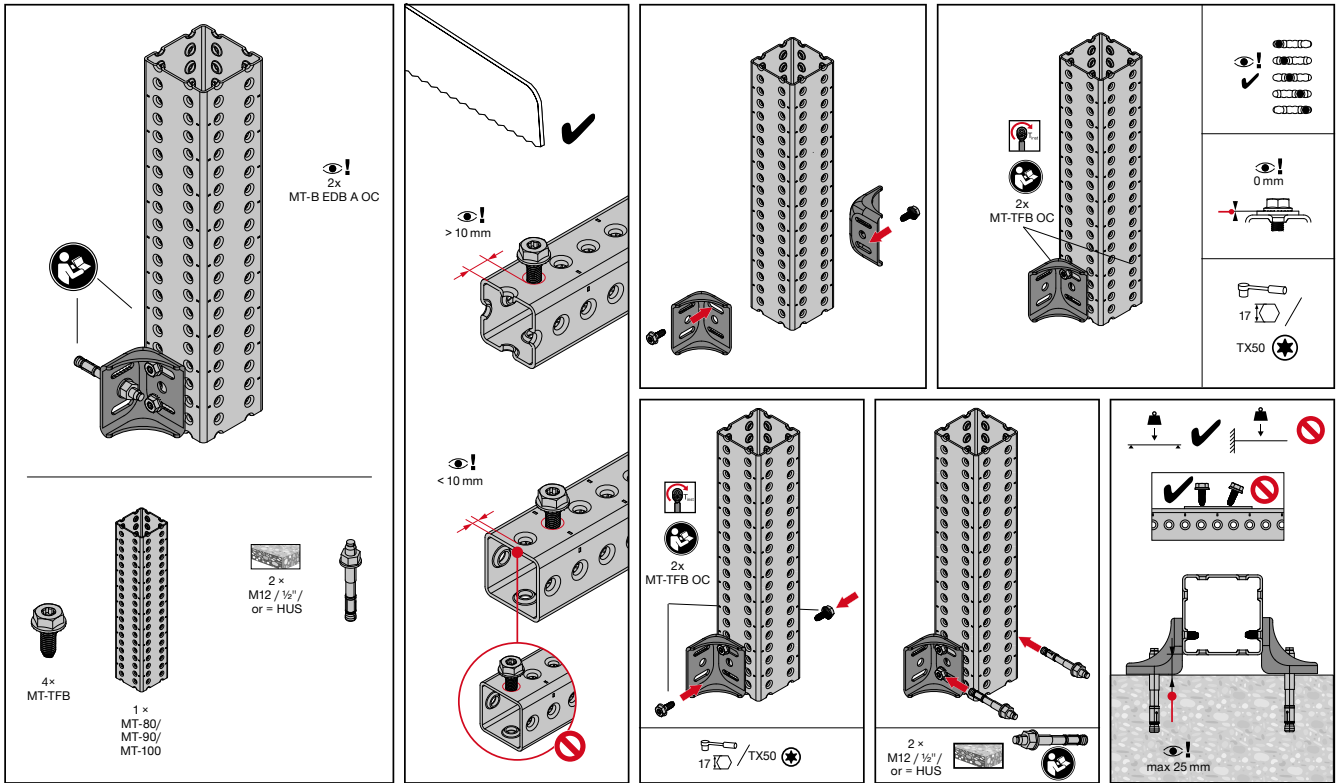

The latest IFU (Instruction for Use) is available on Hilti Online. Please check for any revisions before installing the product.



Hilti Corporation
9494 Schaan Liechtenstein
Tel.: +423-234 2111

www.facebook.com/hiltigroup
www.hilti.group